

Installation Instructions For Service Only

Express® Two-Station Lavatory System with Pushbutton Air Valve (Standard* and Juvenile Height)

*Standard Height Unit is
ADA compliant.



Table of Contents

Pre-Installation Information	2
Dimensions	3-4
Installation Instructions	5-10
Cleaning and Maintenance	11
Soap Dispenser Maintenance	12-13
Check Valve Troubleshooting	12
Assembly of Components	14-15
Metering Air Valve Maintenance	16
Metering Air Valve Troubleshooting	16-17
Vernatherm™ Thermostatic Mixing Valve	18



IMPORTANT

Read this entire installation manual to ensure proper installation.

Flush all the water supply lines before making connections.

Wall anchors used must have a minimum pull-out rating of 1,000 lbs.

File these instructions with the owner or maintenance department.



Pre-Installation Information

Pushbutton and air valve

Each sprayhead is controlled by a pushbutton air valve, enabling each user to activate a single flow of water. Air valves use 0.5 gpm for a ten-second duration, meeting the ANSI/ASHRAE/IES 90A-1980 Standard.

Barrier-free and ADA compliant: standard height mounting

The Express® Lavatory System easily accommodates *all* users. It meets ADA, ANSI and UFAS requirements for barrier-free clearances, reaches and controls. Always check local codes and ordinances for compliance.

Note: ADA does not address Juvenile Height Express® Lavatory Systems for clearances. As a result, juvenile height systems cannot be considered ADA compliant.

Supplies required for installation:

- (6) 3/8" wall anchors, bolts and washers to mount frame and bowl to wall (minimum pull-out rating of 1,000 lbs.)
- 1/2" NPT hot and cold supply piping
- 1-1/2" NPT drain piping

Express® Lavatory System Warranty

Bradley Corporation warrants to commercial and institutional purchasers only each unit free from defects in material and workmanship under normal use and service upon the following terms and conditions:

1. This warranty is limited to replacing or repairing, at our option, transportation charges prepaid by the purchaser, any Bradley unit or part thereof which our inspection shall show to have been defective within the limitations of this warranty.
2. The period during which Express® Lavatory System components are warranted is as follows:
 - Terreon® bowl and shelf warranted for five years
 - All other Express® Lavatory System components warranted for one year.
3. This warranty does not cover installation or any other labor charges and does not apply to any units which have been damaged by accident, abuse, improper installation or improper maintenance.
4. The replacement or repair of defective units as stated in this warranty shall constitute the sole remedy of the purchaser and the sole liability of Bradley Corporation under this warranty. Bradley Corporation shall not otherwise be liable under any indirect damages caused by defects in the repair or replacement thereof.
5. This warranty extends only to commercial and institutional purchaser and does not extend to any others, including consumer customers of commercial institutional purchasers.
6. This warranty is in lieu of all other warranties, expressed or implied, including any implied warranty of merchantability or fitness for a particular purpose or otherwise.

Express® Lavatory System Dimensions

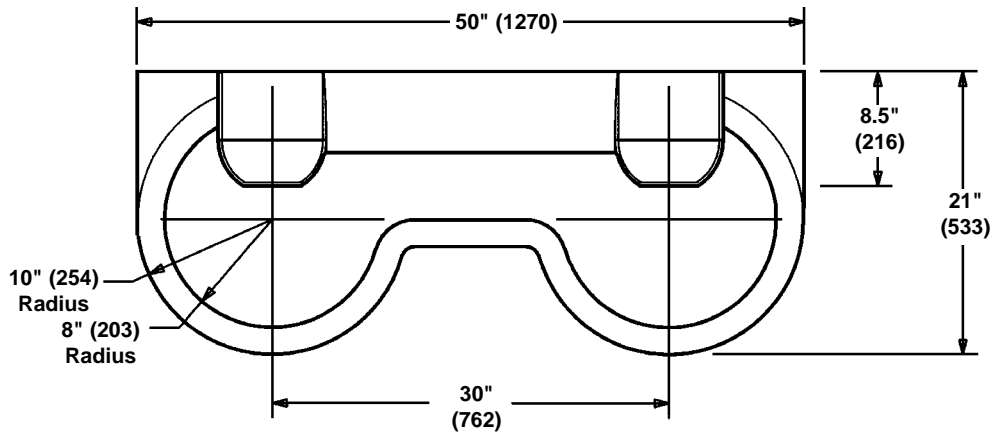
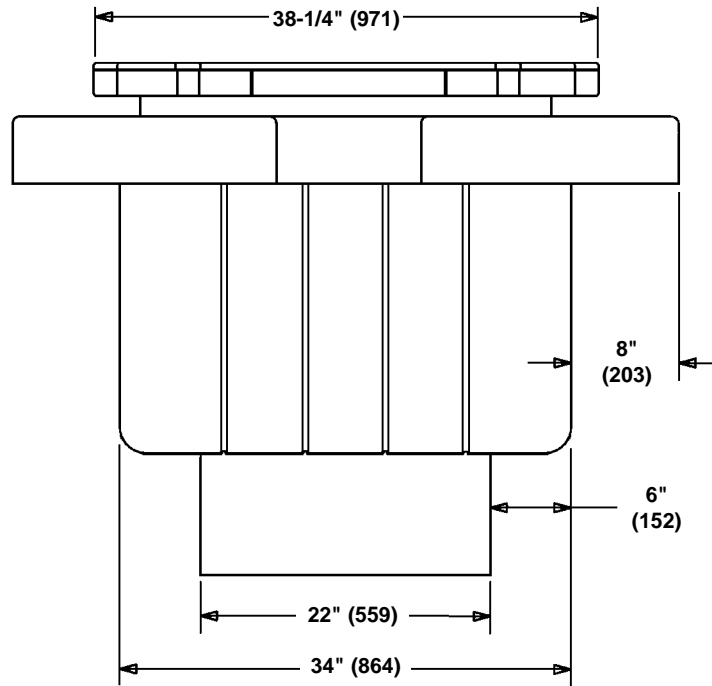

Dimensions continue . . .

Dimensions *continued* . . .

Standard Height

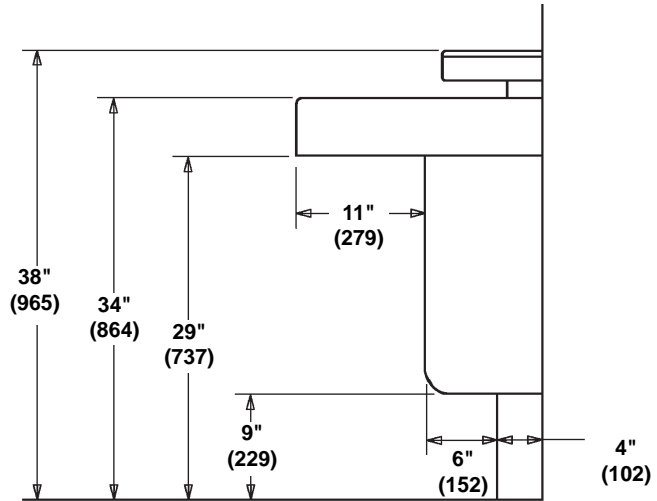

Juvenile Height

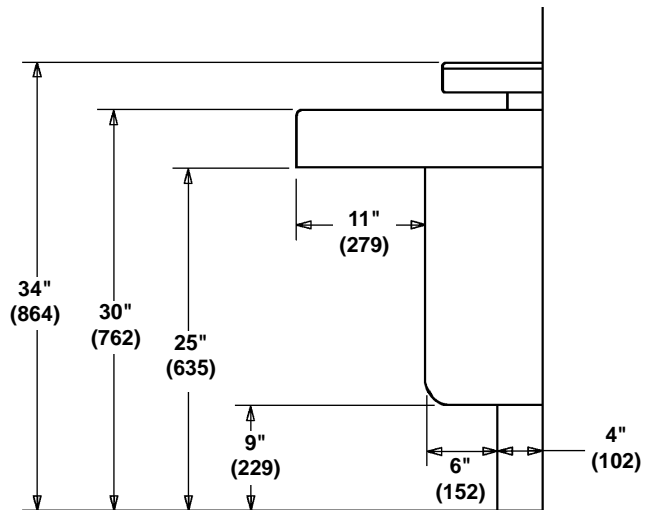

Installation Instructions

Step 1: Rough in

Note: See Figure 1 below (for Standard Height) and Figure 1a on page 6 (for Juvenile Height) when roughing in the Express®.

⚠ IMPORTANT: Flush the supply lines before making connections. Debris in supply lines can cause the valves to malfunction.

⚠ IMPORTANT: Dimensions shown in Figure 1 are for Standard Height and in Figure 1a for Juvenile Height.

1. Rough in 1/2" NPT hot and cold supply lines through wall at dimensions shown.
2. Rough in 1-1/2" NPT drain waste connection through wall at dimensions shown.
3. Install (6) 3/8" wall anchors with a minimum pull-out rating of 1,000 lbs. (supplied by installer) at the locations shown in Figures 1 and 1a.

Standard Height

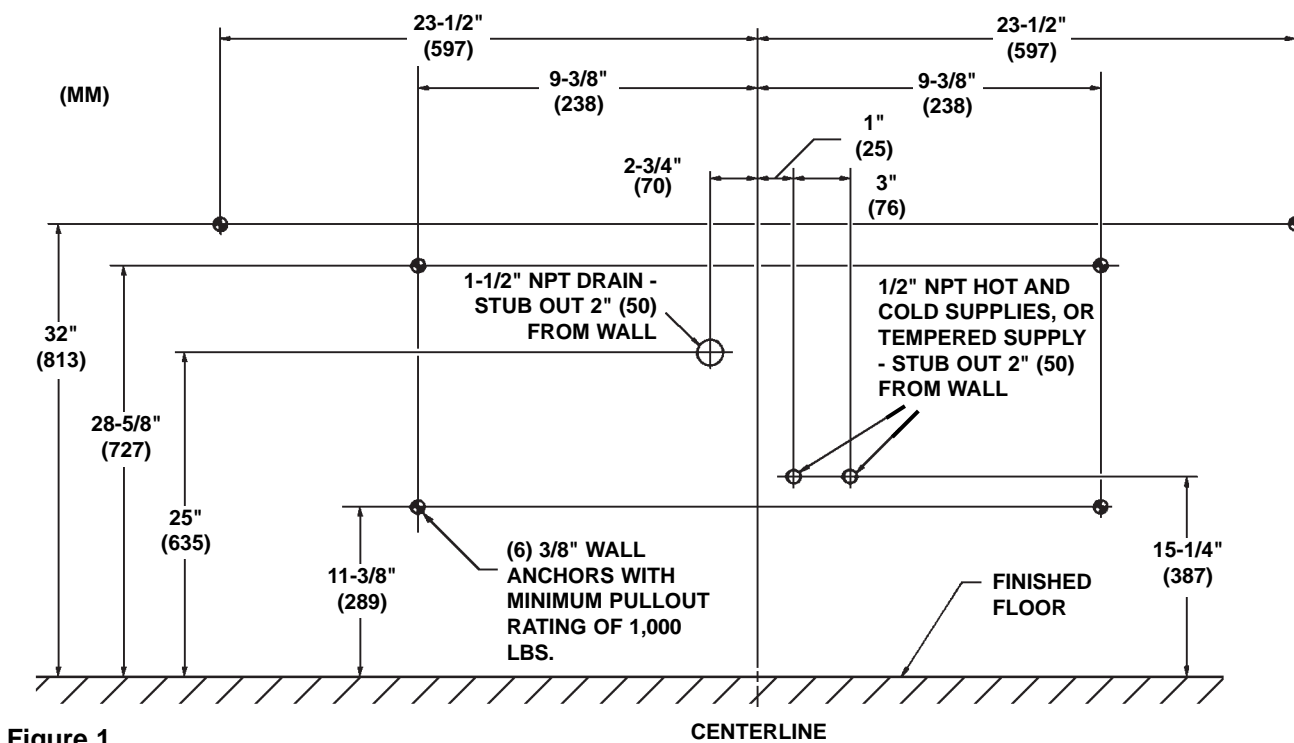

Figure 1

Installation Instructions *continue . . .*

Installation Instructions *continued* . . .

Step 2: Mounting frame to wall

1. Remove the eight Torx-head screws securing the panel to the frame, and remove the panel (see Figure 3).

Note: Scuff panel does not need to be removed.

2. Position the frame against the wall, ensuring that it is level. If necessary, insert shims under the frame until level.

Note: When mounted, the Standard and Juvenile Height frames should rest on the floor.

⚠ IMPORTANT: Anchoring the frame to a wall that is *not* flat may cause the frame to bend. If necessary, install shims to compensate for any wall distortion.

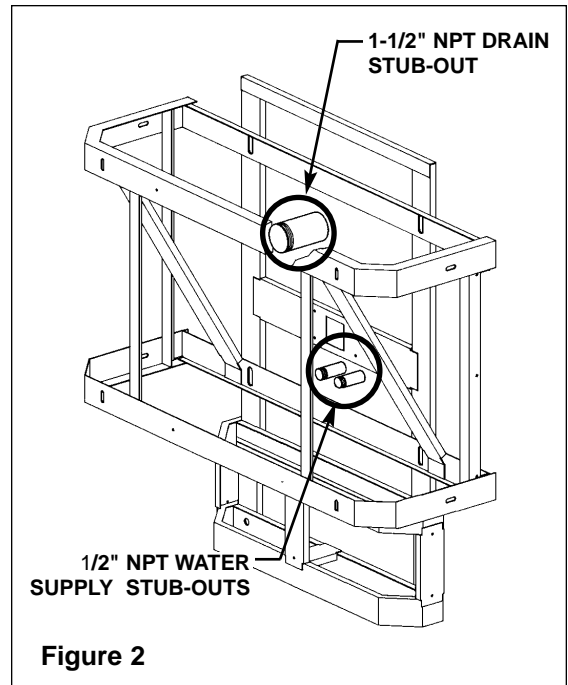

Figure 2

3. Ensure that the back of the frame is flat against the wall. If wall is not flat, insert shims behind the frame to ensure that it will not bend when anchored.
4. Once you have positioned the frame such that it is level and resting on the floor and flat against the wall or shimmed, use the 3/8" bolts and washers to mount the frame to the wall (see Figure 4).

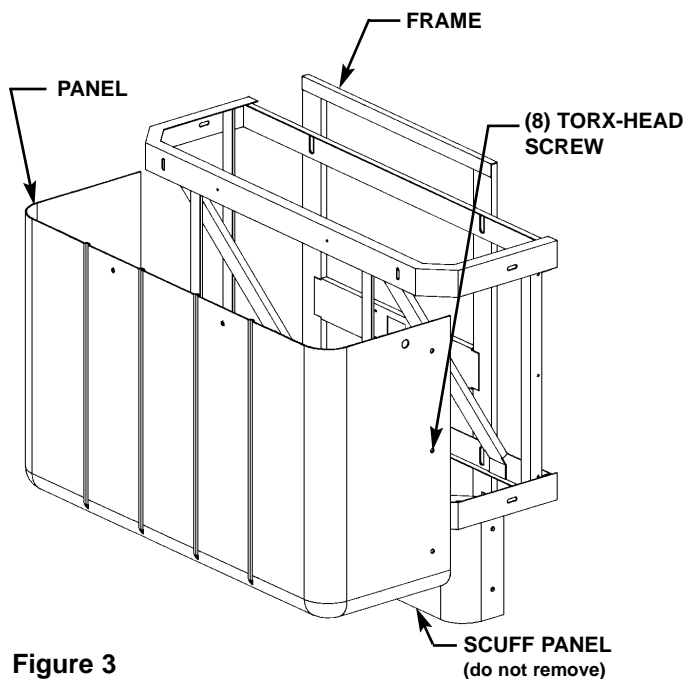

Figure 3

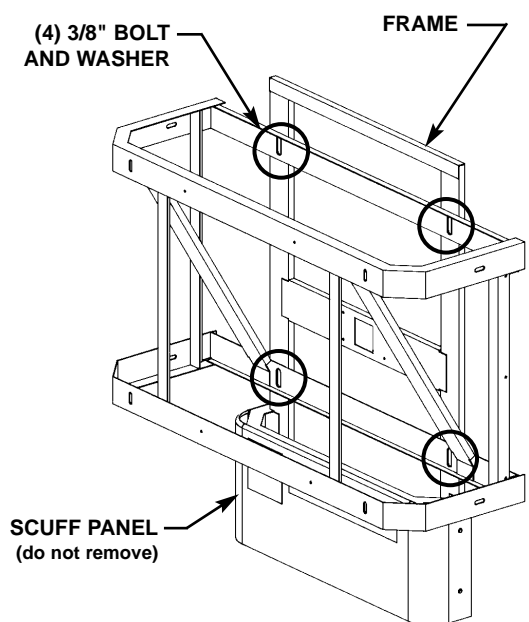

Figure 4

Installation Instructions *continue* . . .

Installation Instructions *continued* . . .

Step 3: Installing bowl assembly

⚠ IMPORTANT: Moving and positioning the bowl will require more than one person.

Note: Refer to Figure 5 below when installing the bowl assembly.

1. With someone to assist you, place the bowl assembly squarely onto the frame.
2. Attach the front of the bowl assembly to the frame using the two 1/4"-20 x 3/8" pan-head screws and washers. **Do not tighten screws at this time.**

⚠ IMPORTANT: When bolting the bowl assembly to the frame and wall, do not over-tighten bolts. Overtightening bolts can damage the Terreon® material.

3. After the bowl assembly is attached to the frame, use two 3/8" bolts and washers (supplied by the installer) to bolt the bowl to the wall anchors.
4. Tighten the screws installed in procedure #2 above to secure the bowl assembly to the frame. **Do not overtighten.**

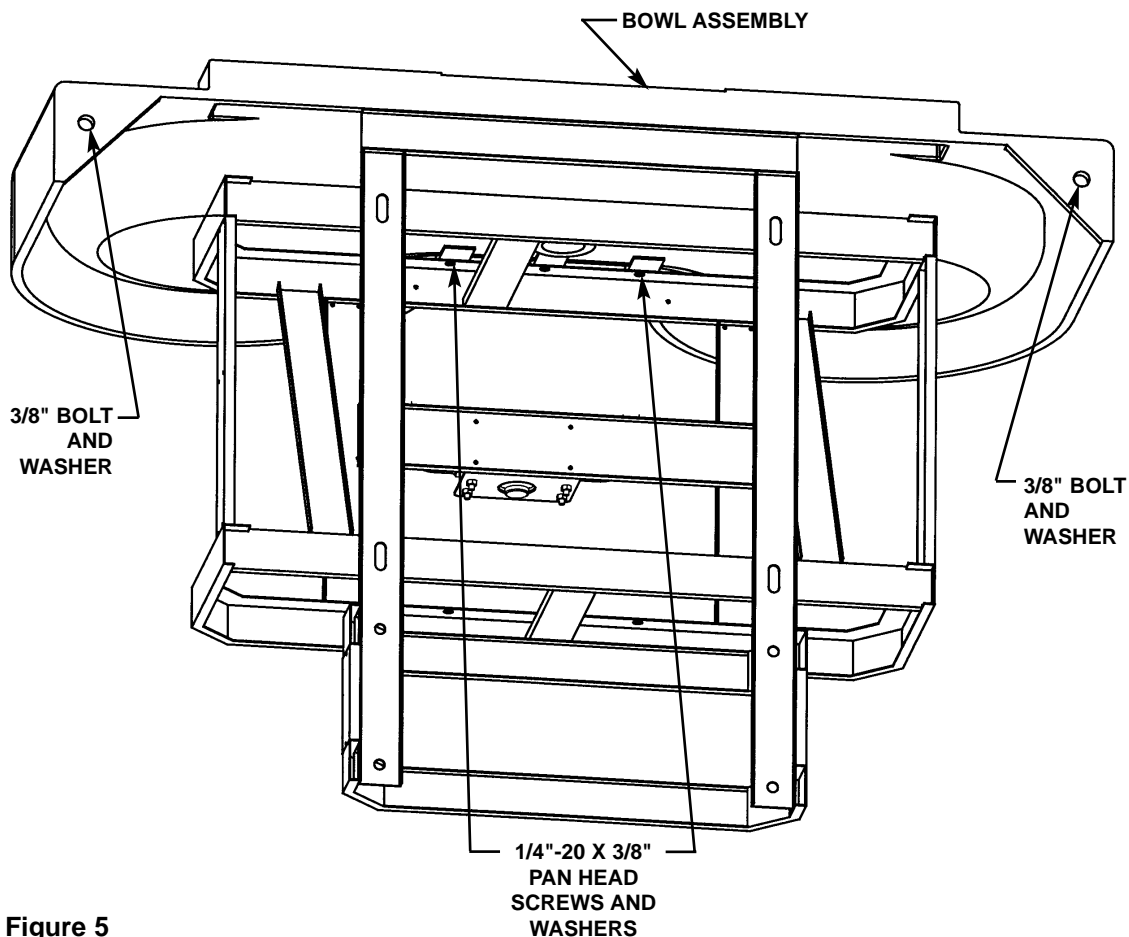

Figure 5

Installation Instructions *continue* . . .

Installation Instructions *continued* . . .

Step 4: Connecting supply and drain

1. FOR HOT AND COLD SUPPLIES: Connect the flexible hoses installed to the Vernatherm™ Mixing Valve to the hot and cold water supply piping from the wall (see Figure 6a).

Note: The red marking on Vernatherm™ Mixing Valve indicates hot water supply inlet.

FOR SINGLE TEMPERED SUPPLY: Attach the stop/strainer/check valve to the 1/2" tempered supply line. Connect the flexible hose to the stop/strainer/check valve and air valve manifold (see Figure 6b).



IMPORTANT: The plastic tubing for the water supplies and pushbuttons are pre-cut to the correct lengths. If the tubing is cut too short, kinking can occur and cause leaks at the fitting locations.

2. Connect the plastic tubing for the water supplies from the bowl assembly to the quick-connect fittings on the air valve as follows:
 - insert the tubing with the **red** marking to the left valve
 - insert the tubing with the **black** marking to the middle valve
3. Connect the plastic tubing for the pushbuttons from the bowl assembly to the quick-connect fittings on the air valve as follows:
 - insert the tubing with the **red** marking to the left valve
 - insert the tubing with the **black** marking to the middle valve
4. Assemble the P-trap (supplied) and make drain connections.

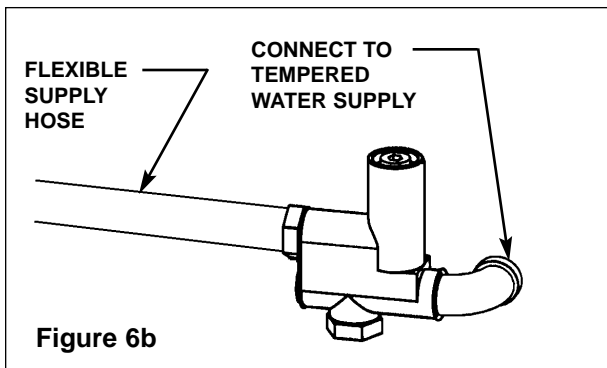
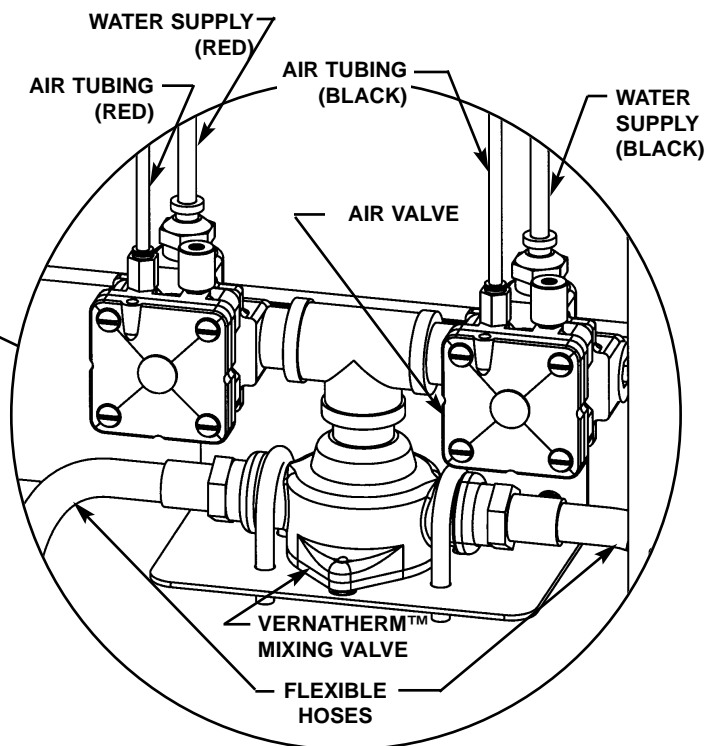
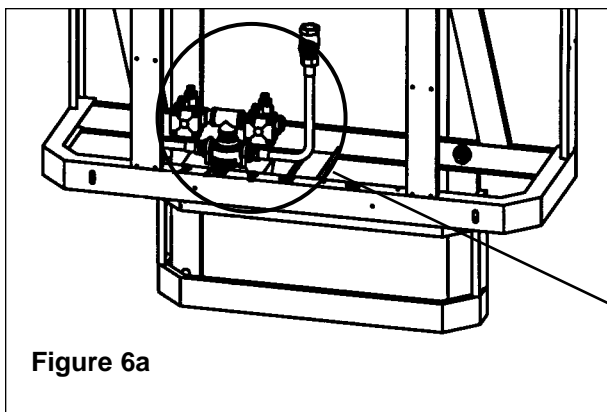

Figure 6b

Installation Instructions *continue* . . .

Installation Instructions *continued . . .*

Step 5: Completing installation

1. Turn on the water supply to the Express® lav and check for leaks.
2. Install the panel to the frame. Fasten panel with the eight Torx-head screws provided (see Figure 7 below).

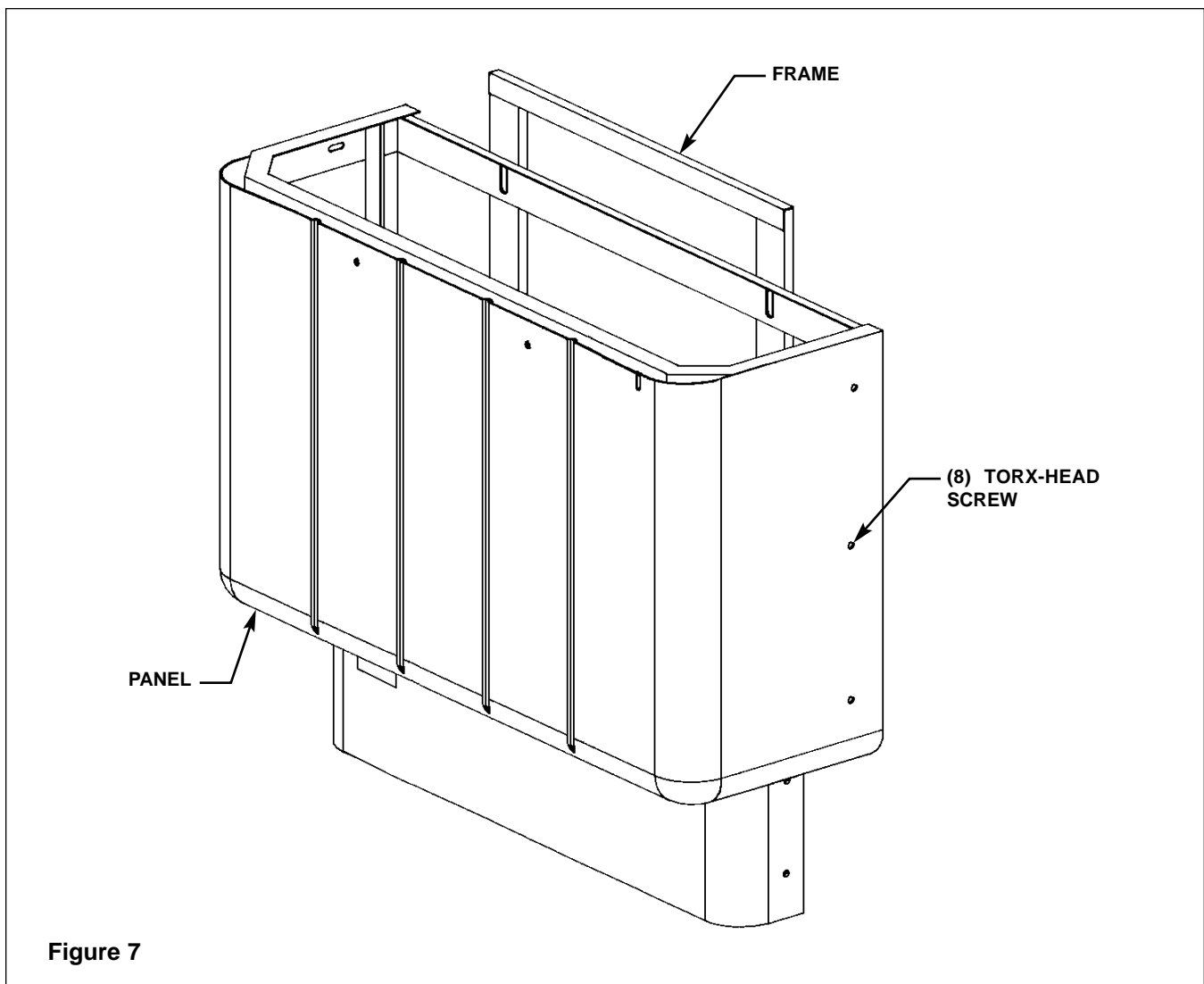

Cleaning and Maintenance Instructions



IMPORTANT: Strong alkaline or acid-based chemicals and cleansers should not be used to clean Terreon®. If these chemicals come in contact with the Terreon® surface, wipe off the surface immediately and flush with soapy water.

Terreon® and panel maintenance

The bowl and sprayhead cover are constructed of Terreon®, a densified solid surface material composed of an acrylic modified polyester resin. Terreon® is resistant to chemicals, stains, burns and impact. Surface damage can be easily repaired with everyday cleaners or fine grit abrasives. The panel and sprayhead are made of an acrylic/ABS laminate, and will not chip, peel or flake. With regular cleaning, your Terreon® fixture will provide years of dependable service.

Cleaning

- **Daily Cleaning:** Wipe the surface with a damp cloth and wipe dry.
- **Weekly Cleaning:** Wipe the surface with a damp cloth and a household liquid detergent. Stubborn stains can be removed as follows:
 1. Using a #7448 Scotch-Brite® pad, scrub with an abrasive cleanser such as Ajax®, Comet® or Soft Scrub® and water.
 2. Clean thoroughly with soapy water and allow to dry.
- **Scorch Marks:** Although Terreon® will not burn, a lit cigarette in contact with Terreon® could leave a scorch mark. Scorch marks can be removed by buffing with a #7448 Scotch-Brite pad or with an abrasive cleaner.
- **Repair kit:** In the unlikely event your Terreon® surface becomes damaged, it can easily and expensively be repaired. Contact your Bradley representative to order a repair kit and be sure to specify color when ordering.

Panel cleaning



IMPORTANT: Do not use abrasive cleansers to clean the panel or sprayhead body. Abrasive cleaners can mar the surface.

- **Graffiti/Vandalism:** If vandals create markings on the panel, Bradley recommends using Motsenbocker's LIFT OFF® to remove ink and spray paint. Remover #3 is for ink and markers, and Remover #4 is for spray paint. Motsenbocker's LIFT OFF® can be ordered through Sanitary Maintenance Service Inc. (call 1-800-451-5523 x 425 or visit www.sanitarymaintenance.com/product.htm for ordering information). After cleaning with LIFT OFF®, give the panel a final thorough cleaning with a liquid tub and tile cleaner to remove soil and maintain the glossy finish.

NOTE: Use of brand names is intended only to indicate a type of cleaner. This does not constitute an endorsement, nor does the omission of any brand name cleaner imply its inadequacy. Many products named are regional in distribution and can be found in local supermarkets, department and hardware stores or through your cleaning service. It is emphasized that all products should be used in strict accordance with package instructions.

Soap Dispenser Maintenance

Step 1: Fill soap dispensers

The two soap valves will dispense vegetable/coconut oil liquid soaps, synthetic detergents, viscous lotion soaps, and antiseptic solutions. A 10-15% concentration is recommended for vegetable or coconut oil liquid soaps. Synthetic detergents, lotion soaps, and antiseptic soaps require no dilution.

1. Using two screwdrivers (or similar tool), push up on the release tabs located beneath each soap dispenser and pull out the soap tanks from the sprayhead (see Figure 8a).
2. To remove packing dust, rinse out each soap tank with hot water. Shake water out thoroughly and allow to dry.
3. Pour the soap into each soap tank's filler hole (see Figure 8b).
4. After each soap tank is filled, position the soap tanks into the sprayhead openings and push into place.

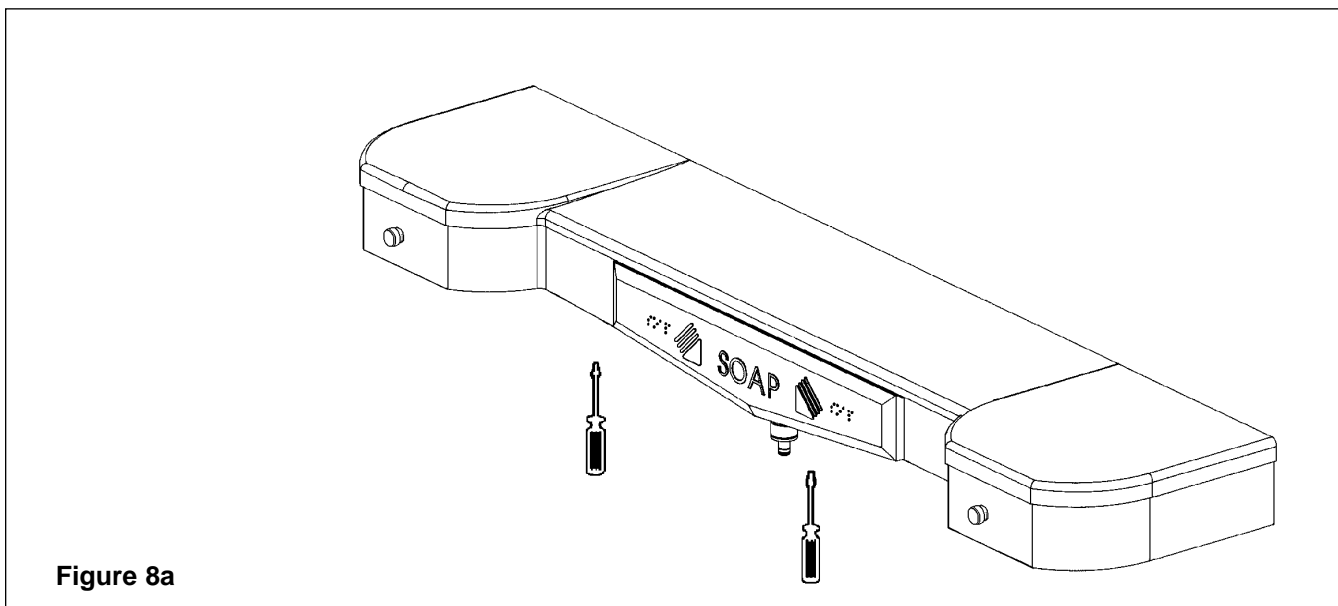

Figure 8a

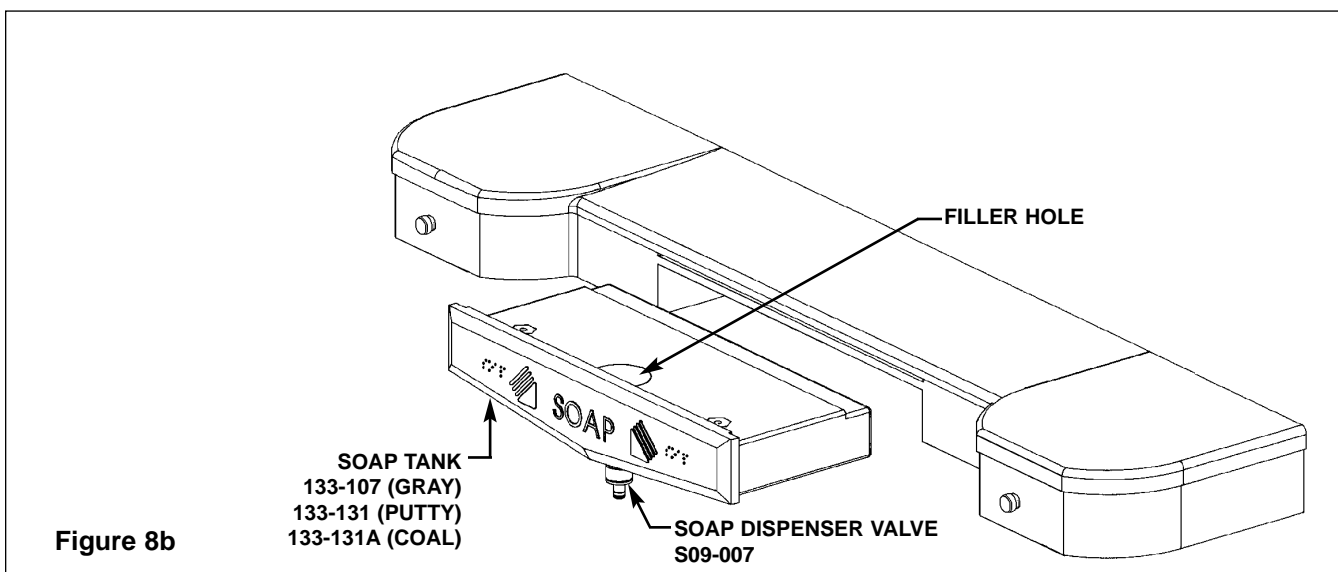

Figure 8b

Soap Dispenser Maintenance *continued* . . .

Step 2: Change soap type

1. Pour out all of the soap from the dispenser.
2. Rinse the soap dispenser with hot water several times until all of the residue is removed, and pump the valve until clean water appears.
3. Rinse the dispenser with ethyl alcohol and allow to air dry.
4. After the dispenser is dry, pour the new soap into the soap dispenser.

Step 3: Cleaning Instructions

Regular cleaning of the soap dispenser is recommended to ensure optimum performance and maximum service life. Cleaning the soap dispenser monthly to remove soap residue, dirt, and other accumulations should become a regular part of your washroom cleaning routine and general maintenance program.



IMPORTANT: Do not use abrasive cleansers to clean the soap tank. Abrasive cleansers can mar the surface.

Clean exterior: Use warm water and soap to clean the exterior of the soap dispenser. Dry with a soft cloth.

Clean interior: Inspect the interior of the soap tank for residue or coagulation of soap. If necessary, clean the soap tank according to the following procedure:

1. Pour out any remaining soap in the tank.
2. Fill the tank half-full of hot water and shake the tank to dislodge the soap residue.
3. Empty the water from the container and repeat steps 1 and 2 until the soap container is clean.

NOTE: If rinsing alone does not remove the soap residue, place a small chain (24 inches long) into the soap tank with hot water and shake the container until the chain dislodges the residue. Then remove the chain and rinse out the soap tank.

Clean internal components: To clean the internal components of the soap dispenser, pump hot water through the soap dispenser until a clean flow of water comes out of the valve.

Check Valve Troubleshooting

If water just dribbles or does not flow from sprayhead:

1. Close the stops and check the valves that supply water to the lavatory system.
2. Inspect the stop/check valves for proper installation.
3. Remove the flexible hoses from the stop/check valves and clean the strainers, if necessary.

If water sprayhead delivers all hot or cold water:

1. Close the stops and check the valves that supply water to the lavatory system.
2. Inspect the stop/check valves for proper installation.
3. Remove the flexible hoses from the stop/check valves and clean the strainers, if necessary.
4. Inspect mixing valve for proper installation (see Vernatherm valve on page 18).
 - A red marking indicates the hot inlet.

Assembly of Components

Paneling

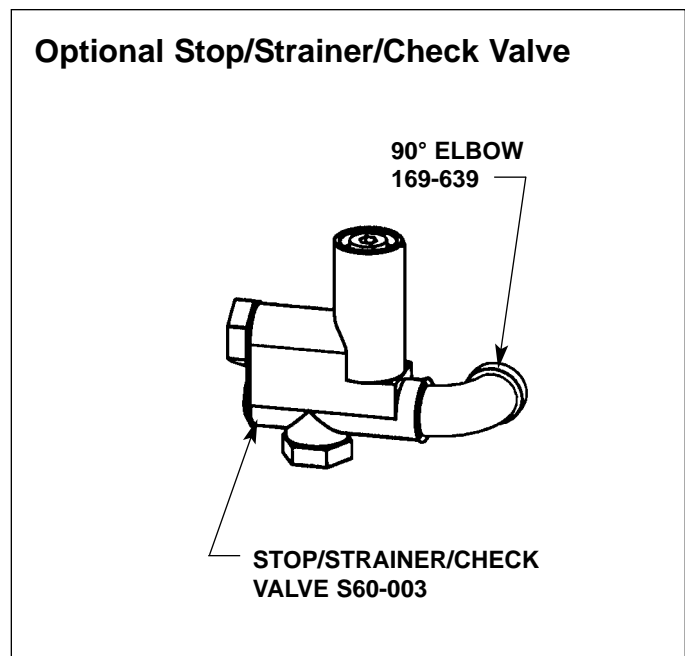
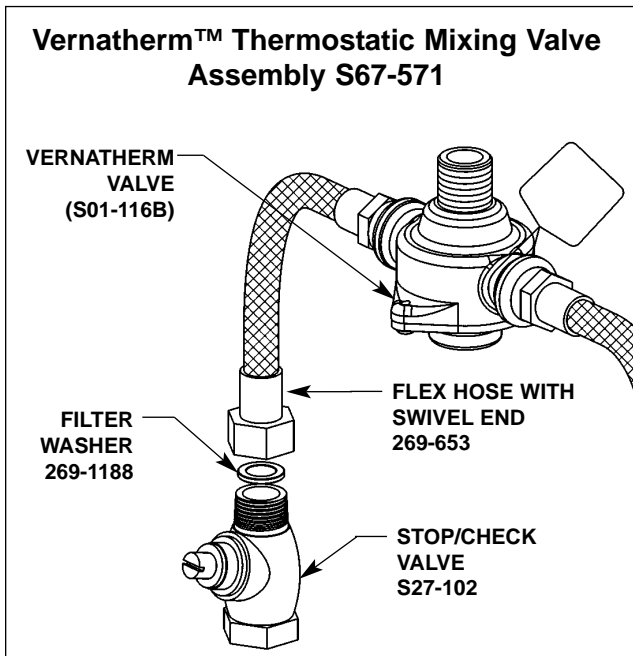
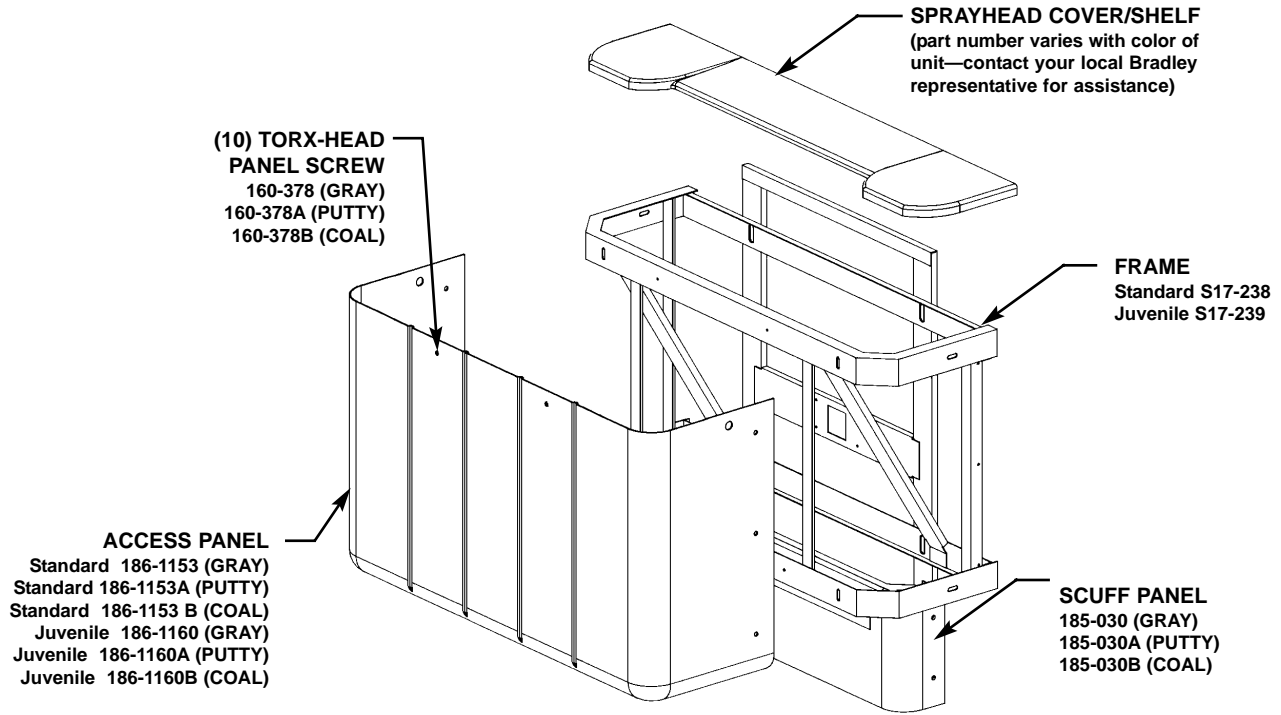

Assembly of Components *continued* . . .

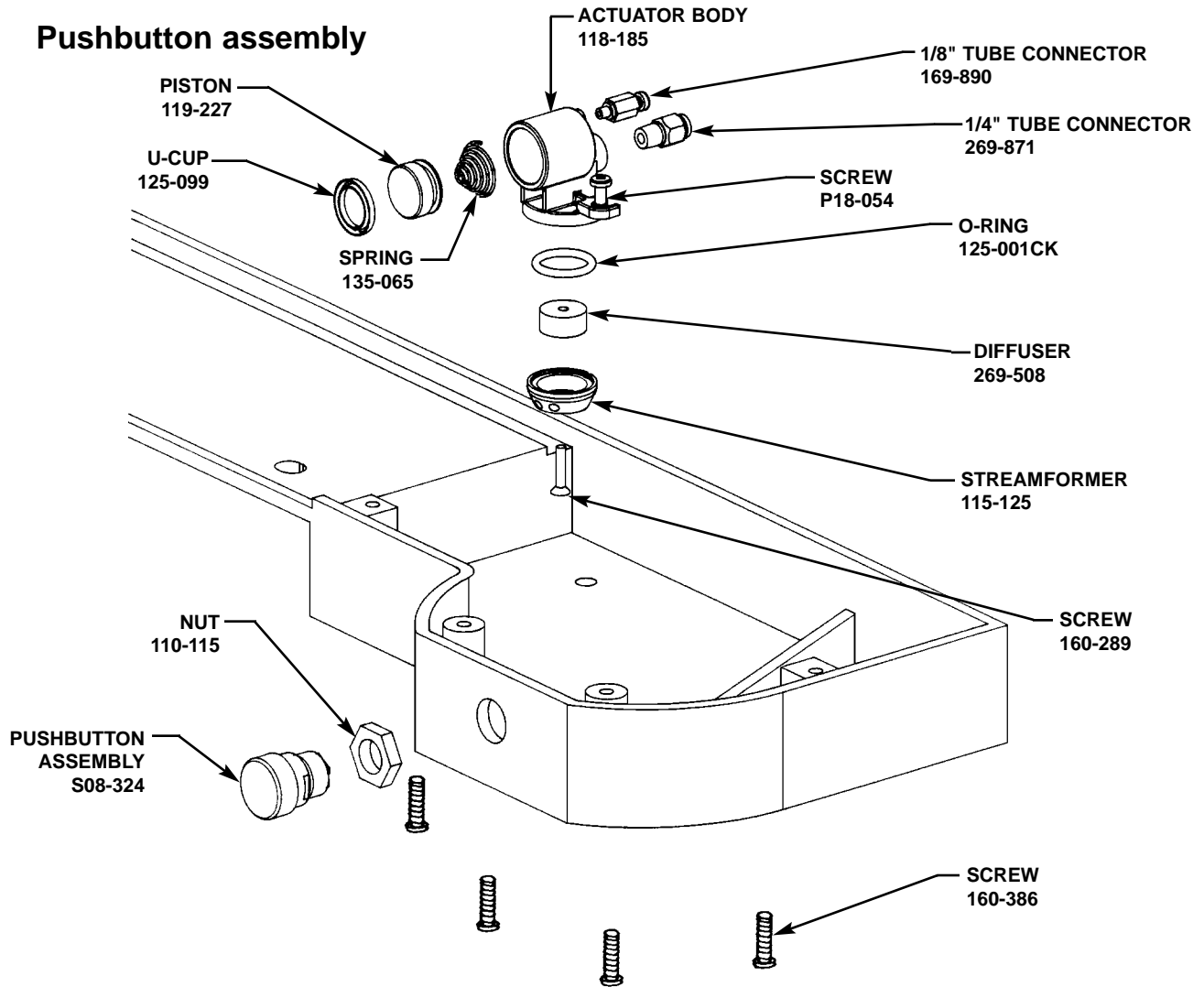

Other Replacement Parts

BOWL MOUNTING HARDWARE

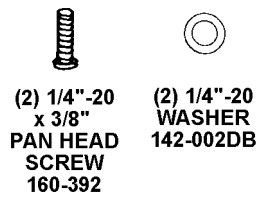

Drain Assembly

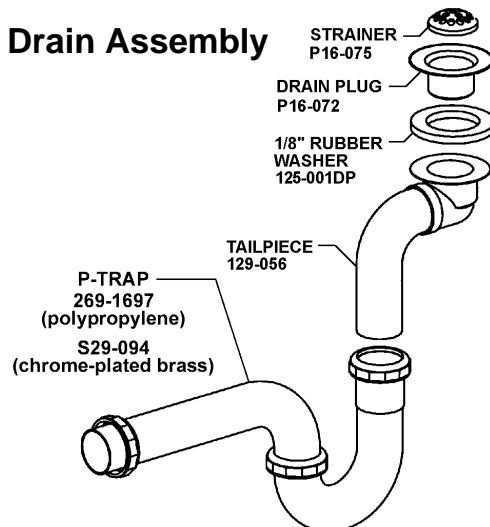

Metering Air Valve Maintenance

Metering Air Valve Repair Kits and Parts List

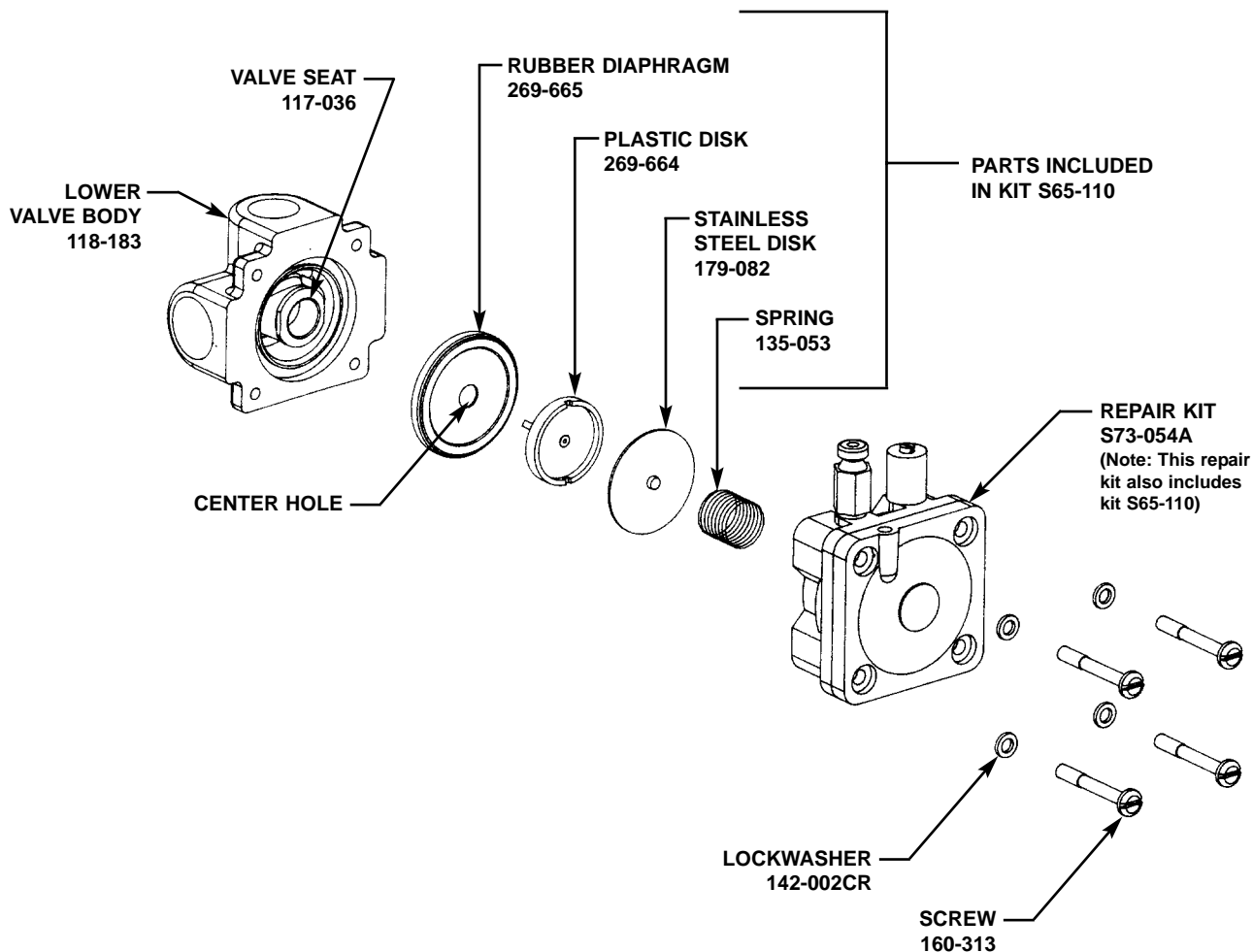

Metering Air Valve Troubleshooting

Problem: Water is dripping from the streamformers

Cause: Debris on valve seat or orifices.

Solution: Clean and inspect the valve seat.

1. Remove screws and disassemble metering valve.
2. Clean the valve seat and inspect for deep gouges or scratches. Replace if necessary.
3. Remove all debris that may be clogging center hole of plastic diaphragm assembly.
4. Remove any debris clogging the off-center hole in the rubber diaphragm.

Metering Air Valve Troubleshooting *continued . . .*

Metering Air Valve Troubleshooting

Problem: Valve will not shut off.

Cause: Timing mechanism is clogged.

Solution: Clean timing mechanism:

1. If compressed air is available, blow water and debris from perforated metal sleeve of timing mechanism.
2. Turn the adjusting screw in all the way but do not force screw.
3. Turn adjusting screw out to desired cycle time.

Problem: Valve will not turn on.

Cause: Water is not being supplied to the unit.

Solution: Open all stops on the mixing valve.

Problem: Timing can not be adjusted for more than 5 seconds.

Cause: There is an air leak

Solution: Check assembly:

1. Check all tubing and fittings for proper assembly.
2. Tighten all screws which hold valve together.

Problem: Pushbutton does not work properly.

Cause: Air volume may not be sufficient to operate valve.

Solution: Check for leaks and lubricate U-cup:

1. Check all fittings for air leaks.
2. Disassemble pushbutton and lubricate U-cup seal (see pushbutton assembly diagram on page 15).

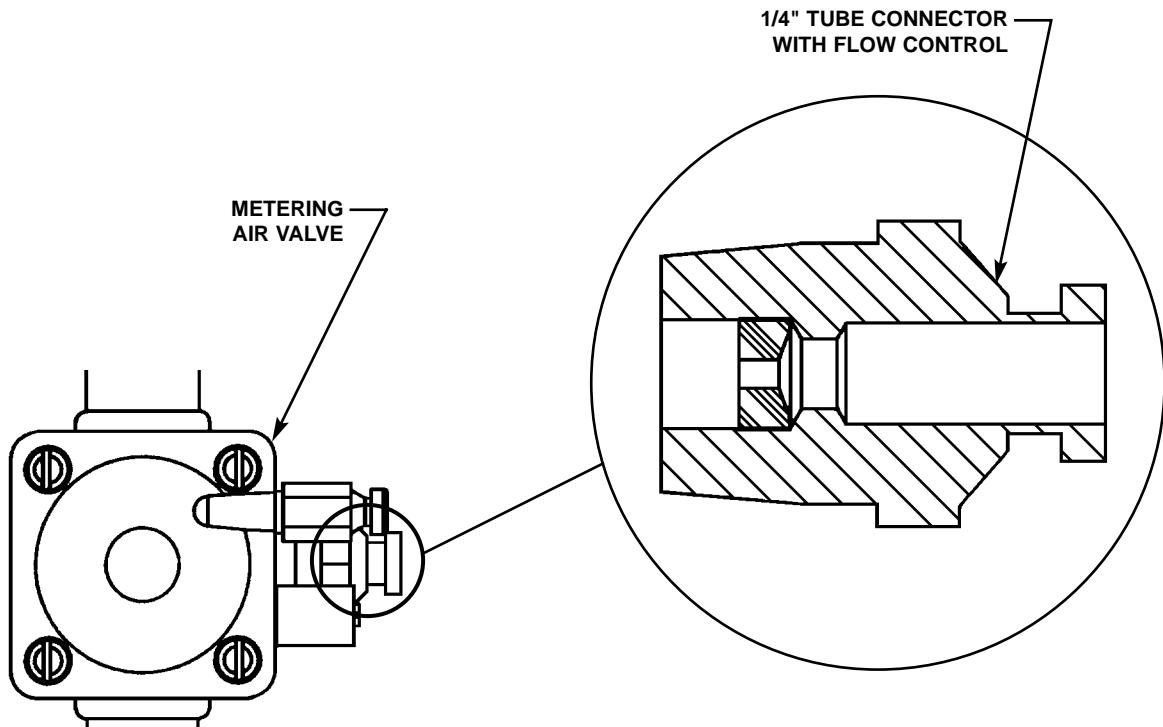

Vernatherm™ Mixing Valve Maintenance and Service

*Repair kit S45-049 is pre-packaged and includes O-Ring, Flip Ring, Power Element and Spring.

Maintenance Instructions

1. Disassemble the Vernatherm™ Valve as shown, being careful not to damage the power element. Replace the element, if necessary.
2. If necessary, remove the old flip ring and replace with a new ring.

NOTE: An old or worn flip ring may cause temperature fluctuation and/or water chatter.

3. Reassemble the power element and valve body. Apply grease to the main valve slide and gently ease into position, rotating so that grease is applied to the flip ring. Do not force the slide as this may push the flip ring from its position. To test, rotate the slide; a slight drag should be felt when correctly installed.
4. Reassemble the valve.

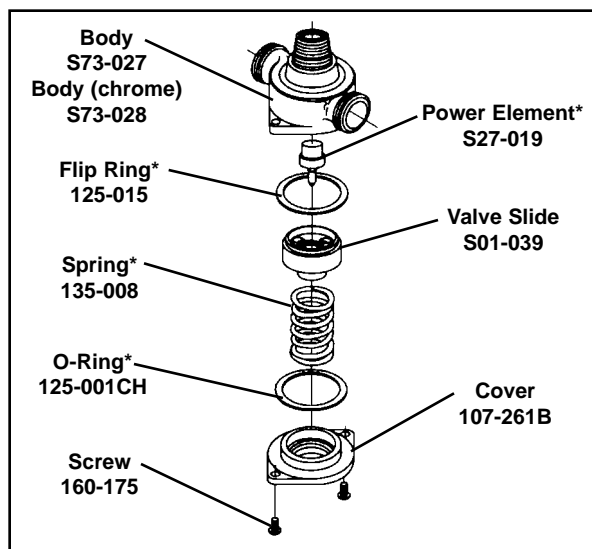

Service Suggestions

When servicing the valve, make sure it is installed in the correct position. The most common error occurs when the valve is installed in the reversed position, that is, the hot line is connected to the cold line and the cold is connected to the hot.

NOTE: A red marking indicates the hot side of the valve.

The table below lists conditions that occur when the valve is installed correctly, and when it is in the reversed position.

IF		THEN	
Valve Position is	Hot Supply	Cold Supply	Valve Delivers
Correct	Hot	Cold	Mixed 107°
Correct	Hot	No Water	Valve shuts off or drips
Correct	No Water	Cold	Valve shuts off or drips
Correct	Hot	Hot	Hot
Correct	Cold	Cold	Cold
Reversed	Hot	Cold	Cold/below 107° Hot/above 107°
Reversed	Hot	No Water	Hot
Reversed	No Water	Cold	Cold
Reversed	Hot	Hot	Hot
Reversed	Cold	Cold	Cold