

Installation Instructions **OBSOLETE**

**SS-2/IR/STD
SS-2/IR/JUV**

Express® Lavatory System SS-Series

(Standard* and Juvenile Height)

*Express® Lavatory Systems
are ADA compliant.



 **IMPORTANT**

Read this entire installation manual to ensure proper installation, then file these instructions with the owner or maintenance department.

Flush all the water supply lines before making connections.

Wall anchors used must have a minimum pull-out rating of 1,000 lbs.

Product warranties may be found under "Product Information" on our web site at www.bradleycorp.com.

Table of Contents

Pre-Installation Information	2
Dimensions	3-4
Installation Instructions	5-11
Cleaning and Maintenance Instructions	12
Soap Dispenser Maintenance	13-14
Wiring Diagram	14
Assembly of Components	15-16
Check Valve Troubleshooting	17
Solenoid Valve Troubleshooting	17-18
Vernatherm™ Valve Maintenance & Service ..	19

Pre-Installation Information

Barrier-free and ADA compliant - standard height mounting

The SS-2/IR/STD Express® Lavatory System must have a rim height of 34" above finished floor to be compliant with Americans with Disabilities Act (ADA). When mounted at 34" rim height, the Express® meets ADA, ANSI and UFAS requirements for barrier-free clearances, reaches and controls. Always check local codes and ordinances for compliance.

Barrier-free and ADA compliant - juvenile height mounting

The SS-2/IR/JUV Express® Lavatory System is compliant with Americans with Disabilities Act (ADA) Accessibility Guidelines for Buildings and Facilities: Building Elements Designed for Children's Use; Final Rule.

Infrared sensor and solenoid

Each sprayhead is controlled by a separate sensor and solenoid valve, enabling each user to activate a single flow of water. Each valve uses less than half the maximum of hot water allowed by the ANSI/ASHRAE/IES 90A-1980 Standard.

Supplies required for installation:

- (6) 3/8" wall anchors, bolts and washers to mount frame and bowl to wall (minimum pull-out rating of 1,000 lbs.)
- 1/2" NPT hot and cold supply piping
- 1-1/2" NPT drain piping
- 110 volt electrical outlet for 110/24 VAC plug-in transformer (supplied)

SS-2/IR/STD Express® Lavatory System Dimensions

Standard Height Mounting

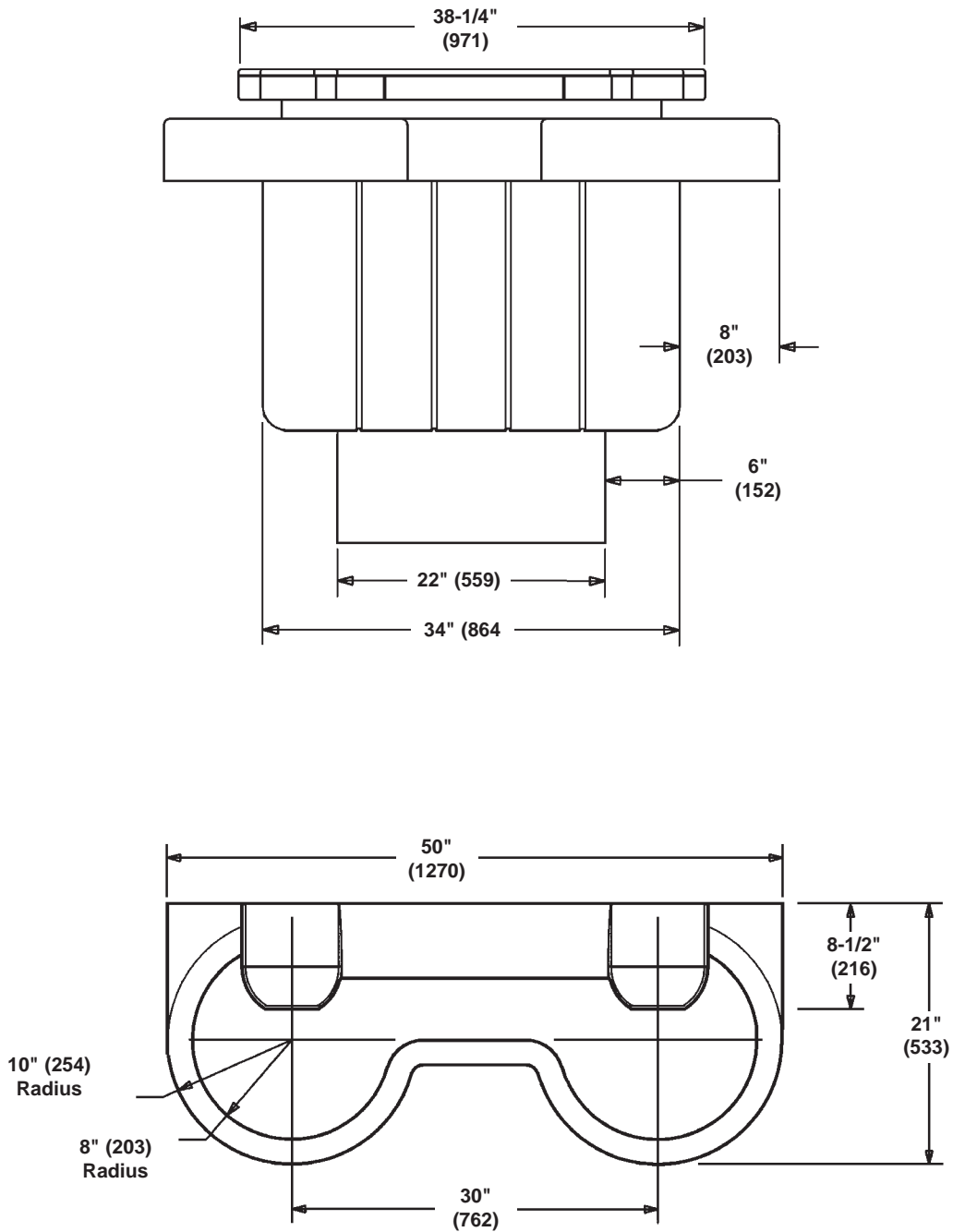

**Standard Height
SS-2/IR/STD**

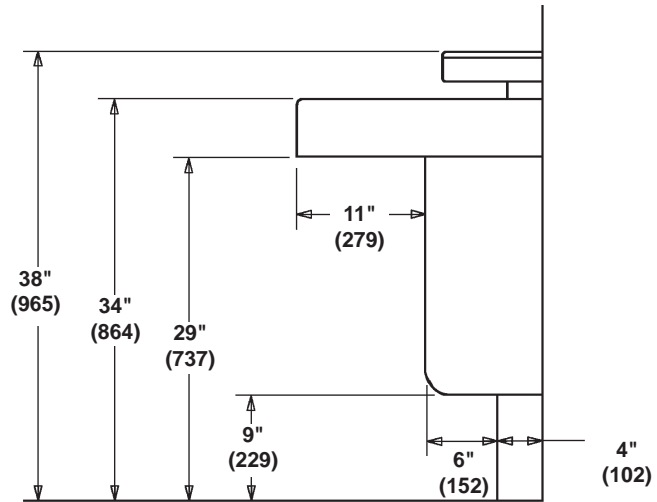

**Juvenile Height
SS-2/IR/JUV**

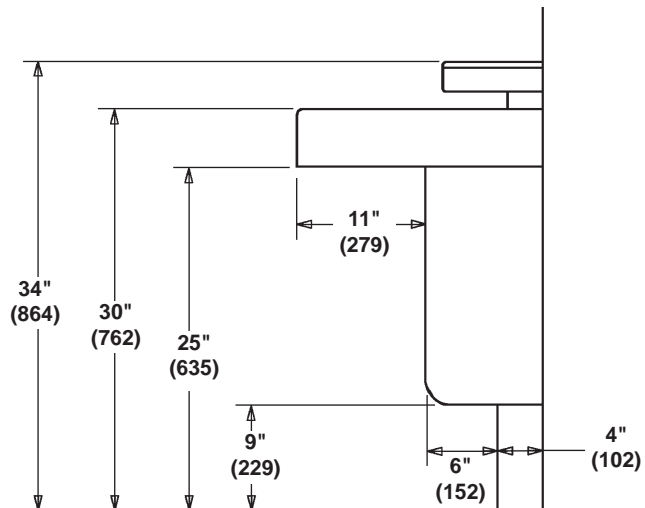

Installation Instructions

Step 1: Rough in

Note: See Figure 1a below (for Standard Height) and Figure 1b on page 6 (for Juvenile Height) when roughing in the Express®.

⚠ IMPORTANT: Flush the supply lines before making connections. Debris in supply lines will cause the valves to malfunction.

⚠ IMPORTANT: Dimensions shown in Figure 1a are for a Standard Height Express® only.

1. Rough in 1/2" NPT hot and cold supply lines through wall at dimensions shown.
2. Rough in 1-1/2" NPT drain waste connection through wall at dimensions shown.

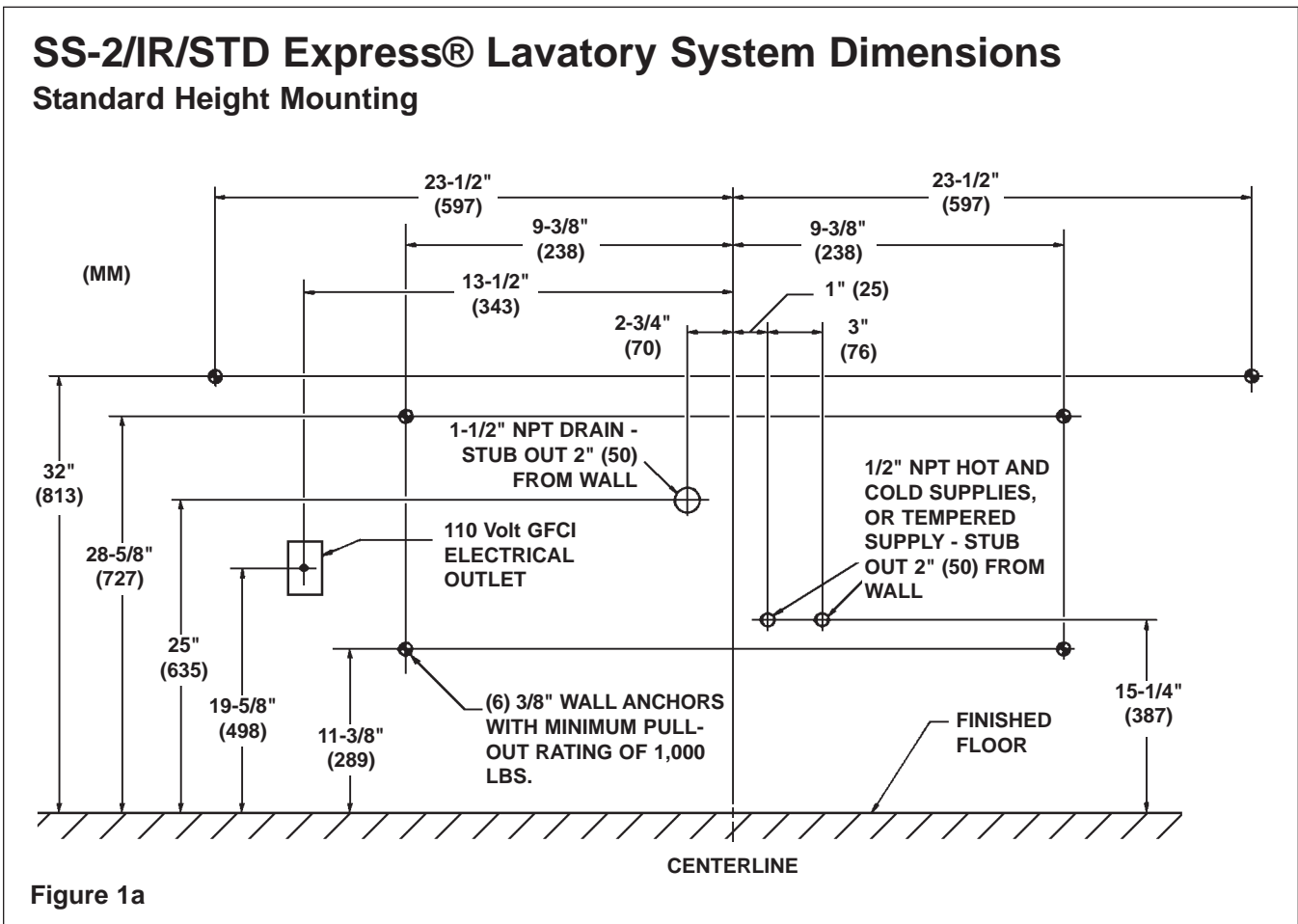

Installation Instructions *continue . . .*

SS-2/IR/JUV Express® Lavatory System Dimensions Juvenile Height Mounting

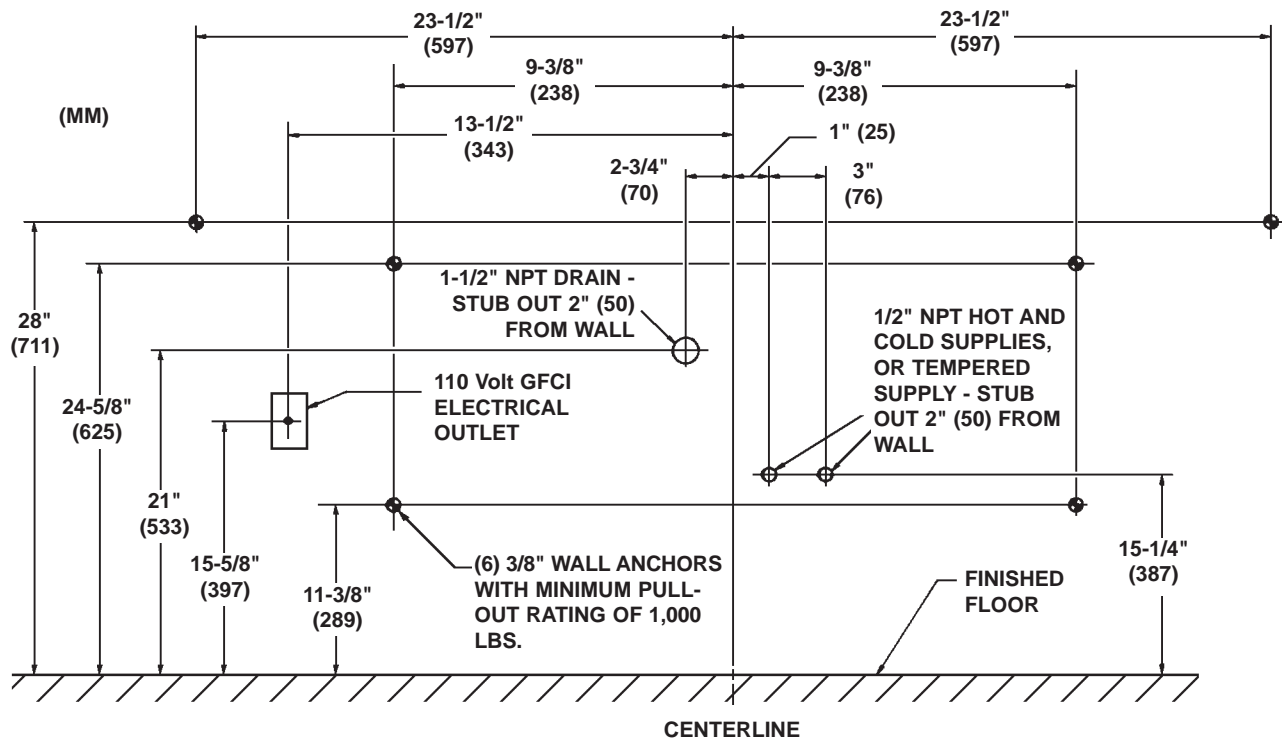

Figure 1b

Installation Instructions *continue . . .*

Installation Instructions *continued . . .*

Step 1: Rough in *continued . . .*

⚠ IMPORTANT: Turn OFF electrical power to the outlet when installing the Express®.

3. Install the 110 volt GFCI electrical outlet per local code at the location shown in Figure 2.
4. Install (6) 3/8" wall anchors with a minimum pull-out rating of 1,000 lbs. (supplied by installer) at the locations shown in Figures 1a or 1b on pages 5-6.

NOTE: The anchors will be used to mount the Express® bowl and frame to the wall.

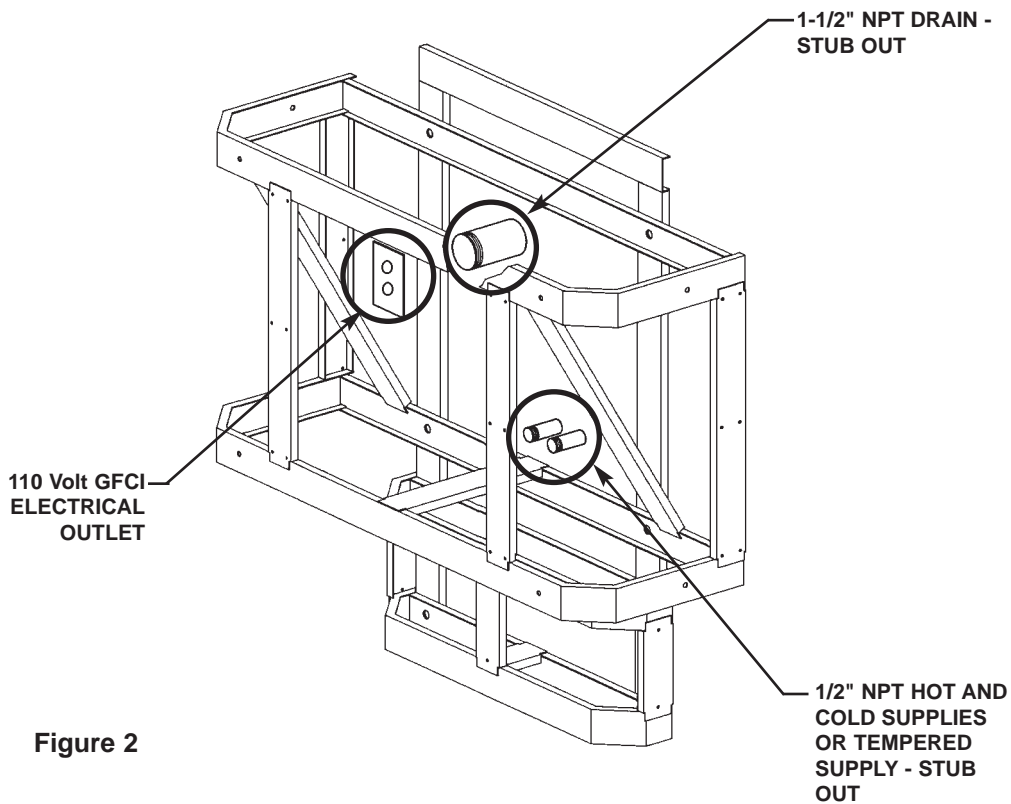

Figure 2

Installation Instructions *continue . . .*

Installation Instructions *continued* . . .

Step 2: Mounting frame to wall

1. Remove the eight Torx-head screws securing the panel to the frame, and remove the panel (see Figure 3).

Note: Scuff panel does not need to be removed.

2. Position the frame against the wall, ensuring that it is level. If necessary, insert shims under the frame until level.

Note: When mounted, the Standard and Juvenile Height frames should rest on the floor.

⚠ IMPORTANT: Anchoring the frame to a wall that is *not* flat may cause the frame to bend. If necessary, install shims to compensate for any wall distortion.

3. Ensure that the back of the frame is flat against the wall. If wall is not flat, insert shims behind the frame to ensure that it will not bend when anchored.
4. Once you have positioned the frame such that it is level and resting on the floor, and flat against the wall or shimmed, use four 3/8" bolts and washers to mount the frame to the wall (see Figure 4).

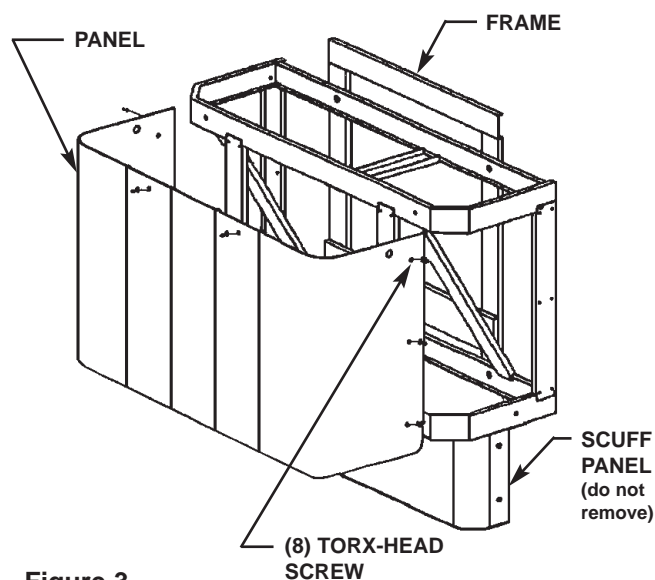

Figure 3

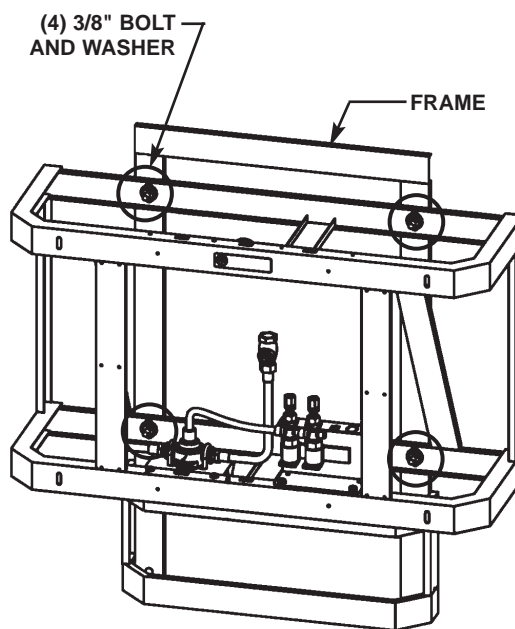

Figure 4

Installation Instructions *continued . . .*

Step 3: Installing bowl assembly



IMPORTANT: Moving and positioning the bowl will require more than one person.

Note: Refer to Figure 5 below when installing the bowl assembly.

1. With someone to assist you, place the bowl assembly squarely onto the frame.
2. Attach the front of the bowl assembly to the frame using the two 1/4"-20 x 3/8" pan-head screws and washers. **Do not tighten screws at this time.**



IMPORTANT: When bolting the bowl assembly to the frame and wall, do not over-tighten bolts. Overtightening bolts can damage the Terreon® material.

3. After the bowl assembly is attached to the frame, use two 3/8" bolts and washers (supplied by the installer) to bolt the bowl to the wall anchors.
4. Tighten the screws installed in procedure #2 above to secure the bowl assembly to the frame. **Do not overtighten.**

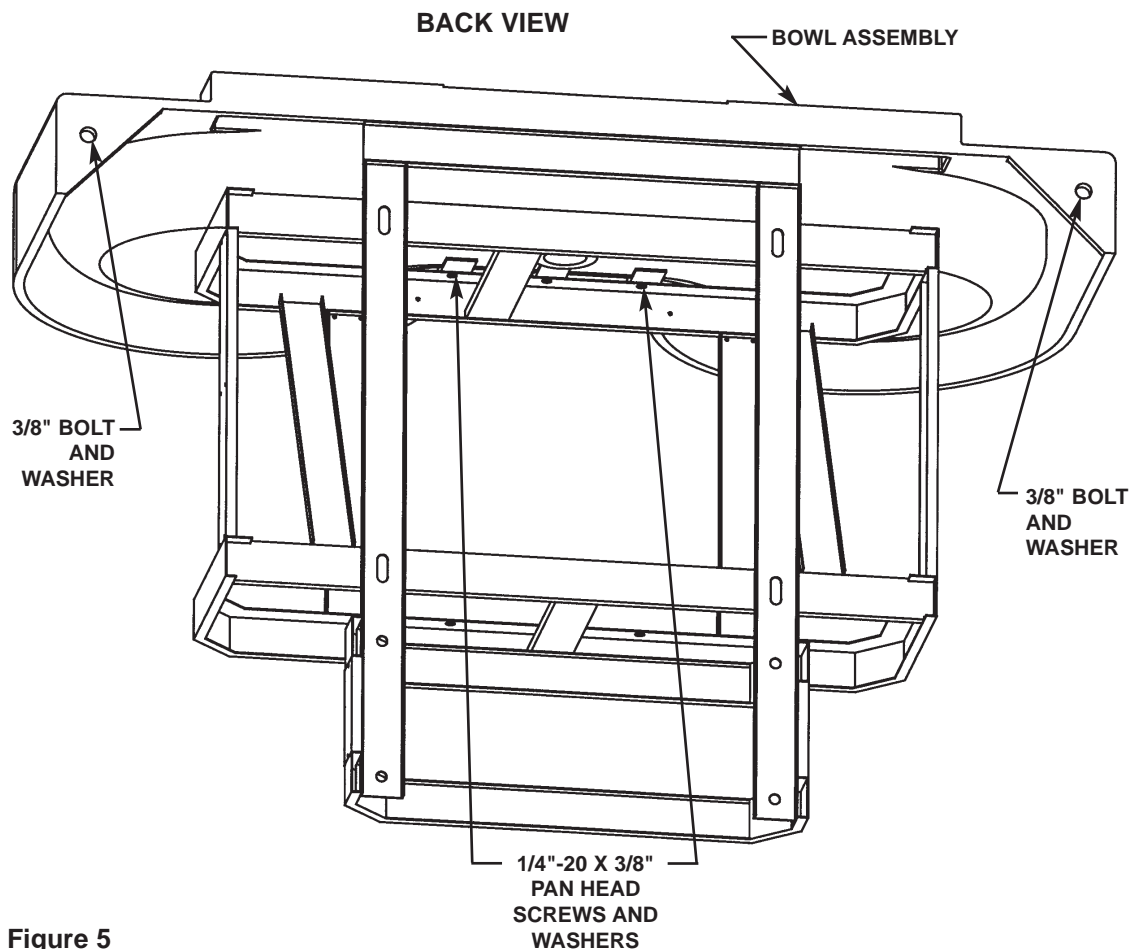

Figure 5

Installation Instructions *continue . . .*

Installation Instructions *continued . . .*

Step 4: Connecting supply and drain

1. FOR HOT AND COLD SUPPLY: Connect the flexible hoses installed to the Vernatherm™ Mixing Valve to the hot and cold water supply piping from the wall (see Figure 6a).

Note: The red marking on Vernatherm™ Mixing Valve indicates hot water supply inlet.

FOR SINGLE TEMPERED SUPPLY: Attach the stop/check/strainer to the 1/2" tempered supply line. Connect the stop/check/strainer to the solenoid valves with the flexible supply hose (see Figure 6b).

2. Install the drain plug in the hole in the bottom of the bowl (see Figure 7).
3. Beneath the bowl, install the 1/4" rubber washer onto the drain plug, and thread the tailpiece to the drain plug.
4. Assemble the P-trap by connecting the 1-1/2" tubular pipe to the tailpiece and to the 1-1/2" drain pipe stubbed out of the wall.
5. Install the strainer on the drain plug opening inside the bowl, and push the strainer firmly into place.

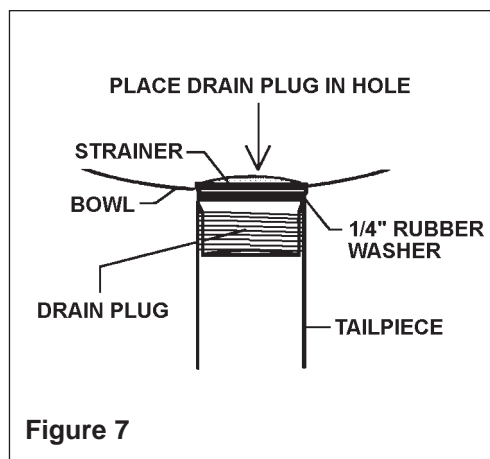
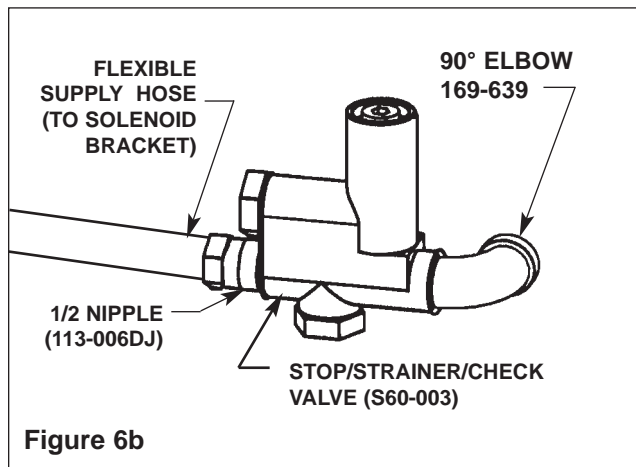
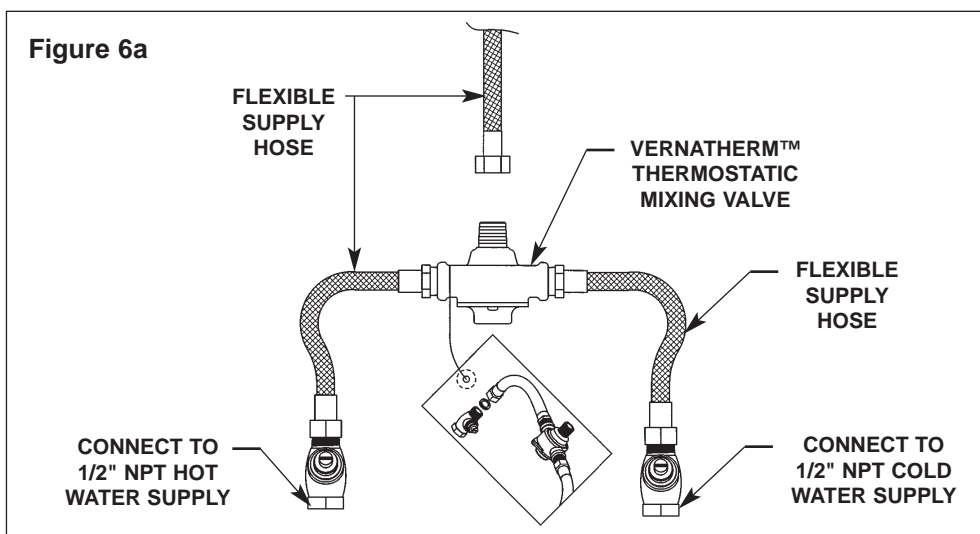

Installation Instructions *continued . . .*

Step 5: Connecting electrical and supply tubing

⚠ WARNING: The Express® must be connected to the 24 VAC Class II plug-in transformer provided. Connection to 110 VAC can result in damage to the electronics and cause personal injury.

⚠ CAUTION: Connection of leads other than shown may cause permanent damage to the sensor.

1. Snap the sensor circuit plug from the sprayhead into the solenoid circuit plug located on the valve bracket.
2. Snap the transformer circuit plug into the female transformer circuit plug located on the valve bracket.
3. Insert the two sprayhead supply tubes into the two solenoid tube connectors by loosening the compression nut and firmly pushing the tubing into the tube connector until the tubes are fully seated, then re-tighten the compression nut (hand-tight and then two full turns with a wrench) (see Figure 8).

Step 6: Completing installation

1. Turn on the water supply to the Express® and check for leaks.
2. Turn on the electrical power to the electrical outlet and pass your hand in front of each station's sensor until all the air is purged from the lines and water is flowing smoothly.
3. After testing is complete, reinstall panel to frame. Fasten panel with eight Torx-head screws provided (see Figure 3 on page 8).

Note: For Express® units with optional soap dispensers, see pages 12 and 13 for soap dispenser maintenance instructions.

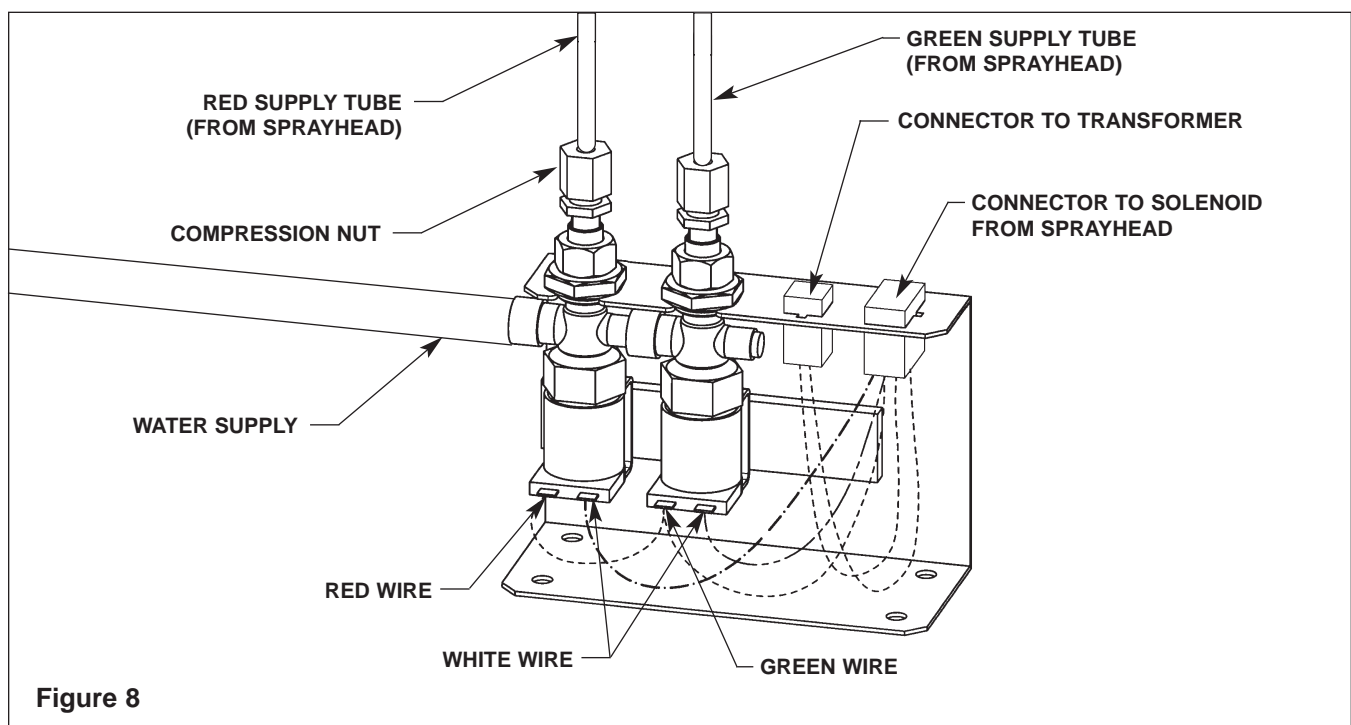

Cleaning and Maintenance Instructions



IMPORTANT: Strong alkaline or acid-based chemicals and cleansers should not be used to clean Terreon®. If these chemicals come in contact with the Terreon® surface, wipe off the surface immediately and flush with soapy water.

Terreon® and panel maintenance

The bowl and sprayhead cover are constructed of Terreon®, a densified solid surface material composed of an acrylic modified polyester resin. Terreon® is resistant to chemicals, stains, burns and impact. Surface damage can be easily repaired with everyday cleaners or fine grit abrasives. The panel and sprayhead body are made of an acrylic/ABS laminate, and will not chip, peel or flake. With regular cleaning, your Terreon® fixture will provide years of dependable service.

Cleaning

- **Daily Cleaning:** Wipe the surface with a damp cloth and wipe dry.
- **Weekly Cleaning:** Wipe the surface with a damp cloth and a household liquid detergent. Stubborn stains can be removed as follows:
 1. Using a #7448 Scotch-Brite® pad, scrub with an abrasive cleanser such as Ajax®, Comet® or Soft Scrub® and water.
 2. Clean thoroughly with soapy water and allow to dry.
- **Scorch Marks:** Although Terreon® will not burn, a lit cigarette in contact with Terreon® could leave a scorch mark. Scorch marks can be removed by buffing with a #7448 Scotch-Brite pad or with an abrasive cleaner.
- **Repair kit:** In the unlikely event your Terreon® surface becomes damaged, it can easily and inexpensively be repaired. Contact your Bradley representative to order a repair kit and be sure to specify color when ordering.

Panel cleaning



IMPORTANT: Do not use abrasive cleansers to clean the panel or sprayhead body. Abrasive cleaners can mar the surface.

- **Graffiti/Vandalism:** If vandals create markings on the panel, Bradley recommends using Motsenbocker's LIFT OFF® to remove ink and spray paint. Remover #3 is for ink and markers, and Remover #4 is for spray paint. Motsenbocker's LIFT OFF® can be ordered through Sanitary Maintenance Service Inc. (call 1-800-451-5523 x 425 or visit www.sanitarymaintenance.com/product.htm for ordering information). After cleaning with LIFT OFF®, give the panel a final thorough cleaning with a liquid tub and tile cleaner to remove soil and maintain the glossy finish.

NOTE: Use of brand names is intended only to indicate a type of cleaner. This does not constitute an endorsement, nor does the omission of any brand name cleaner imply its inadequacy. Many products named are regional in distribution and can be found in local supermarkets, department and hardware stores or through your cleaning service. It is emphasized that all products should be used in strict accordance with package instructions.

Soap Dispenser Maintenance

Step 1: Fill soap dispensers

The two soap valves will dispense vegetable/coconut oil liquid soaps, synthetic detergents, viscous lotion soaps, and antiseptic solutions. A 10-15% concentration is recommended for vegetable or coconut oil liquid soaps. Synthetic detergents, lotion soaps, and antiseptic soaps require no dilution.

1. Using two screwdrivers (or similar tool), push up on the release tabs located beneath each soap dispenser and pull out the soap tanks from the sprayhead (see Figure 9a).
2. To remove packing dust, rinse out each soap tank with hot water. Shake water out thoroughly and allow to dry.
3. Pour the soap into each soap tank's filler hole (see Figure 9b).
4. After each soap tank is filled, position the soap tanks into the sprayhead openings and push into place.

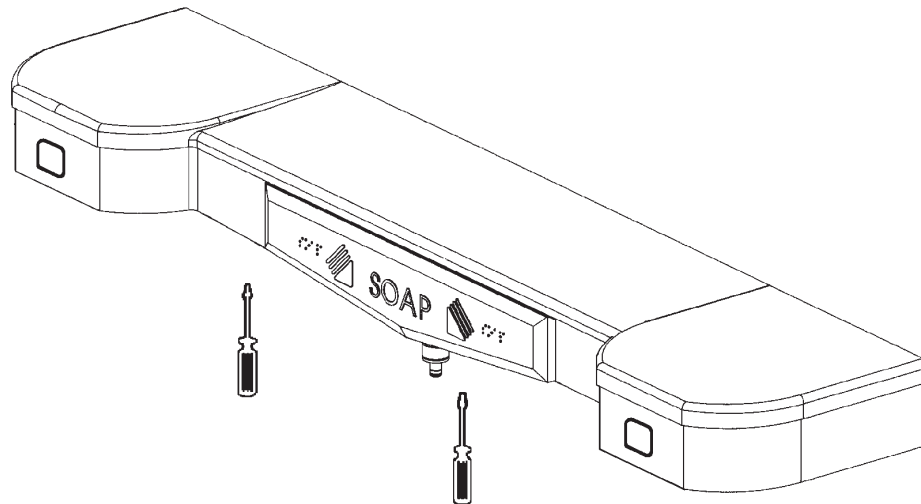

Figure 9a

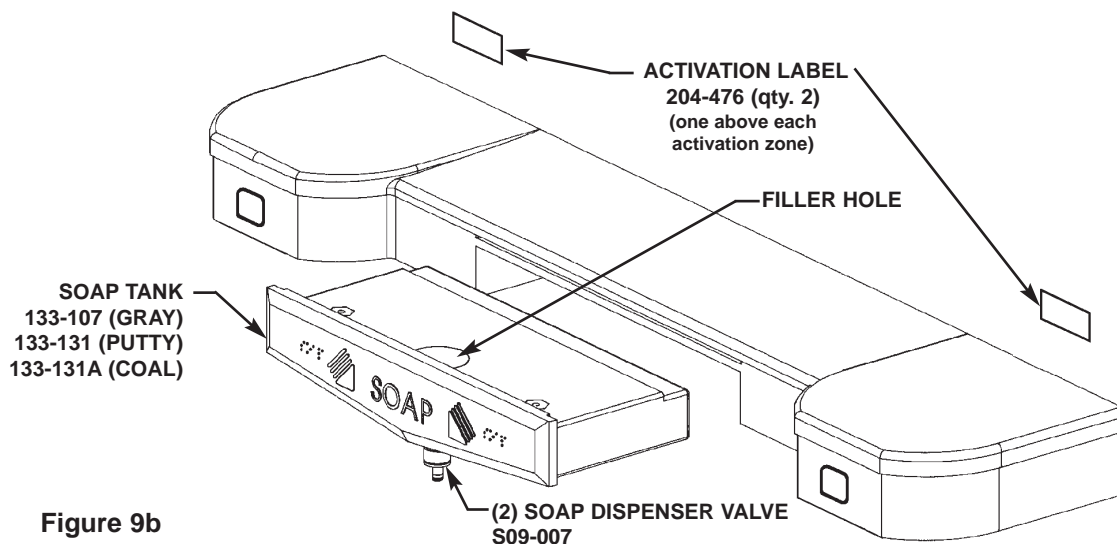

Figure 9b

Soap Dispenser Maintenance *continued* . . .

Step 2: Change soap type

1. Pour out all of the soap from the dispenser.
2. Rinse the soap dispenser with hot water several times until all of the residue is removed, and pump the valve until clean water appears.
3. Rinse the dispenser with ethyl alcohol and allow to air dry.
4. After the dispenser is dry, pour the new soap into the soap dispenser.

Step 3: Cleaning Instructions

Regular cleaning of the soap dispenser is recommended to ensure optimum performance and maximum service life. Cleaning the soap dispenser monthly to remove soap residue, dirt, and other accumulations should become a regular part of your washroom cleaning routine and general maintenance program.



IMPORTANT: Do not use abrasive cleansers to clean the soap tank. Abrasive cleansers can mar the surface.

Clean exterior: Use warm water and soap to clean the exterior of the soap dispenser. Dry with a soft cloth.

Clean interior: Inspect the interior of the soap tank for residue or coagulation of soap. If necessary, clean the soap tank according to the following procedure:

1. Pour out any remaining soap in the tank.
2. Fill the tank half-full of hot water and shake the tank to dislodge the soap residue.
3. Empty the water from the container and repeat steps 1 and 2 until the soap container is clean.

NOTE: If rinsing alone does not remove the soap residue, place a small chain (24 inches long) into the soap tank with hot water and shake the container until the chain dislodges the residue. Then remove the chain and rinse out the soap tank.

Clean internal components: To clean the internal components of the soap dispenser, pump hot water through the soap dispenser until a clean flow of water comes out of the valve.

Assembly of Components

Paneling

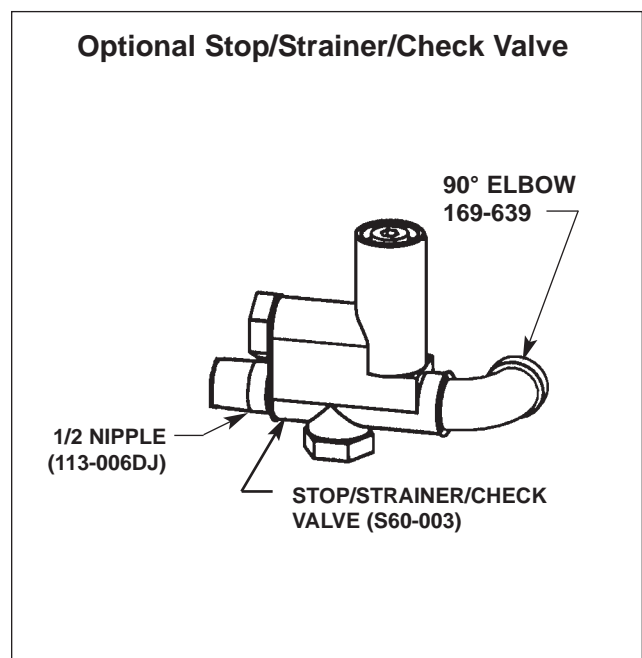
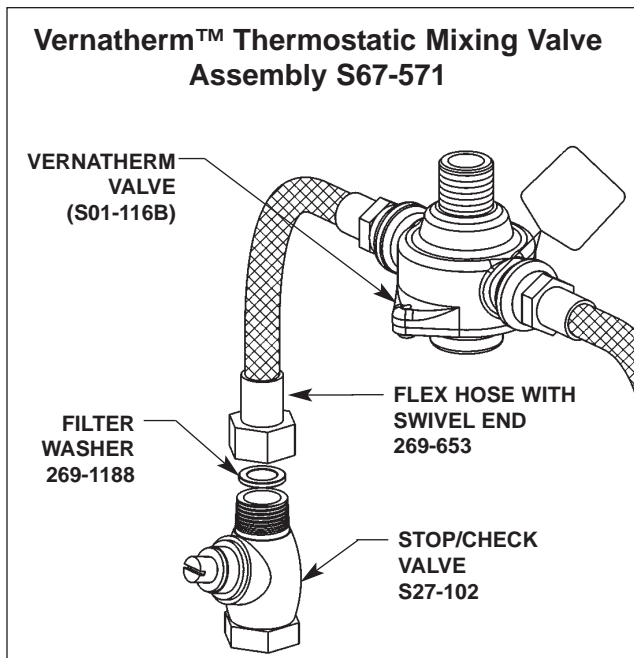
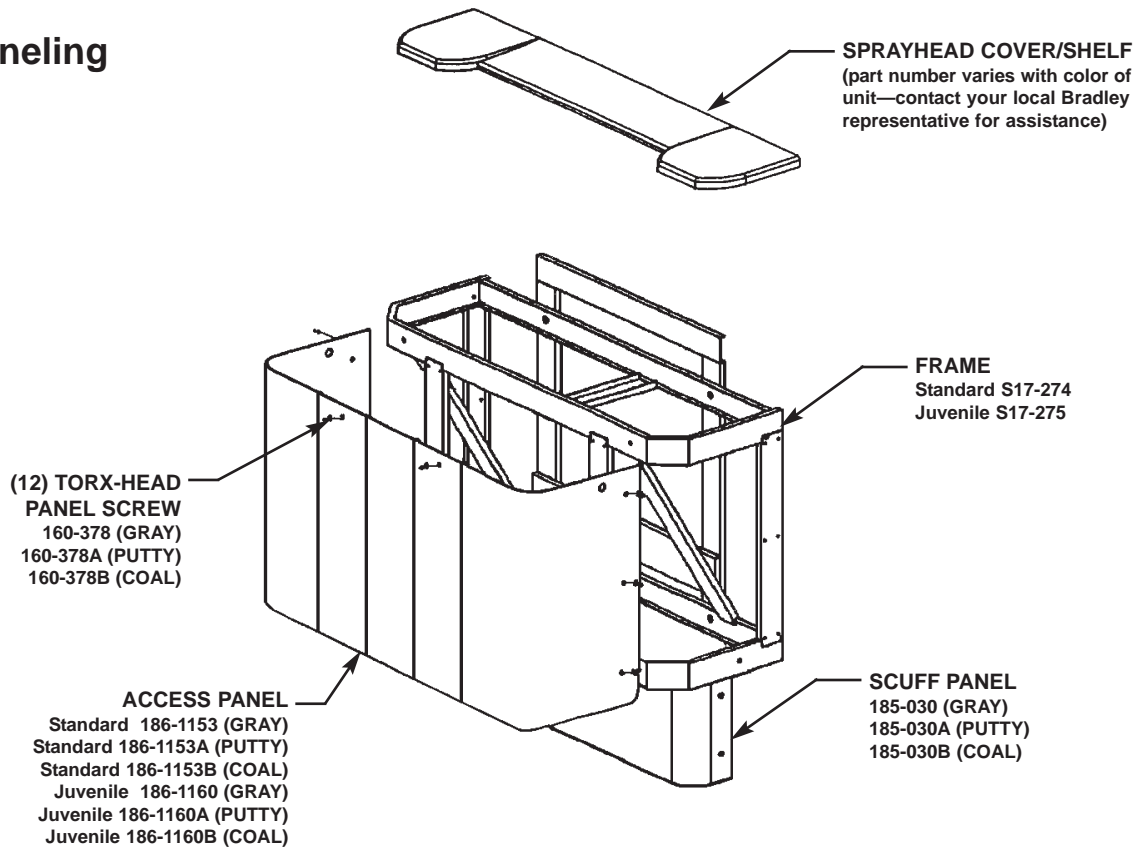

Assembly of Components *continued* . . .

Sensor assembly and solenoid valve

To access solenoids and sensors: Remove the eight Phillips-head screws located in the bottom of the sprayhead body and lift the cover/shelf off.

To re-install sprayhead cover/shelf: Position the cover/shelf on the sprayhead body and secure it to the sprayhead body using the eight screws provided.

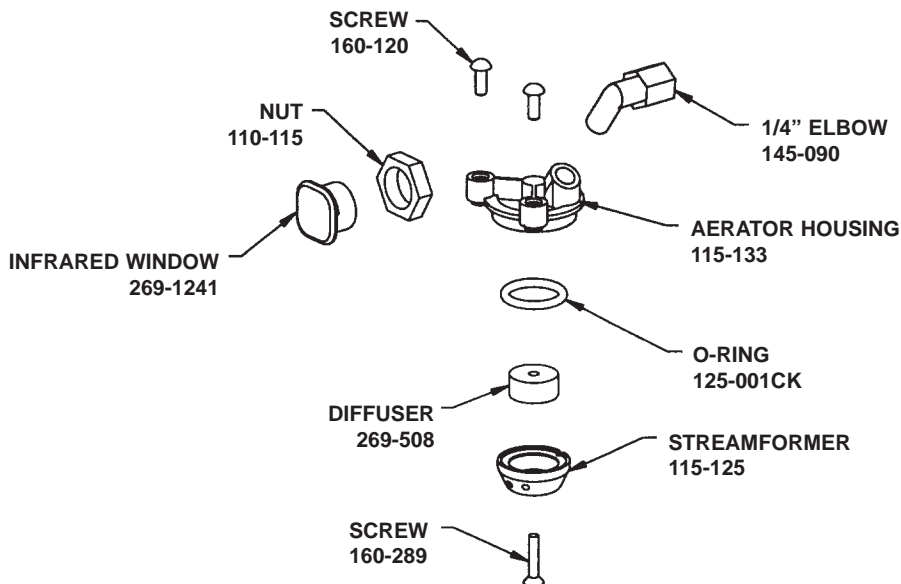

Other Replacement Parts

BOWL MOUNTING HARDWARE

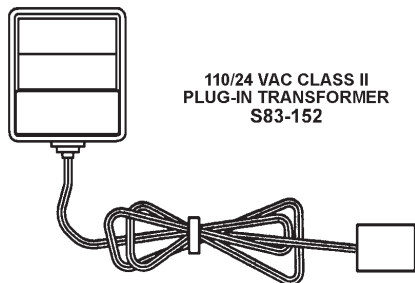
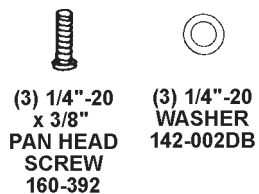

DRAIN ASSEMBLY

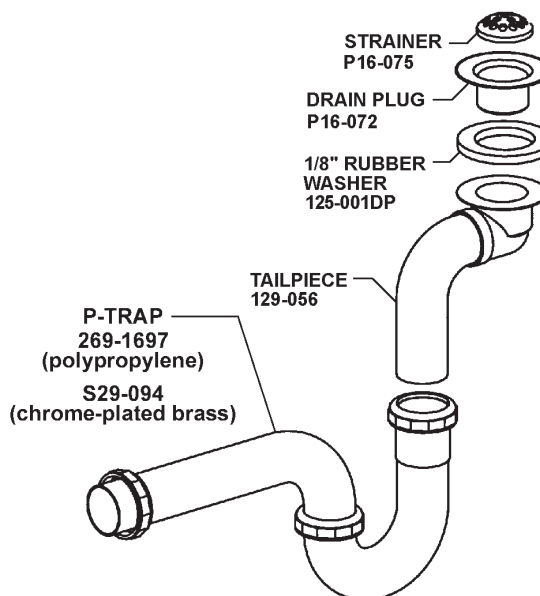

Check Valve Troubleshooting

If water just dribbles or does not flow from sprayhead:

1. Close the stops and check the valves that supply water to the lavatory system.
2. Inspect the stop/check valves for proper installation.
3. Remove the flexible hoses from the stop/check valves and clean the strainers, if necessary.

If water sprayhead delivers all hot or cold water:

1. Close the stops and check the valves that supply water to the lavatory system.
2. Inspect the stop/check valves for proper installation.
3. Remove the flexible hoses from the stop/check valves and clean the strainers, if necessary.
4. Inspect mixing valve for proper installation (see Vernatherm valve on page 19).
 - A red marking indicates the hot inlet.

Solenoid Valve Troubleshooting



CAUTION: Turn off electrical and water supplies to unit before troubleshooting.

Problem: An individual operating station fails to shut off and drips.

Cause: There is debris trapped between the diaphragm and the valve seat.

Solution: Remove debris between diaphragm and the valve seat.

1. Using a small wrench, loosen the bonnet nut, unscrewing counterclockwise, and gently tip forward to remove from the valve body. Be careful not to lose the armature or spring.
2. Remove the diaphragm. Remove any particles that have been trapped between the diaphragm and the valve seat. Rinse off the diaphragm and inspect for damage. Make sure both orifices are open.
3. Reassemble in reverse order. Do not overtighten the bonnet nut or you may crack the plastic valve body. Hand tight plus 1/8 turn is sufficient.
4. Reconnect the wiring per diagram on page 14.

Problem: An individual operating station fails to turn on.

Cause: A failed coil for the valve, or loose electrical connection to the terminal.

Solution: Test the station to determine cause.

1. Disconnect the wires from the coil (269-579) of an adjacent valve. Disconnect the wires from the problem valve and reconnect to the adjacent valve.
2. Turn on electrical and water supplies to the unit. Pass your hand in front of the sensor of the problem station, and the adjacent station should operate.

If the adjacent station operates and cycles normally, replace the coil on the problem valve.

If the adjacent valve fails to turn on, inspect the wires from the sensor cable and do the following:

- make sure there are no breaks and that the fully insulated disconnect terminals are firmly crimped in place;
- turn off electrical and water supplies;
- reconnect to the adjacent valve and turn on electrical and water supplies to the unit;
- pass your hand in front of the sensor. If the station still fails to turn on, replace the sensor (see page 16).

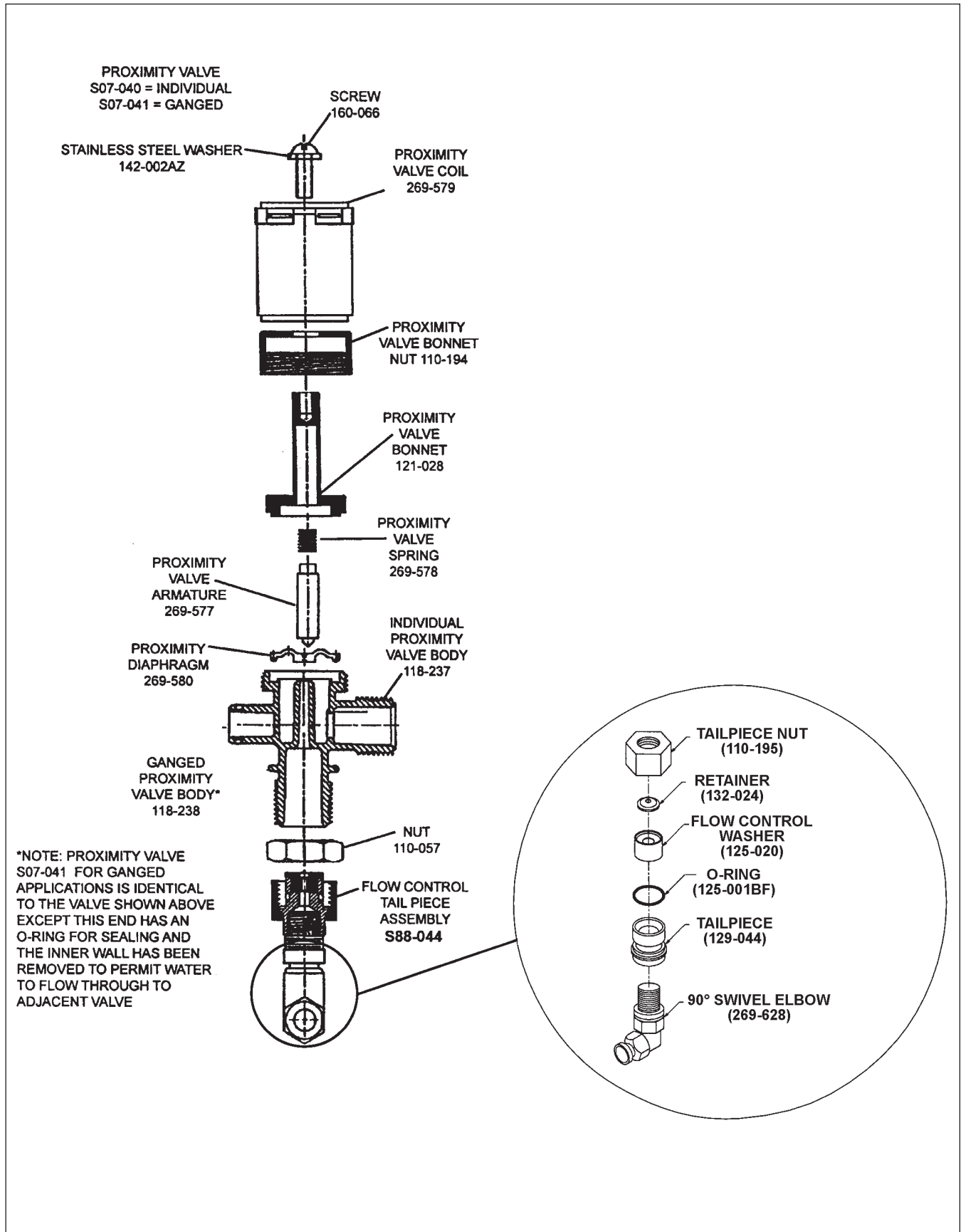

Vernatherm™ Mixing Valve Maintenance and Service

*Repair kit S45-049 is pre-packaged and includes O-Ring, Flip Ring, Power Element and Spring.

Maintenance Instructions

1. Disassemble the Vernatherm™ Valve as shown, being careful not to damage the power element. Replace the element, if necessary.
2. If necessary, remove the old flip ring and replace with a new ring.

NOTE: An old or worn flip ring may cause temperature fluctuation and/or water chatter.

3. Reassemble the power element and valve body. Apply grease to the main valve slide and gently ease into position, rotating so that grease is applied to the flip ring. Do not force the slide as this may push the flip ring from its position. To test, rotate the slide; a slight drag should be felt when correctly installed.
4. Reassemble the valve.

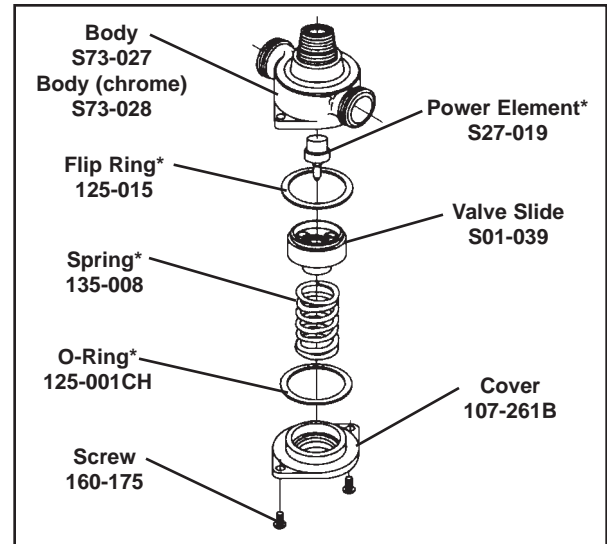

Service Suggestions

When servicing the valve, make sure it is installed in the correct position. The most common error occurs when the valve is installed in the reversed position, that is, the hot line is connected to the cold line and the cold is connected to the hot.

NOTE: A red marking indicates the hot side of the valve.

The table below lists conditions that occur when the valve is installed correctly, and when it is in the reversed position.

IF			THEN
Valve Position is	Hot Supply	Cold Supply	Valve Delivers
Correct	Hot	Cold	Mixed 107°
Correct	Hot	No Water	Valve shuts off or drips
Correct	No Water	Cold	Valve shuts off or drips
Correct	Hot	Hot	Hot
Correct	Cold	Cold	Cold
Reversed	Hot	Cold	Cold/below 107° Hot/above 107°
Reversed	Hot	No Water	Hot
Reversed	No Water	Cold	Cold
Reversed	Hot	Hot	Hot
Reversed	Cold	Cold	Cold