

Installation

TCS Series

Terreon® Lav Decks

Table of Contents

Supplies Required By Installer	2
Installation	2
Dimensions - Mounting	3
Dimensions - Soap Dispenser	3
Dimensions - Drinking Fountains	4
Dimensions - Faucets.....	5
Cleaning and Maintenance for Terreon®.....	6

WARNING

Make sure that all water supply lines have been flushed and then completely turned off before beginning installation. Debris in supply lines can cause valves to malfunction.

Turn OFF electrical power to the electrical outlets, then unplug all electrical units prior to installation. Electrical power MUST remain off until installation is complete. After installation is complete, turn on the water supply first, then turn on the electrical power.

Installer's hardware must be appropriate for wall construction. Wall anchors must have a minimum pull-out rating of 1,000 pounds.

IMPORTANT

Read this entire installation manual to ensure proper installation. When finished with the installation, file this manual with the owner or maintenance department. Compliance and conformity to local codes and ordinances is the responsibility of the installer. Product warranties may be found under "Products" on our website at www.bradleycorp.com.

Separate parts from packaging and make sure all parts are accounted for before discarding any packaging material. If any parts are missing, do not begin installation until you obtain the missing parts.

For standard height mounting, do not exceed the recommended 34" distance from the top of the lav deck to the finished floor. To meet ADA requirements, the lav deck cannot exceed the 34" maximum height dimension.



Supplies Required

- 1/2" Nominal copper tubing for hot and cold supply
- 1-1/2" NPT drain piping
- Adhesive Caulk/Sealant to secure classroom sink to cabinetry
- Silicone caulk



Installation

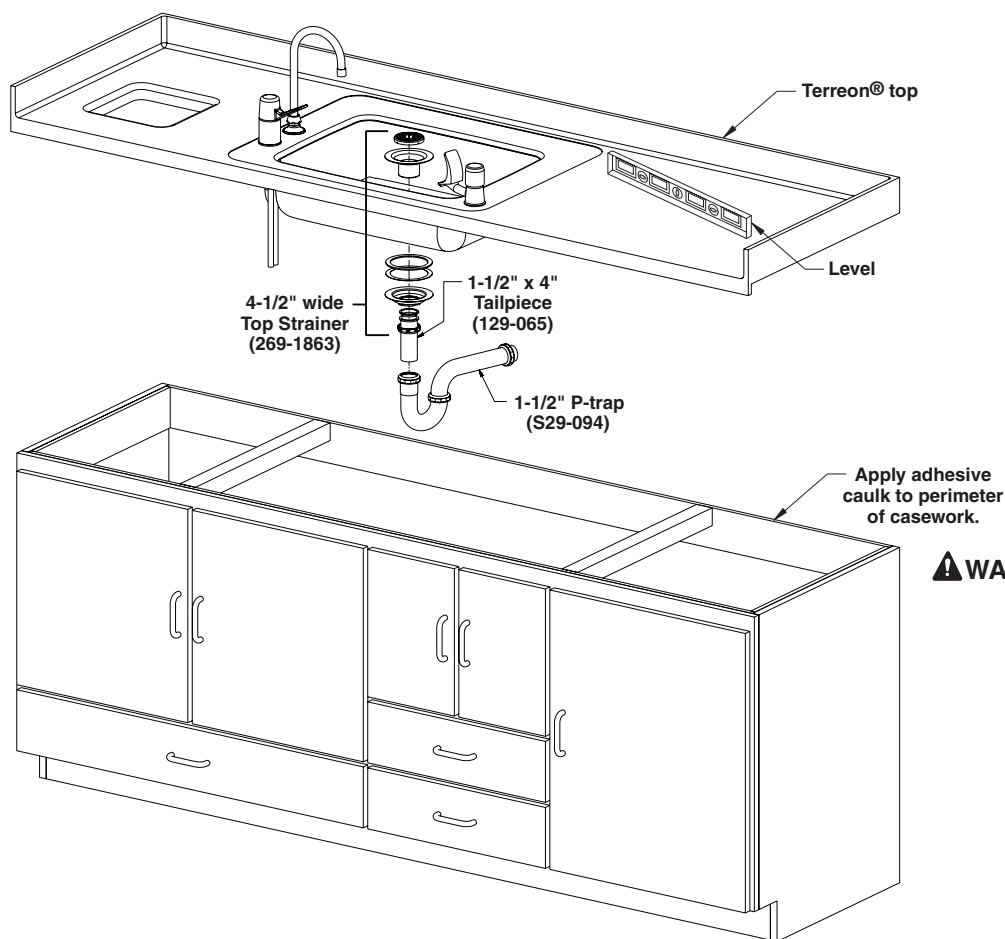

⚠ WARNING The Sink and Deck should be supported properly by casework. The maximum span of unsupported deck should be no greater than 36". If casework does not meet this requirement, add appropriate support such as 1" x 2". Apply silicone caulk to hide seams as needed.

Wall Mounting Bracket Option

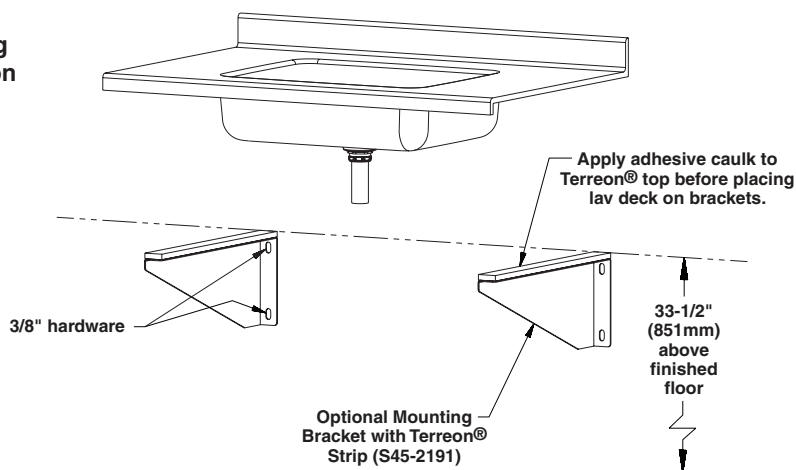

Terreon Lav Deck-TCS Series Dimensions



All dimensions are reference and subject to change.

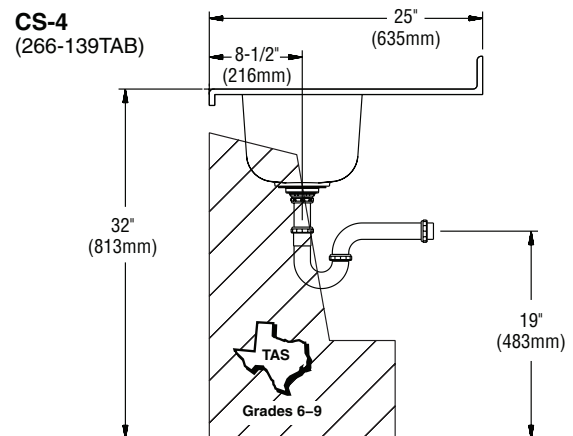
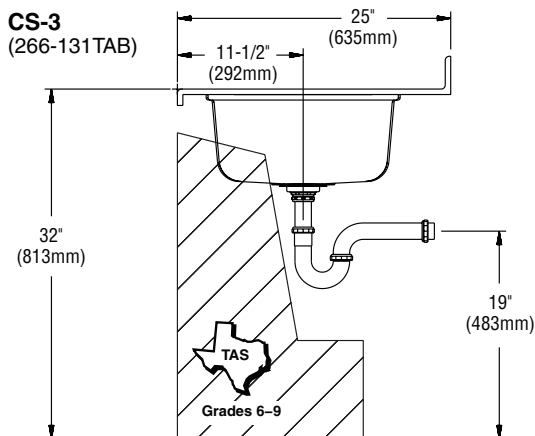
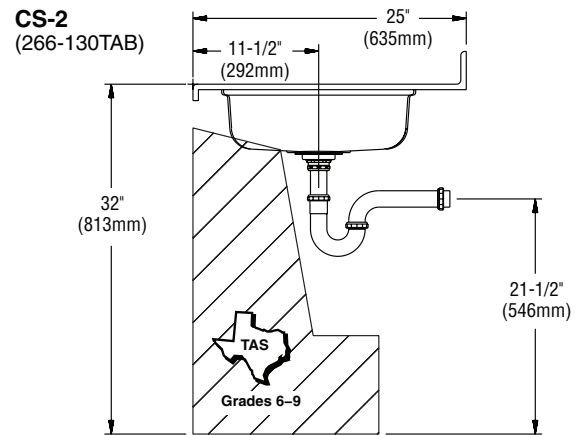
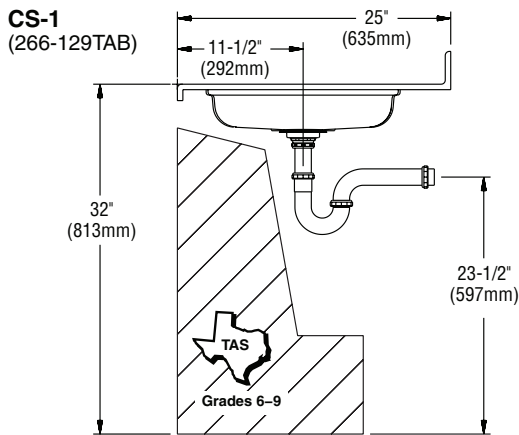

Terreon® Lav Deck-TCS Series Soap Dispenser Dimensions

Model 6324

DIMENSIONS			
Model	A	B	Capacity
6324	7-1/8" (181mm)	2-1/2" (64mm)	16 oz.
6324-68	8-15/16" (227mm)	3-1/4" (83mm)	32 oz.

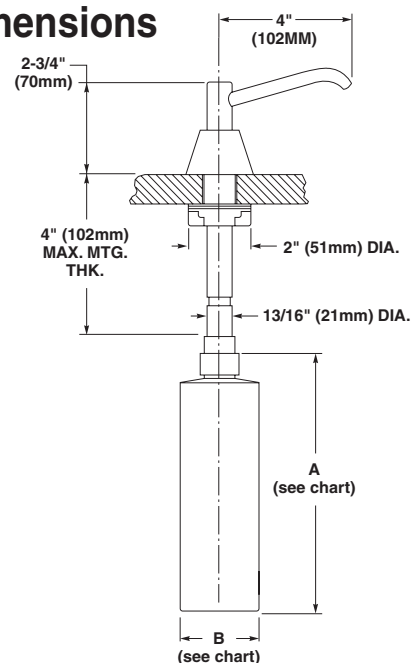

Terreon Lav Deck-TCS Series Drinking Fountain Dimensions

Drinking Fountain/Bubbler—Push Button Activation

Part Number 269-1624

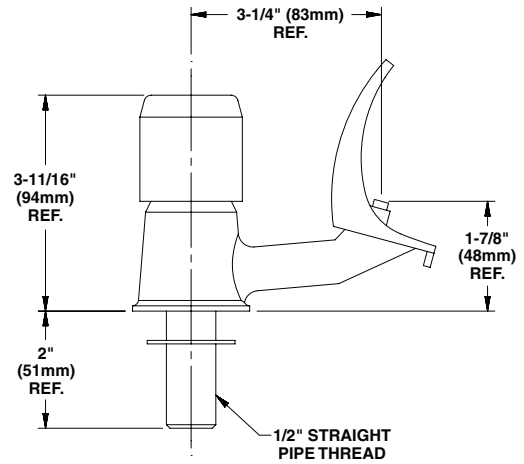
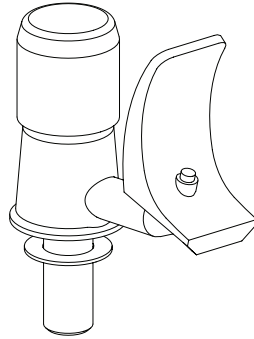

Drinking Fountain Positioning

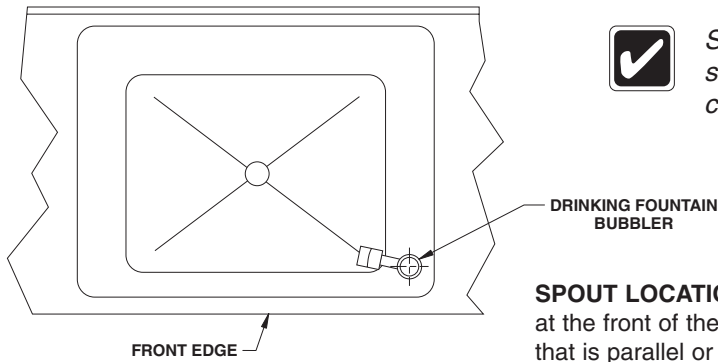

Some state and local codes require separate sinks for faucets and drinking fountains. Always check local codes and ordinances for compliance.

SPOUT LOCATION TO MEET USAF: The spout must be positioned at the front of the unit and shall direct the water flow in a trajectory that is parallel or nearly parallel to the front of the unit.

Terreon Lav Deck-TCS Series Faucet Dimensions

Wristblade Handles – Gooseneck Faucet

Part Number 269-878

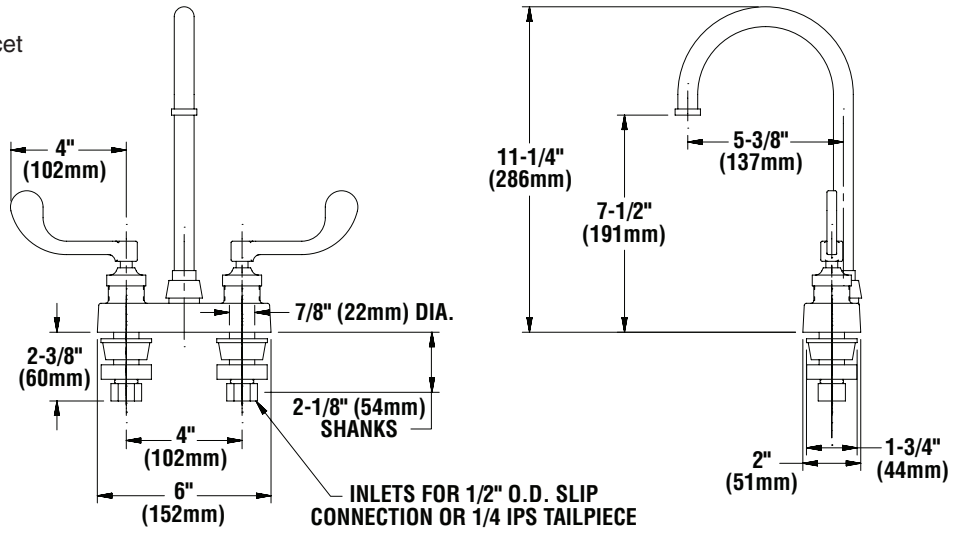

Model IR – Gooseneck Faucet

Part Number S53-327

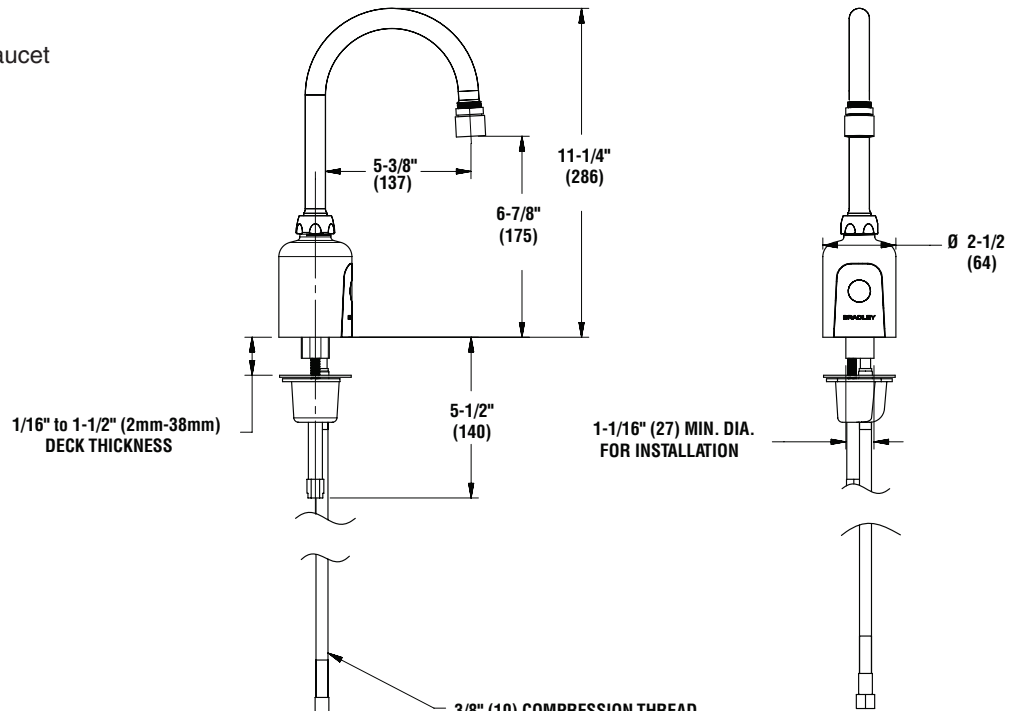

Cleaning and Maintenance for Terreon®

Material Description: Terreon is an NAHB-certified densified solid surface material composed of polyester resin and is resistant to chemicals, stains, burns and impact. Surface damage can be easily repaired with everyday cleansers or fine grit abrasives.

Routine Cleaning: Clean daily or as often as conditions require using a standard commercial or household cleaner such as Formula 409® or Windex®.

Stubborn Stains: Remove tough stains with Ajax®, Comet®, or Soft-Scrub® and a green Scotch-Brite® pad or lightly sand in a circular motion with 240 grit wet/dry sandpaper. The finish can be renewed with a maroon Scotch-Brite pad.

Special Situations for Terreon Material

Scratches: Remove scratches with a green Scotch-Brite pad. The finish can then be renewed with a maroon Scotch-Brite pad, followed by a white Scotch-Brite pad or 30-micron sandpaper.

Hard Water Deposits: Remove hard water deposits with a mild solution of vinegar and water. Always rinse the unit thoroughly after cleaning.

Restoring the surface: Use Hope's® Solid Surface cleaner and polish to refresh and protect the Terreon Solid Surface material. Bradley recommends additional care and maintenance for the darker colored Terreon. For complete instructions on this additional maintenance, visit bradleycorp.com.

NOTICE! Do not use strong acid or alkaline chemicals and cleansers to clean Terreon. If these chemicals come in contact with the surface, wipe them off immediately and rinse with soapy water. Avoid contact with harsh chemicals such as paint remover, bleach, acetone, etc. Avoid contact with hot pans and objects.

Repair Kits: Terreon repair kits are available. Contact your Bradley representative or distributor for part numbers and pricing. Repair kits are made to order and have a shelf life of 30 days.



Terreon® is a unique, cast solid surface material. Aggregate flow and distribution as well as shades of color can vary from product to product creating natural characteristics.

Brand Names

Use of brand names is intended only to indicate a type of cleaner. This does not constitute an endorsement, nor does the omission of any brand name cleaner imply inadequacy. Many products named are regional in distribution, and can be found in local supermarkets, department and hardware stores, or through your cleaning service. It is emphasized that all products should be used in strict accordance with package instructions.