

# Installation and Maintenance Instructions

## Bradley Terreon® Splashes and Aprons

### Terreon® Warranty

Bradley Corporation warrants to commercial and institutional purchasers only each unit free from defects in material and workmanship under normal use and service upon the following terms and conditions.

1. This warranty is limited to replacing or repairing, at our option, transportation charges prepaid by the purchaser, any Bradley unit or part thereof which our inspection shall show to have been defective within the limitations of this warranty.
2. The period during which Terreon® components are warranted for five (5) years.
3. This warranty does not cover installation or any other labor charges and does not apply to any units which have been damaged by accident, abuse, improper installation or improper maintenance.
4. The replacement or repair of defective units as stated in this warranty shall constitute the sole remedy of the purchaser and the sole liability of Bradley Corporation under this warranty. Bradley Corporation shall not otherwise be liable under any indirect damages caused by defects in the repair or replacement thereof.
5. This warranty extends only to commercial and institutional purchaser and does not extend to any others, including consumer customers of commercial institutional purchasers.
6. This warranty is in lieu of all other warranties, expressed or implied, including any implied warranty of merchants ability or fitness for a particular purpose or otherwise.

## Pre-Installation Information

### Terreon® Material

Splashes and Aprons are constructed of Terreon®, a densified solid surface material composed of an acrylic modified polyester resin. Terreon® is resistant to chemicals, stains, burns and impact. Surface damage can be easily repaired with everyday cleaners or fine grit abrasives.

### Supplies Required:

- Silicone Caulk/Sealant
- Alcohol to clean mating Terreon® surfaces
- Liquid Nails® or equivalent adhesive

## Installation Instructions

### Step 1a: Mounting Side and Back Splashes

1. Determine measurements and trim Terreon® to fit as needed.
2. Clean the mating surfaces with alcohol.
3. Apply silicone caulk/sealant to the back of the Side or Backsplash and adhere to the mating surface (see Figure 1a).
4. Remove excess sealant.
5. Caulk the seams as needed.

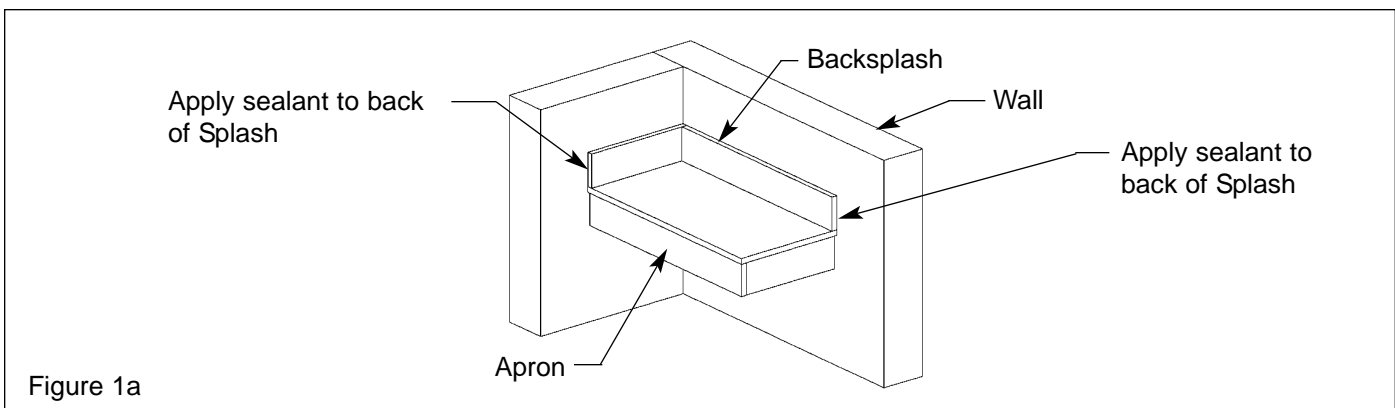

### Step 1b: Mounting Front or Side Aprons

1. Determine measurements and trim the Terreon® to fit as needed.
2. Clean the mating surfaces with alcohol.
3. Apply Liquid Nails or equivalent adhesive to the mating surfaces (see Figure 1b).
4. Clamp Apron to the deck every 4"-6" minimum.
5. Remove excess adhesive.
6. Remove the clamps after approximately 1 hour.

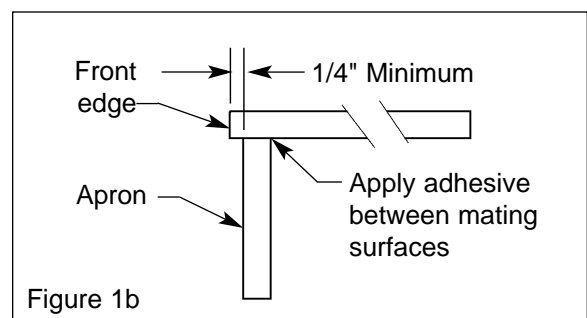

## Maintenance Instructions

- ⚠ IMPORTANT:** Strong alkaline or acid-based chemicals and cleansers should not be used to clean Terreon®. If these chemicals come in contact with the Terreon® surface, wipe off the surface immediately and flush with soapy water.

### Terreon® Maintenance

Splashes and Aprons are constructed of Terreon®, a densified solid-surface material composed of an acrylic modified polyester resin. Terreon® is resistant to chemicals, stains, burns and impact. Surface damage can be easily repaired with everyday cleaners or fine-grit abrasives. With regular cleaning, your Terreon® fixture will provide years of dependable service.

### Cleaning

- **Daily cleaning:** Wipe the surface with a damp cloth, then wipe dry.
- **Weekly cleaning:** Wipe the surface with a damp cloth and a household liquid detergent. Stubborn stains can be removed as follows:
  1. Using a #7448 Scotch-Brite® pad, scrub with an abrasive cleanser and water.
  2. Clean thoroughly with soapy water.
  3. Allow to dry.
- **Scorch marks:** Although Terreon® will not burn, a lit cigarette in contact with Terreon® could leave a scorch mark. Scorch marks can be removed by buffing with a #7448 Scotch-Brite™ pad or scrubbing with an abrasive cleanser.
- **Repair kit:** In the unlikely event your Terreon® surface becomes damaged, it can easily and inexpensively be repaired. Contact your Bradley representative to order a repair kit and be sure to specify color when ordering.

*NOTE: Use of brand names is only intended to indicate a type of cleaner. This does not constitute an endorsement, nor does the omission of any brand name cleaner imply its inadequacy. Many products named are regional in distribution and can be found in local supermarkets, department and hardware stores or through your cleaning service. It is emphasized that all products should be used in strict accordance with package instructions.*