

Installation

MF2922/AST4

Terreon® Corner-Fount™ Washfountain with Air Valve

(Standard, Juvenile and OBC Height)

Table of Contents

Pre-Installation Information	2
Parts Included with the Corner-Fount™	3
Installation Instructions	4-8
Cleaning and Maintenance	9-11
Troubleshooting	12-14

IMPORTANT!

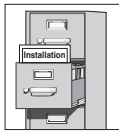

Read this entire installation manual to ensure proper installation. When finished with the installation, file this manual with the owner or maintenance department.



Separate parts from packaging and make sure all parts are accounted for before discarding any packaging material. If any parts are missing, do not begin installation until you obtain the missing parts.

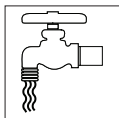

Make sure that all water supply lines have been flushed and then completely turned off before beginning installation. Debris in supply lines can cause valves to malfunction.

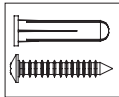

Hardware supplied by installer must be appropriate for wall construction. Wall anchors used must have a minimum pull-out rating of 1,000 lbs.



Product warranties may be found under “Product Information” on our web site at www.bradleycorp.com.

Supplies Required by Installer

- (2) 3/8" diameter bolts with washers and (2) wall anchors appropriate for your installation
- (2) 3/8" diameter bolts with washers and (2) floor anchors appropriate for your installation
- 1/2" nominal copper tubing for hot and cold water supply lines
- 1-1/2" NPT drain trap and waste connection
- Pipe sealant and plumber's putty

Pre-Installation Information

Terreon Material

The Corner-Fount is constructed of Terreon, a densified solid surface material composed of polyester resin. Terreon is resistant to chemicals, stains, burns and impact. Surface damage can be easily repaired with everyday cleaners or fine-grit abrasives. Terreon is NAHB certified to meet ANSI Z124.3, Z124.6 and ANSI/ICPA SS-1-2001.

Push Button and Metering Valve

Each nozzle is controlled by a separate push button and a separate metering valve, so each user activates a single metered flow of water pre-blended to a specific temperature. Each valve uses less than half the maximum amount of hot water allowed by the ANSI/ASHRAE/IES 90A-1980 Standard.

Parts included with the Corner-Fount™

Separate all parts from packaging materials and ensure you have all the parts required for assembly. If any parts are missing, do not attempt to assemble the Bradley Terreon® Corner-Fount™ Washfountain until you obtain all parts.

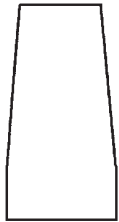

FRONT PANEL



MOUNTING PANELS



PEDESTAL PANEL (LEFT)



PEDESTAL PANEL (RIGHT)



THREADED ROD (2)
WING NUTS (2)
AND WASHERS (2)

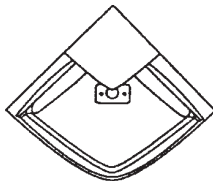

BOWL



COVER



(2) 1/8" PLASTIC TUBING
3' LONG



(2) 1/4" PLASTIC TUBING
3' LONG

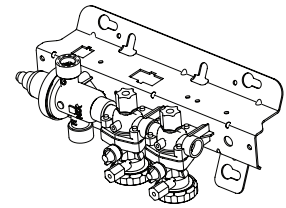

Metering Valve Assembly

Pedestal Prepack S45-797A

(8) SCREW

UPPER BRACKET

(4) 5/16" I.D. WASHER

LOWER BRACKET

Hose-Stop Prepack - TMA S45-2730

Hose

Stop

Hose-Stop Prepack - TL S45-2731 (optional)

Hose

Stop

PREPACK S45-1283

(2) 3/8"-16 x 1-1/2" HEX HEAD BOLT

STRAINER

DRAIN SPUD

(2) 3/8"-16 HEX NUT

(2) 5/16" I.D. WASHER

(2) 13/32" I.D. PLAIN WASHER

(2) 10-24 x 1/2" FLAT SOCKET HEAD SCREW

(2) 1/4"-20 x 1/2" PAN HEAD SCREW

(2) ANCHOR PLATE

(2) WALL BRACKET

(2) 3/8" I.D. LOCK WASHER

1 Rough-Ins

A Rough in 1/2" nominal copper tubing for hot and cold supply lines through wall or floor at dimensions shown.

B Rough in 1-1/2" NPT drain waste connection through wall or floor at dimensions shown.

 Flush the supply lines before making connections. Debris in supply lines will cause the valves to malfunction.

 Wall anchors need to withstand 1000 lbs. pull force.

 Compliance and conformity to local codes and ordinances is the responsibility of the installer.

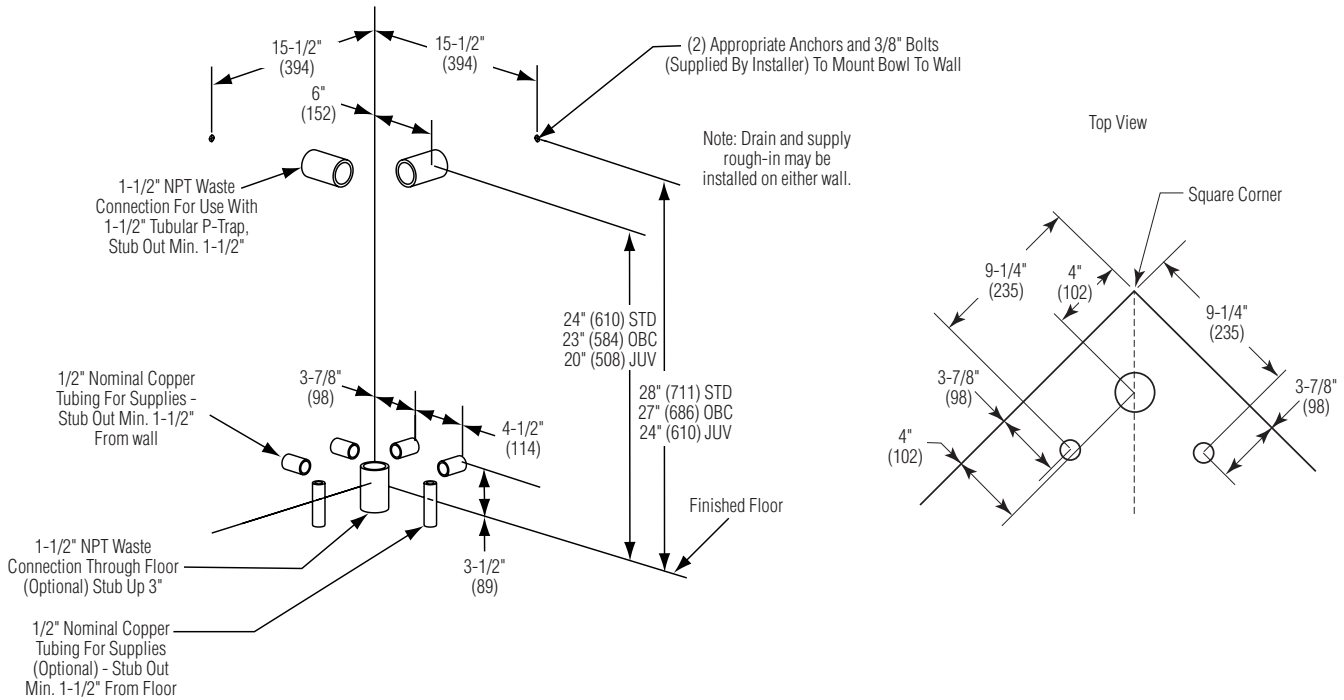

2 Assemble Pedestal



Washers are not utilized on back of mounting panels.

A Fasten the mounting panels to the pedestal with four pan head 1/4"- 20 x 1/2" screws supplied.

B Install the upper and lower brackets to the pedestal panels with two pan head 1/4"- 20 x 1/2" screws and 5/16" I.D washers supplied.

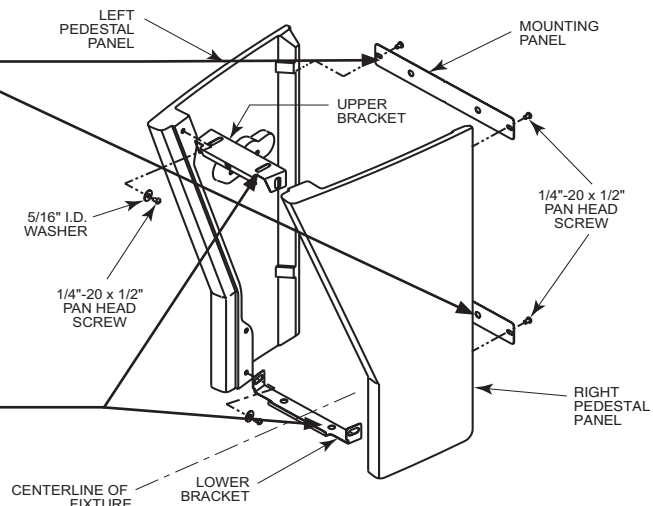

3 Install Pedestal

 Remove molding strips or tiles which could prevent a flush mounting to the wall.



A Measure and mark the centerline of the washfountain on the wall and floor.

B Before mounting the pedestal to the floor, make sure the floor is level. If it is not level, be prepared to install shims when positioning the pedestal in Step C.

C With someone to assist you, move the pedestal assembly to the wall using appropriate lifting procedures, and align the locating notches on the mounting panel with the centerline marked on the wall. If the floor is not level, install shims under the left and/or right pedestal.

D Drill holes in the floor through the two 1/2" diameter holes in the lower bracket and install two anchors (supplied by installer) for 3/8" bolts.

E After floor anchors are installed, secure the pedestal assembly to the floor anchors using two 3/8" bolts and washers (supplied by installer).

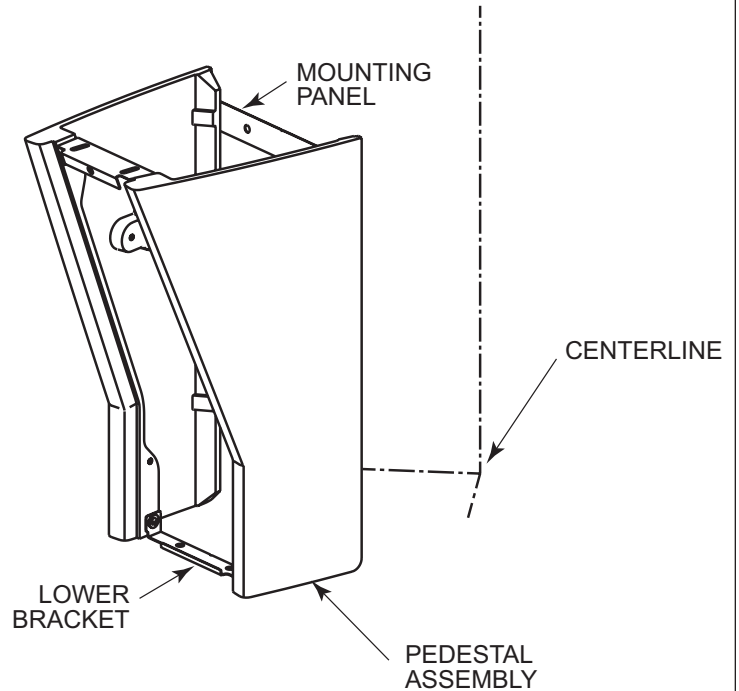

4 Install Valve Assembly

 The letter "H" on the Navigator® mixing valve indicates hot water supply inlet.

A Attach the stops to hot and cold water rough-ins.

B Connect one end of each supply hose to the stops.

C Inside the pedestal, install the two 1/4" - 20 x 1/2" screws (supplied with valve assembly) in the mounting holes on the side of the left pedestal panel. Do not thread the screw completely into the panel, but allow 5/16" of the screw to be exposed.

D Connect the other end of each supply hose to the Navigator® TMV valve assembly (one on the hot side, one of the cold side).

E Mount the valve bracket to the left side of the pedestal.

F For optional single tempered supply: attach the stop to the 1/2" tempered supply line. Connect the stop to the valve assembly with the flexible supply hose.

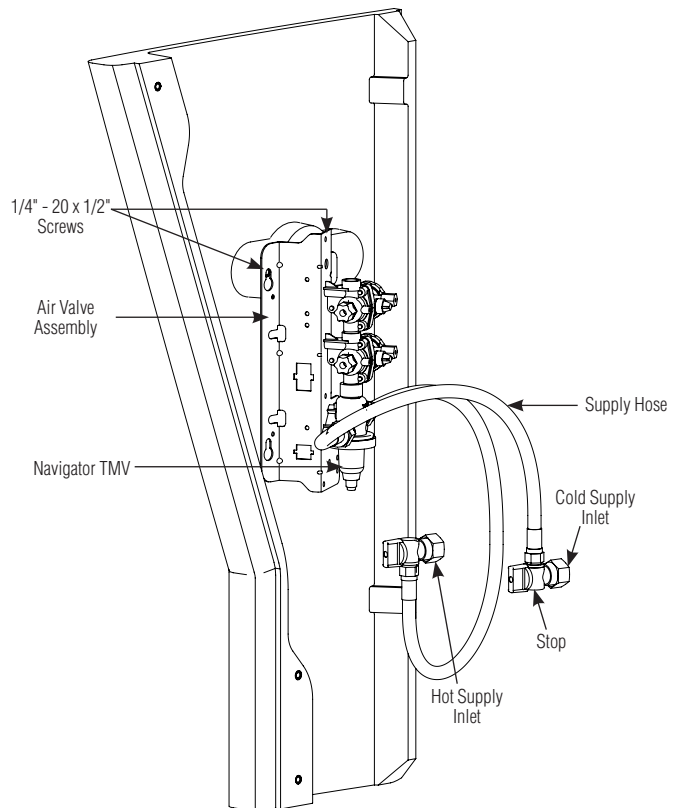

5 Assemble and Install Bowl



Do not leave the bowl on the pedestal unsupported, as it may fall and cause personal injury or damage to property.



Discard rubber gasket included with drain spud. It cannot be used in this application.



A Install two 3/8" wall anchors (supplied by installer) which will be used to mount the bowl to wall (see rough-ins on page 4).

B Carefully remove the sprayhead cover.

C Carefully lift the bowl onto the pedestal frame using appropriate lifting procedures. Ensure bowl remains 3-4" from the wall.

D Install the two wall anchor brackets to the back of the bowl using the 3/8"- 16 x 1-1/2" hex-head bolts, 13/32" I.D. plain washers, anchor plates, 3/8" I.D. lockwashers, and 3/8"- 16 hex nuts provided.

E Uncoil the push button and supply tubes from the rear of the backsplash.

F Slide the bowl back to the wall and secure the bowl's wall brackets to the wall anchors with two 3/8" bolts and washers (supplied by installer).

G Fasten the bowl to the upper bracket on the pedestal assembly with the two 1/4"- 20 x 1/2" round-head screws and 5/16" I.D. washers supplied.

H Install the drain spud in the bowl using plumber's putty.

I From beneath bowl, thread the spud washer and spud locknut onto the drain spud and tighten the locknut against the bowl.

J Install strainer in the bowl drain using the two #10-24 x 1/2" flat socket head screws supplied.

K Connect the drain trap (supplied by installer) to the drain spud and drain line.

Back View of Washfountain Bowl

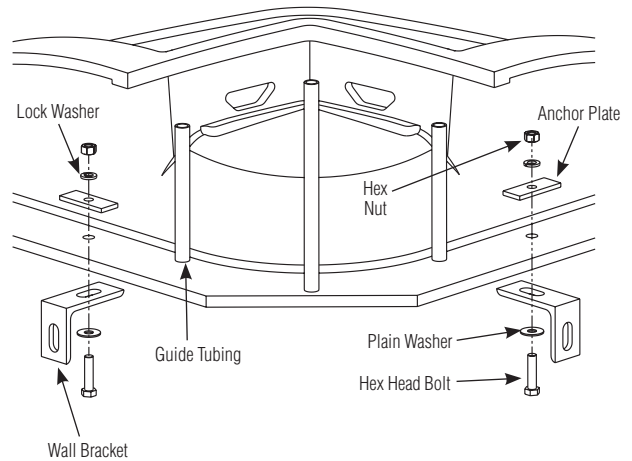

Drain Assembly

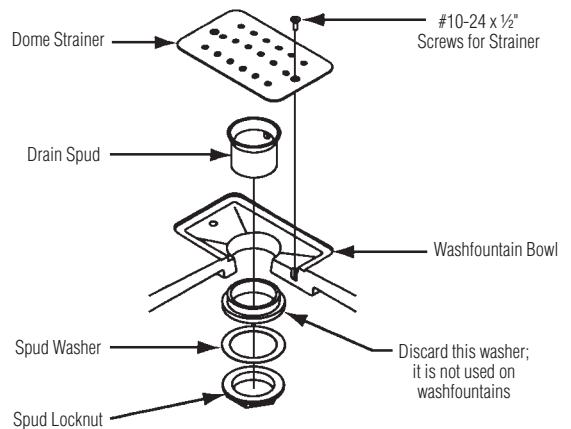

6 Connect Supply Line



Ensure that when you insert the tubes into the air valve assemblies that you keep the 1/8" and 1/4" tubes from each push button together. It does not matter which air valve you insert the sets of tubing in, as long as the 1/8" and 1/4" tubes from the same push button are inserted into the same air valve.

A Insert 1/4" tubing from the sprayhead aerators to the couplings on the air valves.

B Insert the 1/8" tubing from the push buttons to the connectors on the air valves.

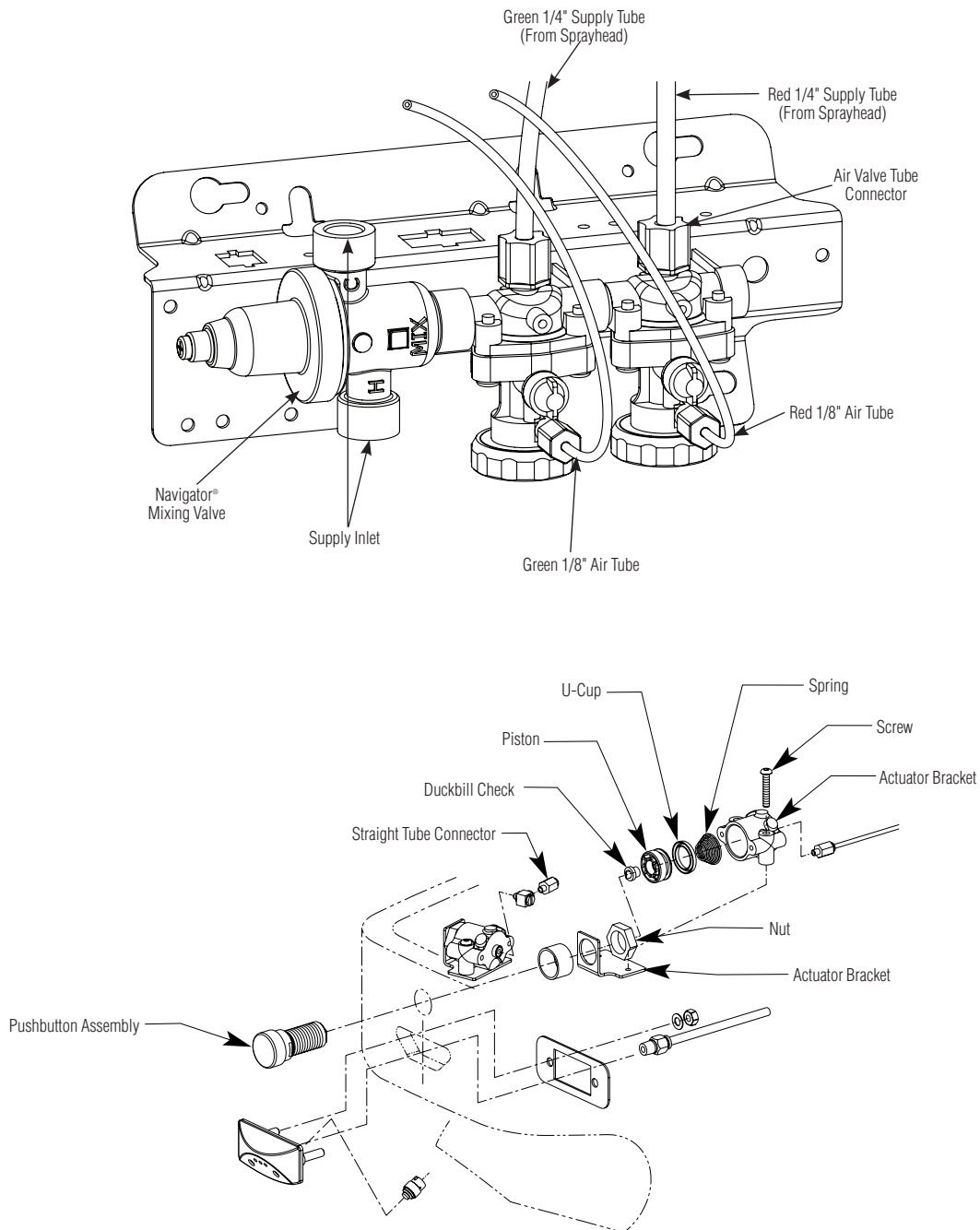

7 Check Operation

A Check to make sure both stops are fully open (see page 5).

B Turn on the main water supply to the Corner-Fount and check for leaks.

C Push operating push buttons until air is purged from lines.

D Loosen Cap Screw about 1/4" (4-6 turns) and lift up cover (do not remove).

E Using cover, turn cartridge gently until desired water temperature is reached. Do not turn past stops as this may damage unit. Push cover down and tighten screw.



This valve is NOT factory preset. Upon installation, the temperature of this valve must be checked and adjusted to ensure delivery of a safe water temperature. Water in excess of 110°F (43°C) may cause scalding.

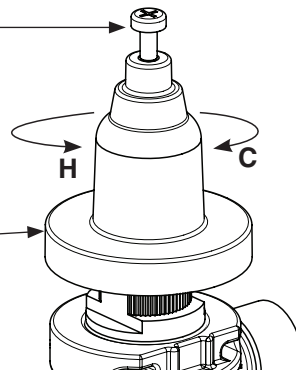

8 Install Top Cover and Front Panel

A Carefully place the top cover with threaded rods on top of washfountain sprayhead.

B Inside the pedestal assembly of the washfountain (use front access), slide the anchor plate onto the threaded rods and secure anchor plate against bowl using the wing nuts provided.

C To install front panel, slip slot in bottom of front pedestal panel over the lip on the lower bracket,

D Secure panel to upper bracket with attached screw.

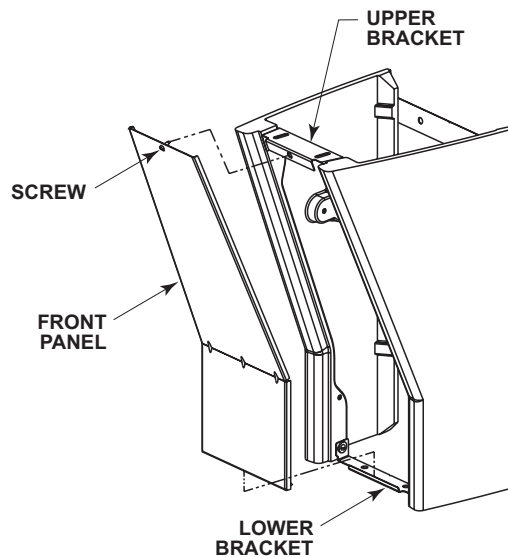
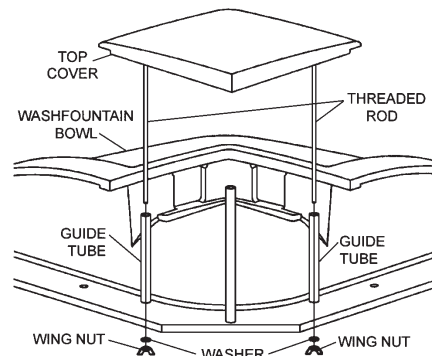

Cleaning and maintenance instructions for Terreon

Material Description: Terreon is an NAHB Certified densified solid surface material composed of polyester resin and is resistant to chemicals, stains, burns and impact. Surface damage can be easily repaired with everyday cleansers or fine grit abrasives.

Routine Cleaning: Clean daily or as often as conditions require using a standard commercial or household cleaner such as Formula 409® or Windex®.

Stubborn Stains: Remove tough stains with Ajax®, Comet®, or Soft-Scrub® and a green Scotch-Brite® pad or lightly sand in a circular motion with 240 grit wet/dry sandpaper. The finish can be renewed with a maroon Scotch-Brite pad.

Special Situations for Material

Scratches: Remove scratches with a green Scotch-Brite® pad. The finish can then be renewed with a maroon Scotch-Brite® pad.

Hard Water Deposits: Remove hard water deposits with a mild solution of vinegar and water. Always rinse the unit thoroughly after cleaning.

Restoring the surface: Use Hope's® Solid Surface cleaner and polish to refresh and protect the Terreon Solid Surface material. Bradley recommends additional care and maintenance for the darker colored Terreon. For complete instructions on this additional maintenance see Bradley document #1505.



Do not use strong acid or alkaline chemicals and cleansers to clean Terreon. If these chemicals come in contact with the Terreon surface, wipe them off immediately and rinse with soapy water.

Avoid contact with harsh chemicals such as paint remover, bleach, acetone, etc. Avoid contact with hot pans and objects.

Repair Kits: Terreon repair kits are available. Contact your Bradley representative or distributor for part numbers and pricing.



Repair kits are made to order and have a shelf life of 30 days.

Brand Names: Use of brand names is intended only to indicate a type of cleaner. This does not constitute an endorsement, nor does the omission of any brand name cleaner imply its inadequacy. Many products named are regional in distribution, and can be found in local supermarkets, department and hardware stores, or through your cleaning service. It is emphasized that all products should be used in strict accordance with package instructions.



When cleaning units equipped with infrared (electronic eye) activation, it is helpful to turn off the power to the unit or cover the windows to prevent accidental activation. After the window is covered, the water will run for approximately 30 seconds and then shut off.

Cleaning and maintenance instructions for stainless steel

Material Description: Stainless steel is extremely durable, and maintenance is simple and inexpensive. Proper care, particularly under corrosive conditions, is essential. Always start with the simplest solution and work your way toward the more complicated.

Routine cleaning: Daily or as often as needed use a solution of warm water and soap, detergent, or ammonia. Apply the cleaning solution per the manufacturer's instructions and always use a soft cloth or sponge to avoid damaging the finish.

Stubborn Stains: To remove stains from stainless steel use a stainless steel cleaner and polish such as Ball® stainless steel cleaner or a soft abrasive. Always follow the manufacturer's instructions and apply in the same direction as the polish lines.



Never use ordinary steel wool or steel brushes on stainless steel. Always use stainless steel wool or stainless steel brushes.

Special Situations for Material

Fingerprints and Smears: To remove fingerprints or smears use a high quality stainless steel cleaner and polish in accordance with the manufacturer's instructions. Many of these products leave a protective coating that helps prevent future smears and fingerprints.

Grease and Oil : To remove grease and oil use a quality commercial detergent or caustic cleaner. Apply in accordance to the manufacturer's instructions and in the direction of the polish lines.

Precautions: Avoid prolonged contact with chlorides (bleaches, salts), bromides (sanitizing agents), thiocyanates (pesticides, photography chemicals, and some foods), and iodides on stainless steel equipment, especially if acid conditions exist.



Do not permit salty solutions to evaporate and dry on stainless steel.

The appearance of rust streaks on stainless steel leads to the belief that the stainless steel is rusting. Look for the actual source of the rust in some iron or steel particles which may be touching, but not actually a part of the stainless steel structure.



Strongly acidic or caustic cleaners may attack the steel, causing a reddish film to appear. The use of these cleaners should be avoided.

Brand Names: Use of brand names is intended only to indicate a type of cleaner. This does not constitute an endorsement, nor does the omission of any brand name cleaner imply its inadequacy. Many products named are regional in distribution, and can be found in local supermarkets, department and hardware stores, or through your cleaning service. It is emphasized that all products should be used in strict accordance with package instructions.

Metering Air Valve Maintenance

 The air valve timer is located next to the tube connector on the air valve body. The timer is capped with a filter to prevent dirt build-up on the timer. The air valve timing can be adjusted from 5–60 seconds.

Adjust Air Valve Meter Time

A Remove filter cap and use a screwdriver to tighten or loosen the timer (see illustration at right). Turning the timer clockwise increases the time; turning the timer counterclockwise decreases the time.

B Continue to adjust until the timer is set at desired length.

C Replace filter cap over the timer.

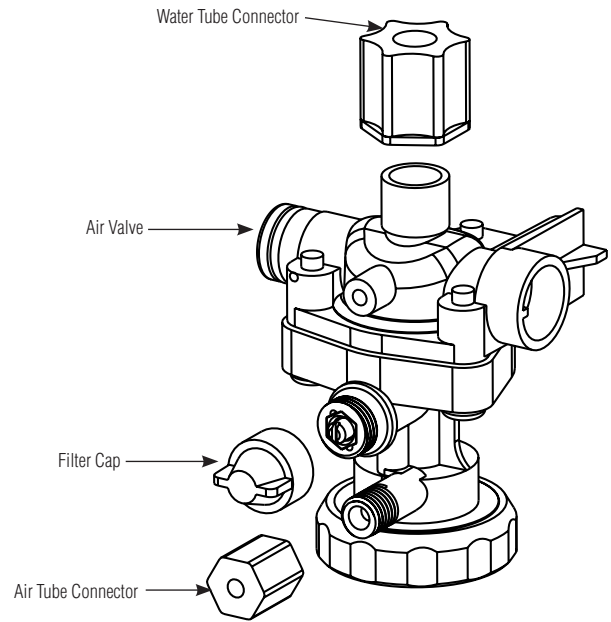

Tube Connection Leaks

A Push in the orange manual release button while pulling the tube out (see illustration at right) to disconnect the tube at the connector. No tools are needed.

B To correct a leak, press tubing firmly into the connector and make sure it is seated.

C If leak persists, remove tubing from the fitting, and trim the tubing end square with a razor-sharp knife. If leak continues, replace the fitting or contact your Bradley representative for assistance.

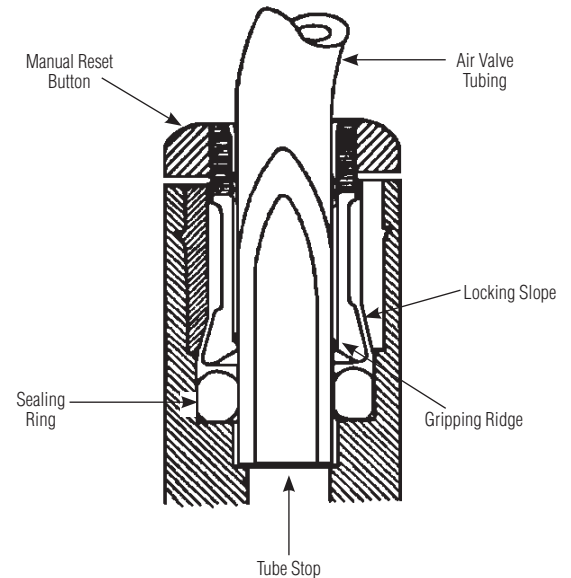

AST4 Valve Repair Kits

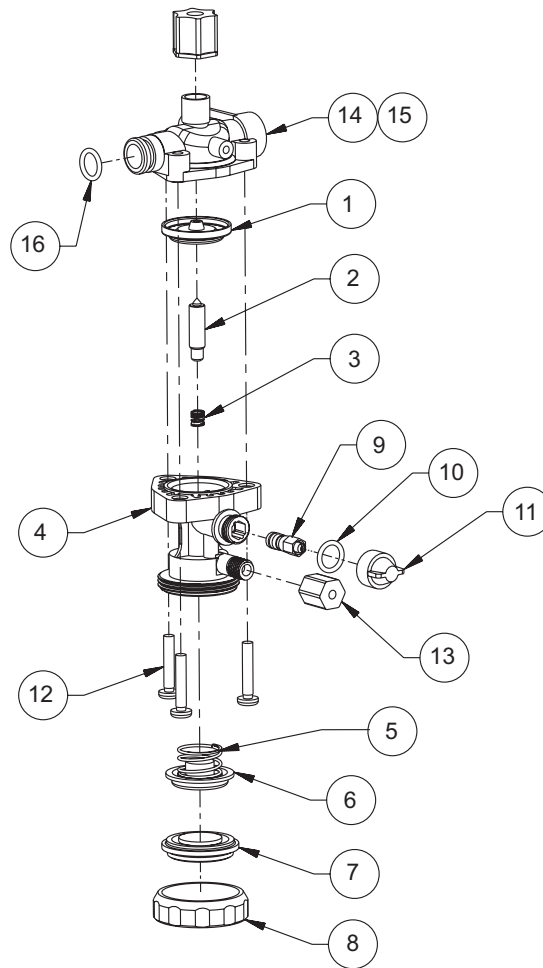

AST4 Valve Repair Kits

Item	Description	AST 4 Valve Kit S65-260	Repair Kit (Upper) S65-261	Repair Kit (Lower) S65-262	AST4 1/4" Tube Valve S07-078S	AST4 1/4" Tube Valve S07-078AS
		Qty				
1	Diaphragm	1	—	1	1	1
2	Armature	1	—	1	1	1
3	Spring	1	—	1	1	1
4	AST 4 Valve Upper Body	1	—	—	1	1
5	Spring	1	1	—	1	1
6	Magnet / Diaphragm Assembly	1	1	—	1	1
7	AST 4 Valve Cover	1	1	—	1	1
8	AST 4 Valve Clamp Nut	1	1	—	1	1
9	AST 4 Valve Timer Assembly	1	—	—	1	1
10	O-Ring, #2-012	1	—	—	1	1
11	AST 4 Valve Timer Cover	1	—	—	1	1
12	Screw, #8 x 7/8"	3	—	—	1	1
13	Compression Nut, 1/8" Tube	1	1	—	1	1
14	Valve Body 1/4 Tube, Closed	—	—	—	1	—
15	Valve Body 1/4 Tube, Thru	—	—	—	—	1
16	O - Ring	—	—	—	1	1

Metering Air Valve Troubleshooting

Problem: Valve will not shut off.

Cause: Timing mechanism is clogged.

Solution: Clean and inspect timing mechanism:

1. If compressed air is available, blow water and debris from timer cover of timing mechanism.
2. Turn adjusting screw out all the way. Clean and inspect screw and valve body.
3. Turn adjusting screw in to desired cycle time.

Problem: Valve will not turn on.

Cause: Water is not being supplied to unit.

Solution: Open all stops on mixing valve.

Cause: Water pressure is over 80 PSI.

Solution: Install a pressure reducing valve.

Cause: Failed diaphragm/magnet assembly.

Solution: Unscrew the valve clamp nut on valve. Remove valve cover. Gently press the diaphragm. The valve should activate. If not, replace the diaphragm/magnet assembly.

Problem: Timing can not be adjusted for more than 5 seconds.

Cause: There is an air leak.

Solution: Check the valve assembly:

1. Check all tubing and fittings for proper assembly.
2. Tighten cap and nut on 1/8" tubing.

Problem: Push button does not work properly.

Cause: Air volume may not be sufficient to operate valve.

Solution: Check for leaks and lubricate U-cup:

1. Check all fittings for air leaks.
2. Disassembly push button and lubricate U-cup seal.

Problem: Water is dripping from the streamformers.

Cause: Debris has accumulated on valve seat or orifices.

Solution: Clean and inspect valve seat.

1. Remove screws and disassemble metering valve.
2. Clean valve seat and inspect for deep gouges or scratches. Replace valve body if necessary.
3. Remove any debris clogging off-center hole in rubber diaphragm.

Thermostatic Mixing Valve Troubleshooting



Before attempting to troubleshoot the valve or disassemble the components, check for the following conditions:

- If stop valves are used, make sure that they are fully open.
- Make sure that the hot and cold inlet pipes are connected properly, and that there are no cross-connections or leaking stop valves.
- Check the hot water heater output to make sure that it is at least 10° F above the set temperature.



Be sure to close the appropriate shut-off valves prior to disassembly of the valve and reopen the valves after inspection and repair is complete.

Problem	Cause	Solution
External leaks.	Damaged cartridge or O-rings.	Replace cartridge with part number 269-1927
Improper water temperature or temperature fluctuation.	Hot water supply is not 10° above desired set point.	Increase hot water supply temperature
	Valve temperature is not properly set.	Adjust the temperature as shown on page 8 step 7.
Limited water flow.	Dirt and debris have built up in the valve or strainer.	1. Check to make sure both hot and cold supplies are connected to the Navigator mixing valve and that they have water flow. 2. Remove cover and U-clip. Remove the cartridge and clean the strainer. It is not required to grease cartridge, however if desired, use silicone grease only. Do not use grease on check valves.

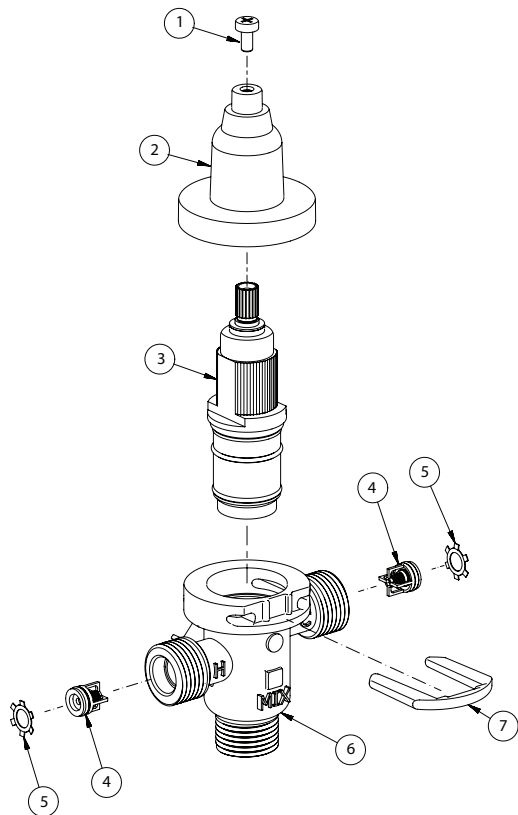

Parts List

Item	Part No.	Description	Quantity
			S59-4000
1	160-463	Cap Screw	1
2	107-582	Cover	1
3	269-1927	Thermostatic Cartridge	1
4	198-014	Check Valve*	2
5	132-051	Retaining Ring*	2
6	118-319	Valve Body	1
7	146-079	U-Clip	1

* Included with Prepack S65-326

Tempered Line Adapter Option Part no. S39-804

(replaces S59-4000 if tempered line is used)

