

Installation

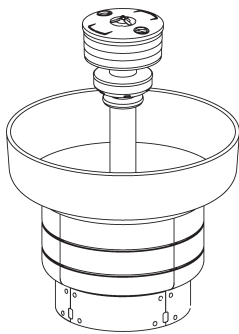

WF2505 with
Infrared Control

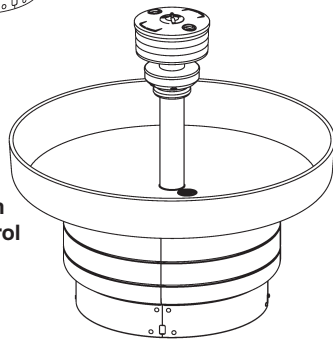

WF2508 with
Infrared Control

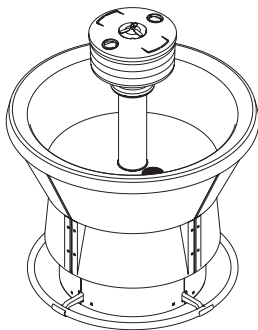

WF2805 with
Infrared Control

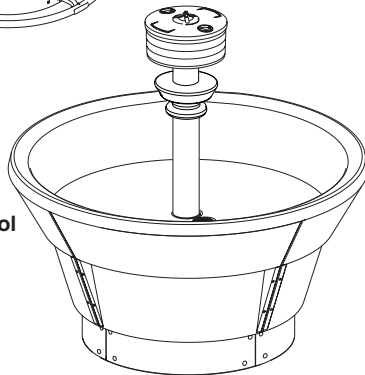

WF2808 with
Infrared Control

WF2505

Terreon® 36" Pre-Assembled Circular
Classic Washfountain with Infrared Control

WF2508

Terreon® 54" Pre-Assembled Circular
Classic Washfountain with Infrared Control

WF2805

Bradstone® 36" Pre-Assembled Circular
Classic Washfountain with Infrared Control

WF2808

Bradstone® 54" Pre-Assembled Circular
Classic Washfountain with Infrared Control

Table of Contents

Pre-Installation Information	2
Circular Washfountain Dimensions	3
Rough-In Specifications	4-5
Installing the Drain	6
Bowl/Pedestal Mounting and Assembly	7
Installing Drain Spud in Bowl	8
Installing Supplies w/ Optional Soap Dispenser	9-10
Valve Connections for Infrared	11
Electrical Connections for Infrared	12
Adjust the Temperature	13
Cleaning and Maintenance	14-15
Soap Valve Parts List and Maintenance	16-17
Sprayhead Parts List and Troubleshooting	18
Infrared Troubleshooting	19
Solenoid Valve Troubleshooting	20
Stop, Strainer and Check Valve Parts List	21
Check Valve Troubleshooting	21
Valve Assembly Parts	22-24
Thermostatic Mixing Valve Troubleshooting	25

IMPORTANT!

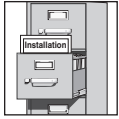

Read this entire installation manual to ensure proper installation. When finished with the installation, file this manual with the owner or maintenance department.



Separate parts from packaging and make sure all parts are accounted for before discarding any packaging material. If any parts are missing, do not begin installation until you obtain the missing parts.

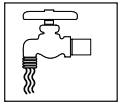

Make sure that all water supply lines have been flushed and then completely turned off before beginning installation. Debris in supply lines can cause valves to malfunction.



Product warranties may be found under "Product" on our web site at www.bradleycorp.com.

Supplies Required by Installer

- (8) 1/2" lag bolts, screws or other fasteners to anchor washfountain pedestal
- 1" hot and cold water supply lines and fittings
- Reducing fittings and 1/2" nom. copper tubing supply lines for types with supplies from above
- 2" drain lines and fittings
- Standard P-trap (special vented trap supplied for B and H type)
- Pipe sealant and plumber's putty
- 1-1/2" vent pipe on types vented through washfountain column
- 110 VAC GFI power source for 110/24 VAC UL Class II transformer supplied
- OPTIONAL: Bradley recommends installing an electrical cut-off switch to the unit. This feature prevents accidental water delivery during regular maintenance and service



Supply lines for one or two washfountains should be 1"; for three washfountains 1-1/4"; for more than three washfountains pipe size should increase proportionally. Vent pipe to be 1-1/2" on models vented through washfountain.

Pre-Installation Information

Terreon Material

Adensified solid surface material composed of polyester resin. Terreon is resistant to chemicals, stains, burns and impact. Surface damage can be easily repaired with everyday cleaners or fine-grit abrasives. Terreon is NAHB certified to meet ANSI Z124.3, Z124.6 and ANSI/ICPA SS-1-2001.

Bradstone Material

An extremely durable plastic material made of reinforced thermosetting polyester resins, finely ground inorganic fillers and fade resistant pigments.

Adaptive Infrared

The sprayhead is controlled by a solenoid valve, allowing the user to activate a flow of water. The Infrared sensor will take a few minutes to adapt to its environment when the unit is powered up.

Circular Washfountain Dimensions

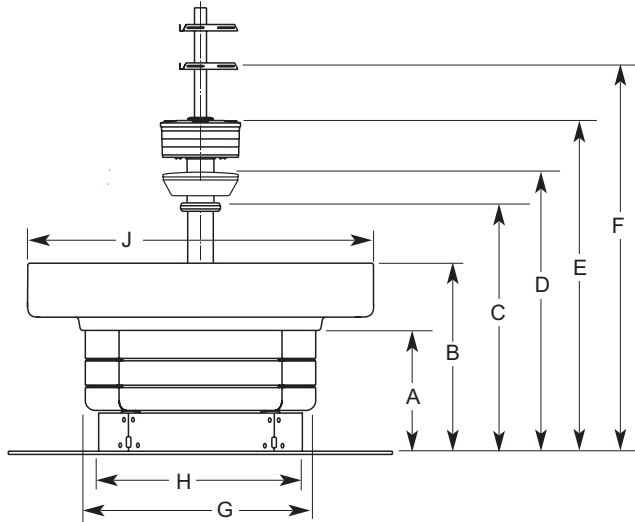

Approximate Dimensions in Inches

Material	Size	A	B	C	D	E	F	G	H	J
Terreon	54	19*	29-1/2*	38-3/4*	42-1/4*	50-3/4*	59-1/4	36	32	54
Terreon	36	19*	29-1/2*	35-1/4*	38-3/4*	46-3/4*	55-3/4	25	21	36
Bradstone	54	19-3/4	29-1/4	37-1/2	41	49-1/2	57-7/8	36	32	54
Bradstone	36	19-3/4	29-1/4	34	37-1/2	46	54-3/8	25	21	36

* Subtract 4" from dimensions for juvenile height. (Bradstone not available in juvenile height)

Approximate Dimensions in Millimeters

Material	Size	A	B	C	D	E	F	G	H	J
Terreon	1372	483*	749*	984*	1073*	1289*	1505	914	813	1372
Terreon	914	483*	749*	895*	984*	1188*	1416	635	533	914
Bradstone	1372	502	743	953	1041	1257	1470	914	813	1372
Bradstone	914	502	743	864	953	1169	1381	635	533	914

* Subtract 102mm from dimensions for juvenile height. (Bradstone not available in juvenile height)

Length of Tie Pipe Required for Vent Through Washfountain Column

Type	Pipe Length
54" Less Soap Dispenser	21-1/2" (546mm)
36" Less Soap Dispenser	18" (457mm)
54" With Soap Dispenser	30" (762mm)
36" With Soap Dispenser	26-1/2" (673mm)
54" Less Soap Dispenser With Towel Dispenser	55-1/2" (1410mm)
36" Less Soap Dispenser With Towel Dispenser	52" (1321mm)
54" With Soap Dispenser With Towel Dispenser	48" (1219mm)
36" With Soap Dispenser With Towel Dispenser	44-1/2" (1130mm)
54" With Cube Adapter	32" (813mm)
36" With Cube Adapter	28-1/2" (724mm)
54" With Cube Adapter With Towel Dispenser	50" (1270mm)
36" With Cube Adapter With Towel Dispenser	46-1/2" (1181mm)
54" With Cube Adapter And Soap Dispenser	40" (1016mm)
36" With Cube Adapter And Soap Dispenser	36-1/2" (927mm)



Drain must be connected with 2" schedule 40 welded wrought iron pipe, minimum, to provide lower support for this installation. Vent or support pipe must be of the same material in 1-1/2".

Rough-In Specifications

Notes For All Models:

- All pipes and fittings not furnished by Bradley are shown in broken lines.
- Supply lines for one to two washfountains should be 1"; for three washfountains 1-1/4"; for more than three washfountains, pipe sizes should be increased proportionately.
- Overhead supplies must be reduced to 1/2" copper tube to pass through support tube.
- Check valve inlets are 1/2" NPT.
- Dimensions shown in parentheses are millimeters.

* Remote mounting of transformer with 24 VAC electrical supply to washfountain is recommended (this conduit location is only a recommendation). See local electrical codes before roughing in.

Type A

Off-line vent with supplies from below

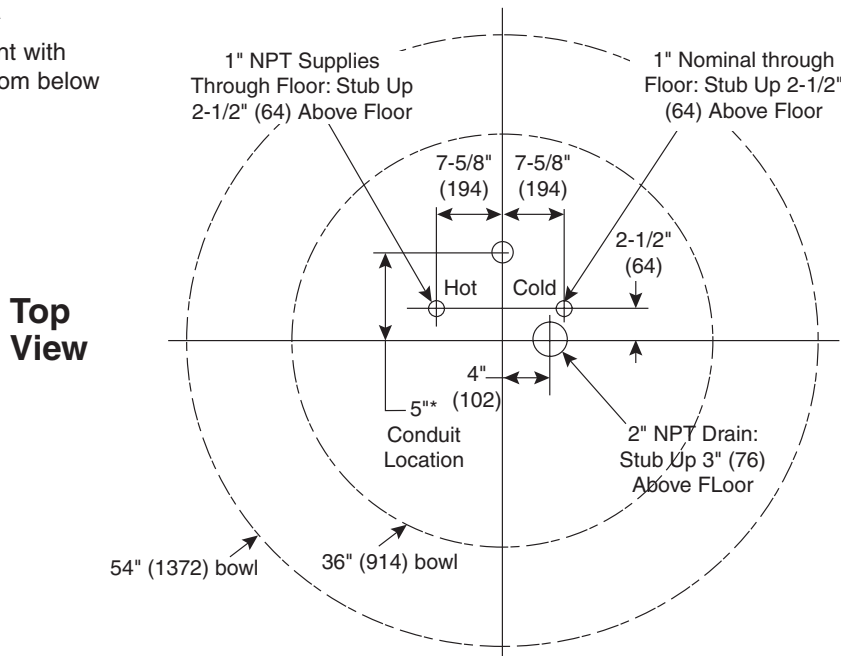

 *UPC and IPC restrict the vertical distance from the fixture outlet to the trap weir to not more than 24". Check state and local codes for variances.*

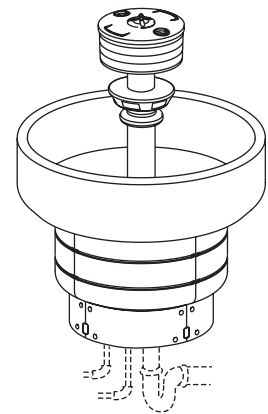

Type B

Centrally rising vent with supplies from above

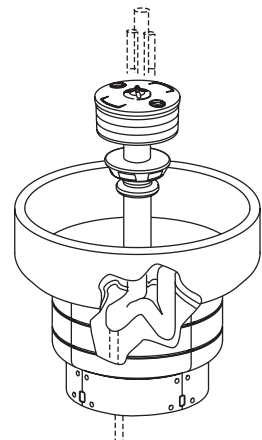
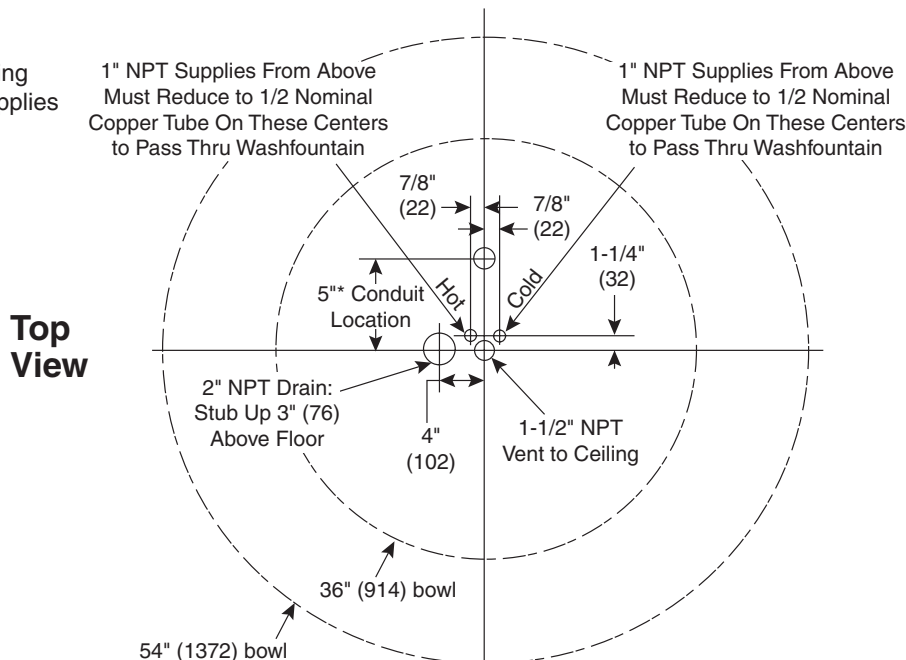

Rough-In Specifications

Notes For All Models:

- All pipes and fittings not furnished by Bradley are shown in broken lines.
- Supply lines for one to two washfountains should be 1"; for three washfountains 1-1/4"; for more than three washfountains, pipe sizes should be increased proportionately.
- Overhead supplies must be reduced to 1/2" copper tube to pass through support tube.
- Check valve inlets are 1/2" NPT.
- Dimensions shown in parentheses are millimeters.

*** Remote mounting of transformer with 24 VAC electrical supply to washfountain is recommended (this conduit location is only a recommendation). See local electrical codes before roughing in.**

Type O

Off-line vent with supplies from below

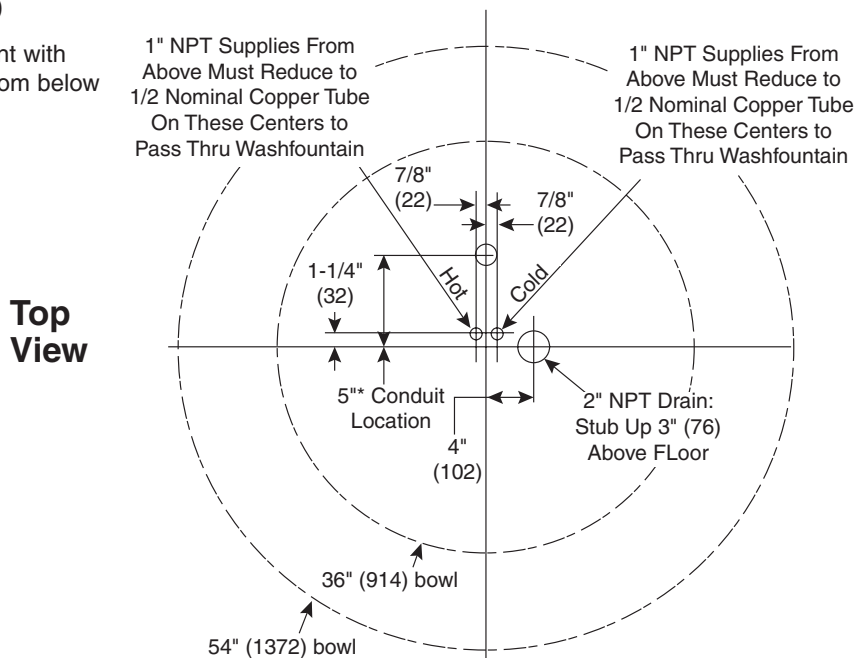

UPC and IPC restrict the vertical distance from the fixture outlet to the trap weir to not more than 24". Check state and local codes for variances.

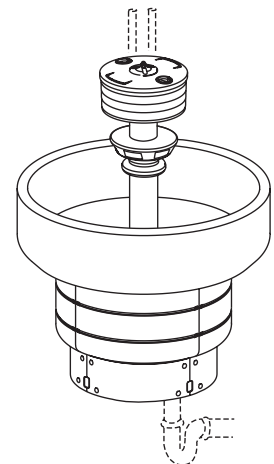

Type H

Centrally rising vent with supplies from above

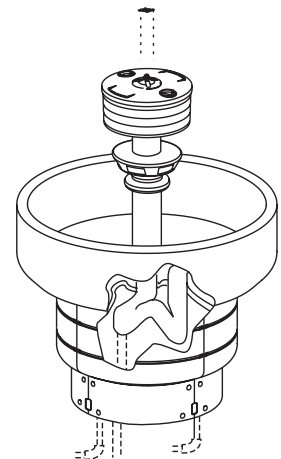
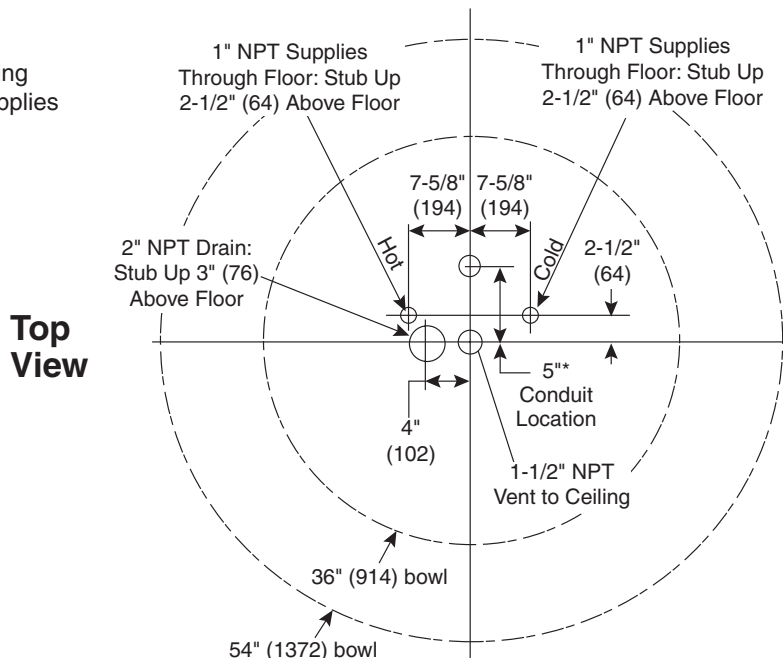

1 Installing the Drain

A Rough in supply and drain piping as required for your installation.

B Assemble the drain to the dimension shown below for the bowl size you are installing.



All piping shown in dotted lines to be supplied by installer.



When an Infrared control is ordered, a plug-in location for the 24 VAC transformer is required. Compliance/conformity to local codes and ordinances is the responsibility of the installer.

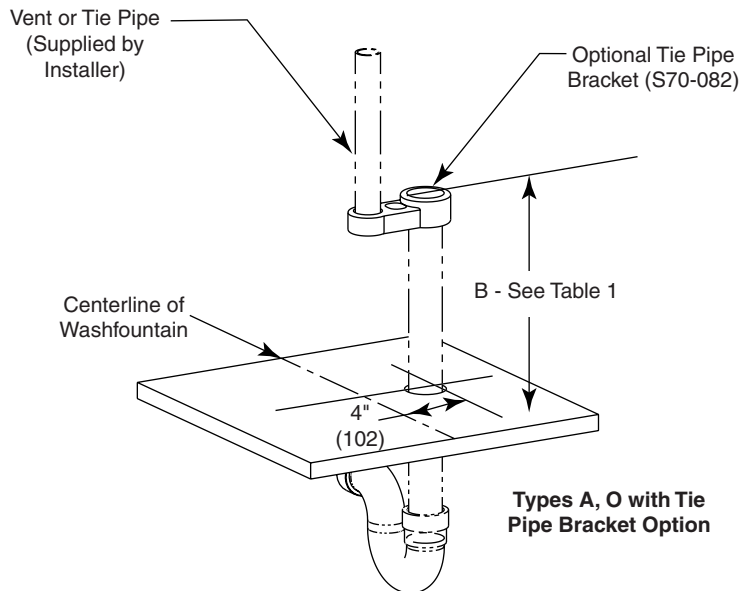
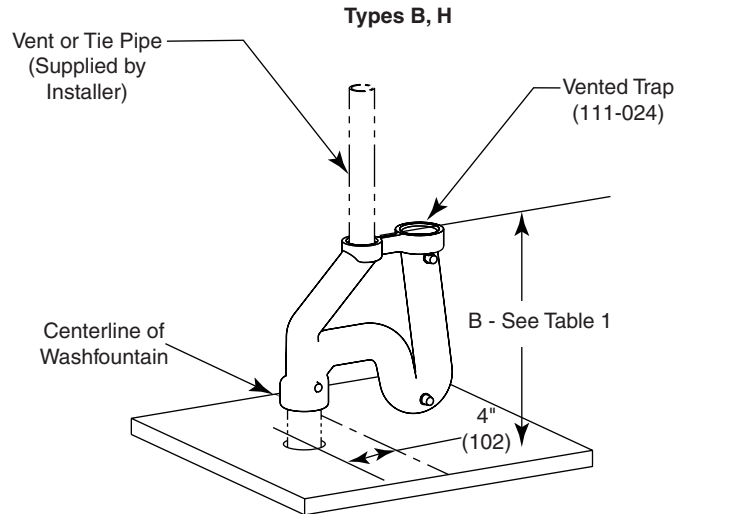
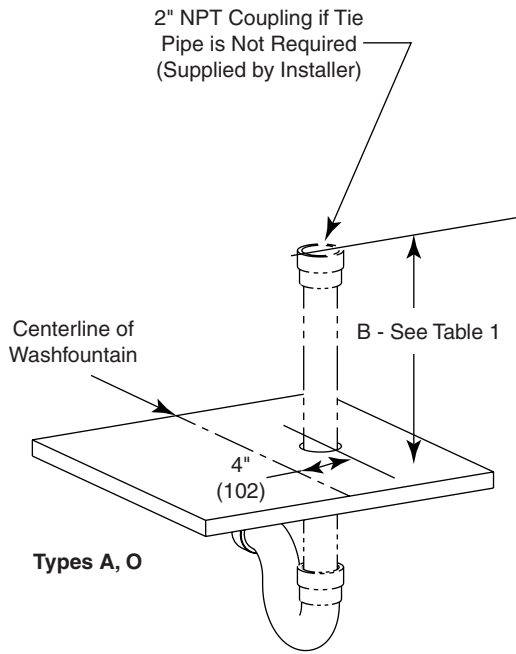

See Rough-In information for dimensions not shown.

"B" Trap Dimensions

Material	Size	Dimension	Standard Height	Juvenile Height
Terreon	36"	B	18-5/8" (473mm)	14-5/8" (371mm)
Terreon	54"	B	18-5/8" (473mm)	14-5/8" (371mm)
Bradstone	36"	B	17-3/8" (441mm)	N/A
Bradstone	54"	B	17" (432mm)	N/A

2 Bowl/Pedestal Mounting and Assembly

CAUTION! Bowl surface is very smooth. Approximate weight of bowl is 73 pounds. Handle with Care!

 (Terreon only) It will require more than one person to turn the bowl/pedestal assembly upright. (It is shipped with the bowl on the bottom).

A Position the bowl and pedestal assembly so that the bowl drain is in line with trap or drain line.

B Drop the spud into the drain to insure correct alignment

C Level bowl, if required, by placing washers under legs.

D Anchor the pedestal to the floor with suitable fasteners (supplied by installer)

 The pedestal must be level when secured to floor for proper drainage.

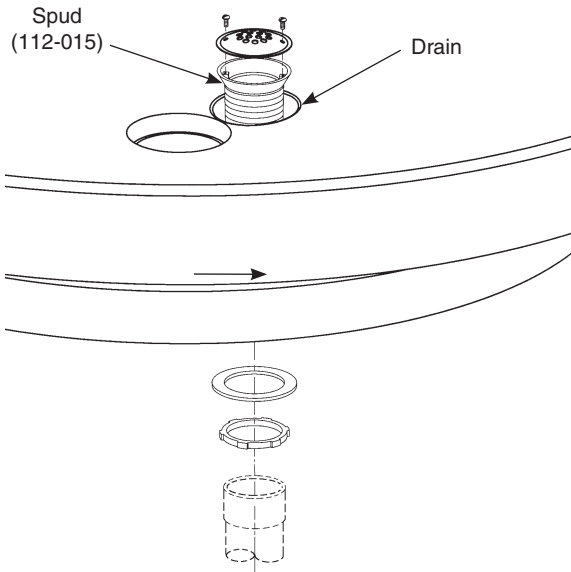

TOP VIEW OF PEDESTAL ASSEMBLY

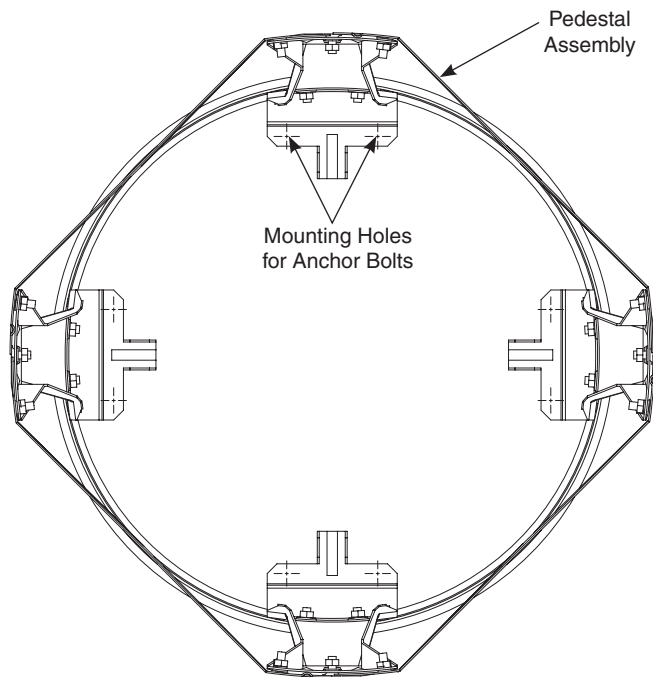

3 Installing Drain Spud in Bowl

A Loosely attach the drain spud to the bowl with the locknut and washer.

B Trap Option: Attach B trap to drain spud.
Tie Pipe Option: Attach tie pipe bracket to drain spud.

B Tighten the spud and lock nut against bowl.

C Secure the strainer to drain spud with screws provided.

D Connect spud (or B Trap or Tie Pipe Bracket) to drain.



Seal between drain spud and drain hole with plumber's putty (supplied by installer).

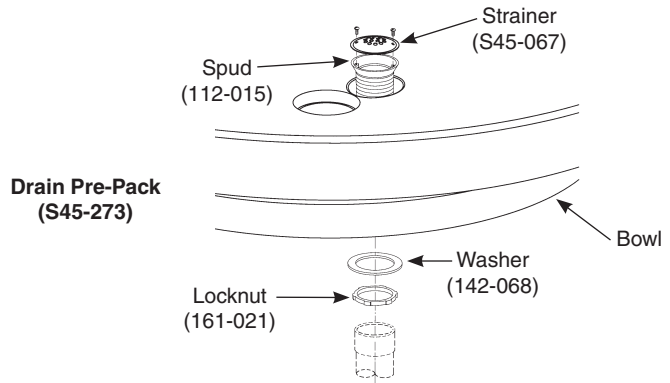

4a Installing Supplies with Optional Soap Dispenser for A/O drain units



For models with optional paper towel dispensers, tie pipe assembly, or shroud, see separate instruction sheets

A Install hemmed end (not sharp end) of support tube with gasket onto bowl.

Connect 1/2" supply tubing to sprayhead.

- Using a sharp knife, cut tubing squarely and remove any burrs. DO NOT pinch or crush end of tubing.
- Loosen nut on fitting. Moisten end of tube and push into fitting until it is firmly seated. Tighten nut to secure tube to fitting (make sure nut is securely tightened).
- If connector leaks, reseal tubing according to above procedure. If leaking persists, replace male connector, or call your Bradley representative for assistance.

C Place sprayhead with 1/2" tubing onto support tube. Run tubing down through support tube.

D Assemble the lower tie rod (the longer threaded rod), upper tie bar (notched at corners), lower tie bar, tie rod nut, and coupling nut, then attach the 4-1/4" tie rod to coupling nut.

E Place infrared module assembly on top of sprayhead. Rotate until infrared module locks in with tie bar. Drop the infrared module wires down into the pedestal.

F **FOR UNITS WITH SOAP OPTION:** Install the spacer, soap dispenser and cover using the coupling nut, third tie rod (8-5/8" long) and second coupling nut. Secure with acorn nut and socket head set screw.

FOR UNITS WITHOUT SOAP OPTION: Secure infrared module cover and dispenser cover with acorn nut and socket head set screw.

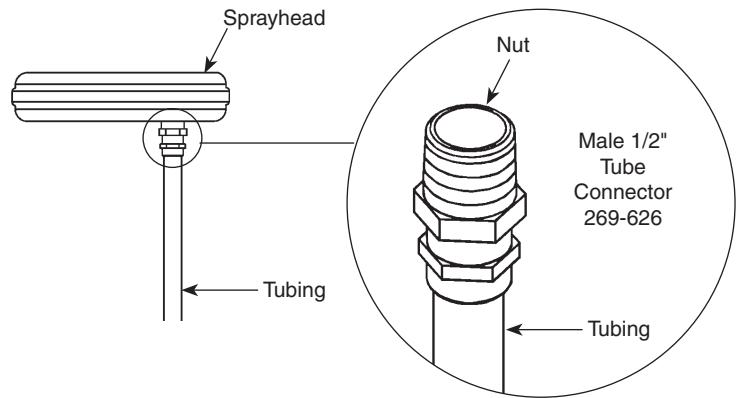

Type "O" Drain
(Supplies from Above)

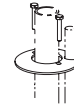

Acorn Nut (110-052A) and Set Screw (160-093)

Type "A" Drain

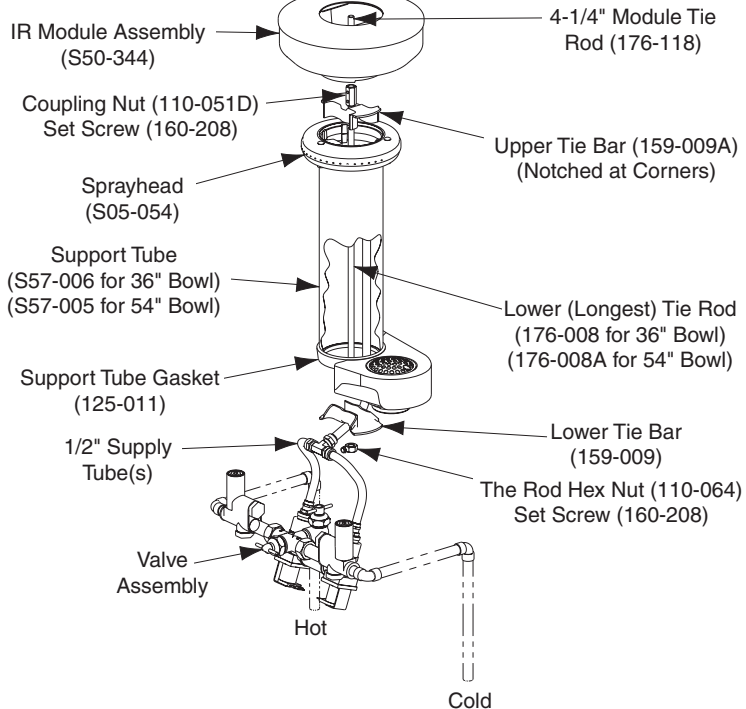
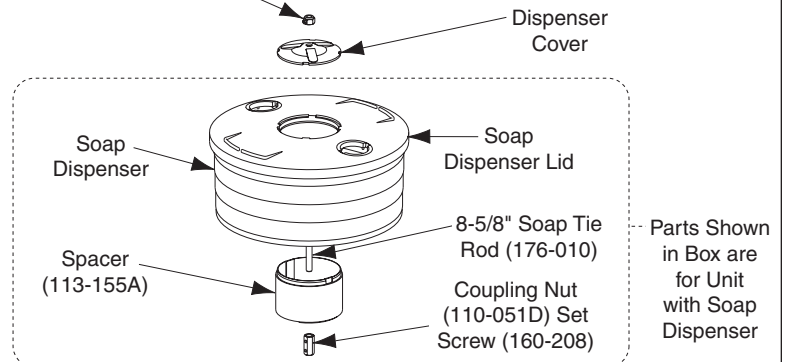

4b Installing Supplies with Optional Soap Dispenser for B/H drain units



For models with optional paper towel dispensers, tie pipe assembly, or shroud, see separate instruction sheets

A Install hemmed end (not sharp end) of support tube with gasket onto bowl

Connect 1/2" supply tubing to sprayhead.

- Using a sharp knife, cut tubing squarely and remove any burrs. DO NOT pinch or crush end of tubing.
- Loosen nut on fitting. Moisten end of tube and push into fitting until it is firmly seated. Tighten nut to secure tube to fitting (make sure nut is securely tightened).
- If connector leaks, reseal tubing according to above procedure. If leaking persists, replace male connector, or call your Bradley representative for assistance.

C Place sprayhead with 1/2" tubing onto support tube. Run tubing down through support tube.

D Place infrared module assembly on top of sprayhead. Drop two infrared module wires down into the pedestal.

E Insert the 1-1/2" vent pipe through the infrared module, sprayhead, and support tube.

FOR UNITS WITH SOAP OPTION: Place the spacer, soap dispenser and cover in position on top of IR module. Slide tie bar over 1-1/2" vent pipe 1/2" below top of soap dispenser lid and secure with the two cap screws included with the tie bar. Slide the dispenser cover over 1-1/2" vent pipe and secure with the two cap screws included with the tie bar.

FOR UNITS WITHOUT SOAP OPTION: Slide tie bar over 1-1/2" vent pipe, 1/2" below top of infrared module and secure with set screws. Slide the dispenser cover over 1-1/2" vent pipe and secure with the two cap screws included with the tie bar.

G Connect vent pipe to vent through ceiling with pipe union.

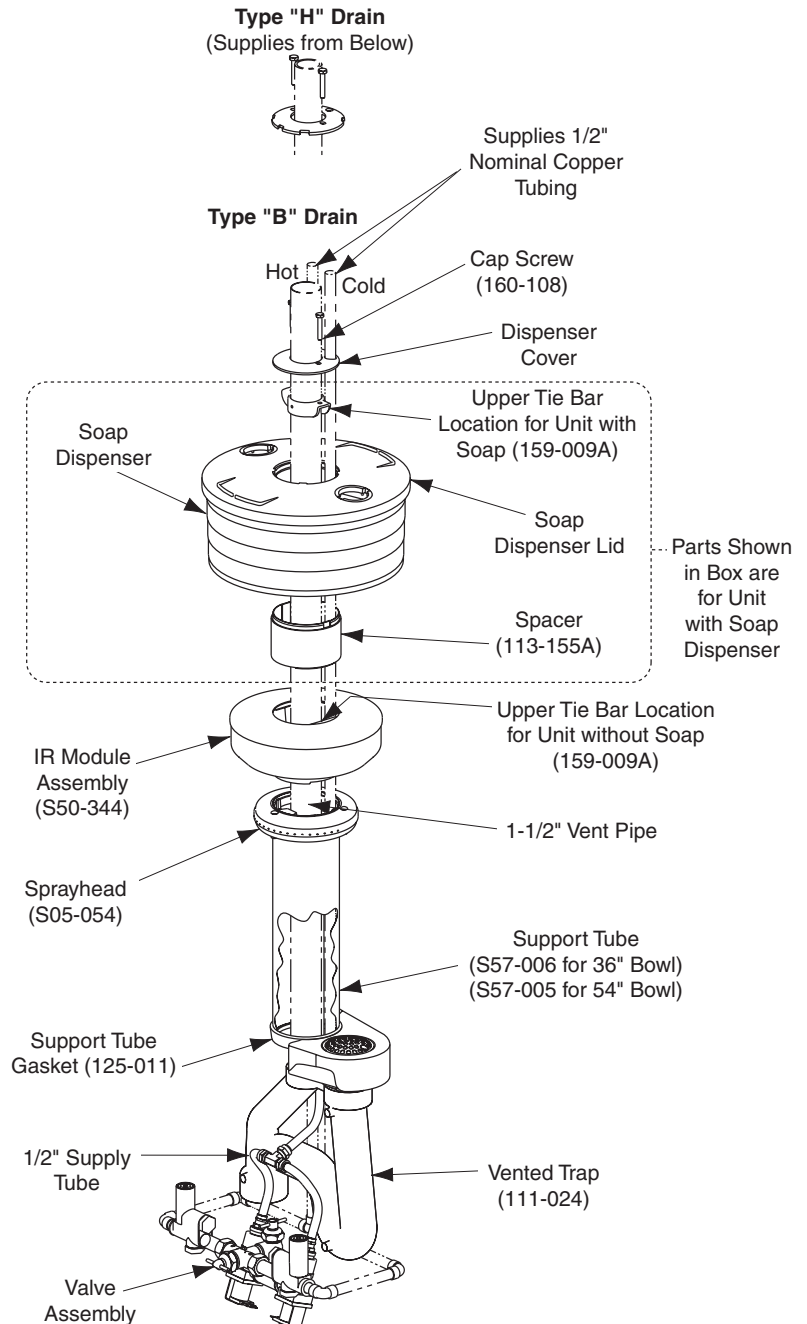

5 Valve Connections for Infrared

 Flush supply lines before making connections.

A Connect the solenoid valve assembly to the mixing valve assembly. Use pipe sealant to seal threads.

B For overhead supply lines, install 1/2" nominal copper supply tubing by passing the lines through the holes in the dispenser cover and down through the support tube.

C Using suitable fittings, install the complete valve assembly to the supplies at the approximate height indicated in table to the right.

D Attach 1/2" tubing and tee to the solenoid valve assembly.

E Connect the 1/2" supply tubing from the sprayhead to the tee.

Distance from 1/2" Supply to Finished Floor		
Model Number	Type A or O	Type B or H
Standard Height	9" (229mm)	6-3/16" (157mm)
Juvenile Height	5-1/4" (133mm)	3-7/16" (87mm)

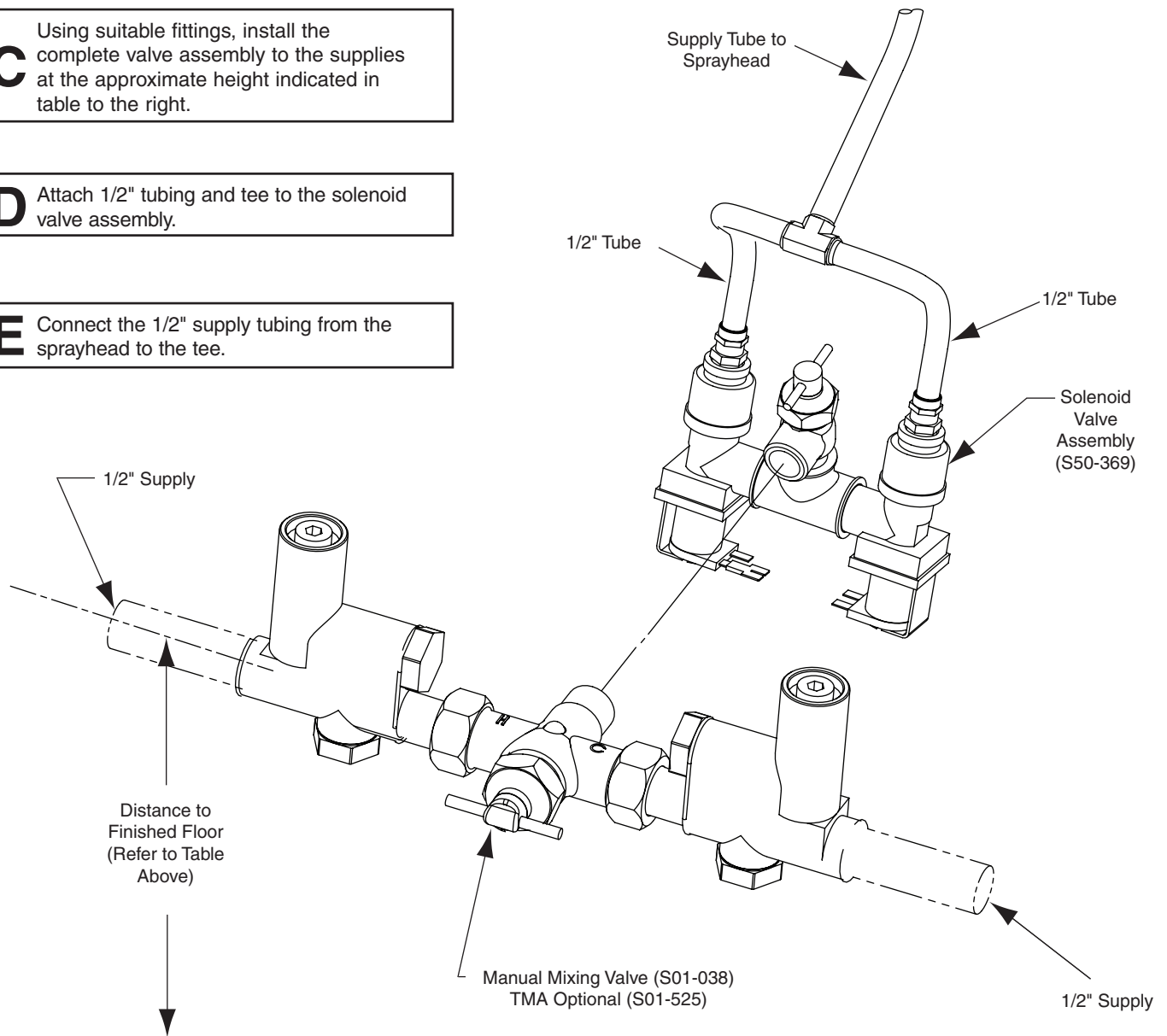

6 Electrical Connections for Infrared

A Attach the wire leads with female connectors (red wire) from the infrared module to the solenoids.



Do not use for two minutes after making power connection. The sensors will take up to eight minutes (without being used) to adapt to the bowl if another object is detected during the two-minute start-up period.

B Attach the wire with the male connector (black wire) from the infrared module to the transformer lead wire.



Clean sprayhead if necessary. Adjust volume control valve, if necessary, to control the flow of water.

C Attach the remaining transformer lead wire to the solenoid.

D Plug the 24 VAC Class II transformer into a 110 VAC GFI outlet.

E Turn supplies on and check piping installation for leaks.

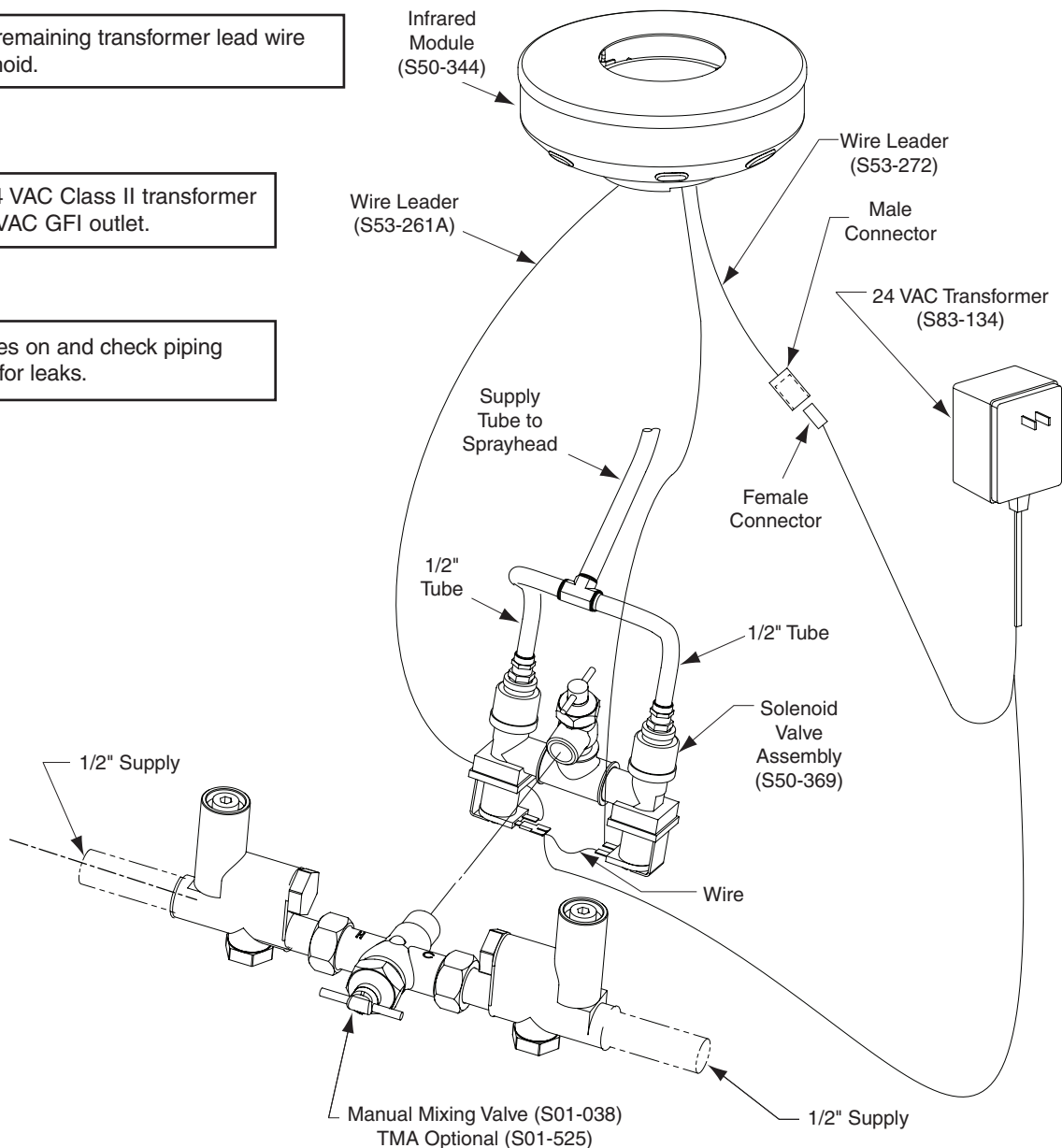

7 Adjusting the Temperature

CAUTION: This valve is NOT factory preset. Upon installation, the temperature of this valve must be checked and adjusted to ensure delivery of a safe water temperature. Water in excess of 110°F (43°C) may cause scalding.

Check the temperature when approximately 1.0 GPM water flow is reached and adjust if necessary (the range of the valve is 95°F–115°F (35°C–43°C). To adjust the temperature:

- A**
- Loosen temperature locking nut with wrench.
 - Using a blade screwdriver, turn the adjustment stem counterclockwise to increase the temperature or clockwise to decrease the temperature
 - Once desired temperature has been reached, tighten lock nut to prevent change in temperature.

B Shut the hot water inlet off by closing the hot water stop-strainer-check valve. While the hot water supply is turned off, check to make sure the cold water flow is reduced. If the cold water is reduced properly, reopen the hot water supply.

C Shut the cold water inlet off by closing the cold water stop-strainer-check valve. While the cold water supply is off, check to make sure that the hot water flow has shut down.

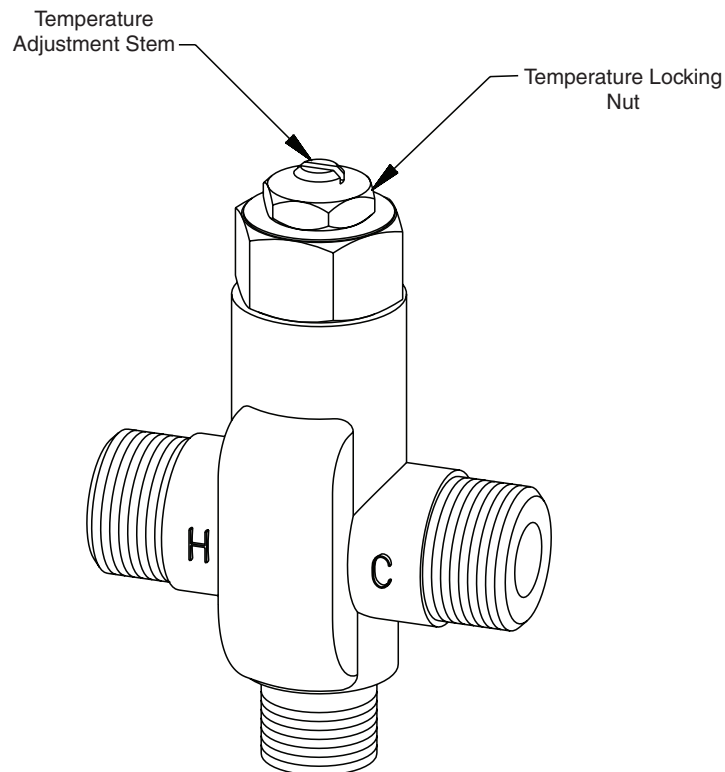

Cleaning and maintenance instructions for Terreon

Material Description: Terreon is an NAHB Certified densified solid surface material composed of polyester resin and is resistant to chemicals, stains, burns and impact. Surface damage can be easily repaired with everyday cleansers or fine grit abrasives.

Routine Cleaning: Clean daily or as often as conditions require using a standard commercial or household cleaner such as Formula 409® or Windex®.

Stubborn Stains: Remove tough stains with Ajax®, Comet®, or Soft-Scrub® and a green Scotch-Brite® pad or lightly sand in a circular motion with 240 grit wet/dry sandpaper. The finish can be renewed with a maroon Scotch-Brite pad.

Special Situations for Material

Scratches: Remove scratches with a green Scotch-Brite® pad. The finish can then be renewed with a maroon Scotch-Brite® pad.

Hard Water Deposits: Remove hard water deposits with a mild solution of vinegar and water. Always rinse the unit thoroughly after cleaning.

Restoring the surface: Use Hope's® Solid Surface cleaner and polish to refresh and protect the Terreon Solid Surface material. Bradley recommends additional care and maintenance for the darker colored Terreon. For complete instructions on this additional maintenance see Bradley document #1505.

NOTICE! Do not use strong acid or alkaline chemicals and cleansers to clean Terreon. If these chemicals come in contact with the Terreon surface, wipe them off immediately and rinse with soapy water. Avoid contact with harsh chemicals such as paint remover, bleach, acetone, etc. Avoid contact with hot pans and objects.

Repair Kits: Terreon repair kits are available. Contact your Bradley representative or distributor for part numbers and pricing.



Repair kits are made to order and have a shelf life of 30 days.

Brand Names: Use of brand names is intended only to indicate a type of cleaner. This does not constitute an endorsement, nor does the omission of any brand name cleaner imply its inadequacy. Many products named are regional in distribution, and can be found in local supermarkets, department and hardware stores, or through your cleaning service. It is emphasized that all products should be used in strict accordance with package instructions.

Cleaning and Maintenance Instructions for Bradstone

Bradstone is impervious to most chemicals and stains. Soap and dirt accumulations should be washed off with detergent cleaners. Abrasives and caustic cleaners are not recommended. An occasional waxing with automotive wax will make future cleaning even easier.

Cleaning and maintenance instructions for stainless steel

Material Description: Stainless steel is extremely durable, and maintenance is simple and inexpensive. Proper care, particularly under corrosive conditions, is essential. Always start with the simplest solution and work your way toward the more complicated.

Routine cleaning: Daily or as often as needed use a solution of warm water and soap, detergent, or ammonia. Apply the cleaning solution per the manufacturer's instructions and always use a soft cloth or sponge to avoid damaging the finish.

Stubborn Stains: To remove stains from stainless steel use a stainless steel cleaner and polish such as Ball® stainless steel cleaner or a soft abrasive. Always follow the manufacturer's instructions and apply in the same direction as the polish lines.

NOTICE! Never use ordinary steel wool or steel brushes on stainless steel. Always use stainless steel wool or stainless steel brushes.

Special Situations for Material

Fingerprints and Smears: To remove fingerprints or smears use a high quality stainless steel cleaner and polish in accordance with the manufacturer's instructions. Many of these products leave a protective coating that helps prevent future smears and fingerprints.

Grease and Oil : To remove grease and oil use a quality commercial detergent or caustic cleaner. Apply in accordance to the manufacturer's instructions and in the direction of the polish lines.

Precautions: Avoid prolonged contact with chlorides (bleaches, salts), bromides (sanitizing agents), thiocyanates (pesticides, photography chemicals, and some foods), and iodides on stainless steel equipment, especially if acid conditions exist.

NOTICE! Do not permit salty solutions to evaporate and dry on stainless steel.

The appearance of rust streaks on stainless steel leads to the belief that the stainless steel is rusting. Look for the actual source of the rust in some iron or steel particles which may be touching, but not actually a part of the stainless steel structure.

NOTICE! Strongly acidic or caustic cleaners may attack the steel, causing a reddish film to appear. The use of these cleaners should be avoided.

Brand Names: Use of brand names is intended only to indicate a type of cleaner. This does not constitute an endorsement, nor does the omission of any brand name cleaner imply its inadequacy. Many products named are regional in distribution, and can be found in local supermarkets, department and hardware stores, or through your cleaning service. It is emphasized that all products should be used in strict accordance with package instructions.

Soap Valve — Liquid — S09-007S

Parts List

Item	Part No.	Description	Attaching Parts S09-007S	
			Qty	
1	118-025	Valve Body	1	
2	110-007	Packing Nut	1	
3	135-001L	Spring	1	
4	125-001BU	Washer	1	
5	119-028	Plunger	1	
*	161-014	Nut	1	
*	124-001D	Washer	2	
*	142-002AH	Washer - Stainless Steel	1	

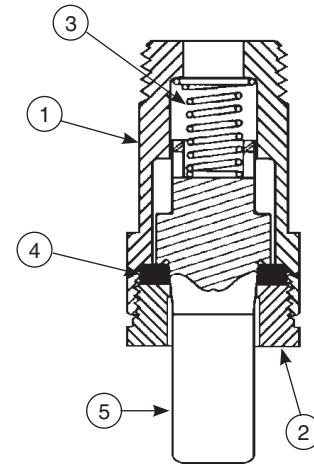

* Not Illustrated

This valve delivers a measured amount of soap with each upward stroke. The soap dispenser has been standard on washfountains since 1983 and is not well-suited for very thick lotion soaps.

NOTICE! Lotion soap will clog liquid soap valves. Use only lotion soap valves with lotion soap.

Soap Valve — Lotion — S09-057S

Parts List

Item	Part No.	Description	Valve Assembly S09-057	Attaching Parts S09-057S
			Qty	
1	124-001D	Washer	—	1
2	110-057	Nut	—	1
3	125-001AN	Stopper	—	1
4	159-114	Reinforcing Plate	—	1
5	124-001AT	Washer	—	1
6	160-176	Screw	—	1
7	S09-040	Valve	1	1
8	S53-045	Adaptor	1	1

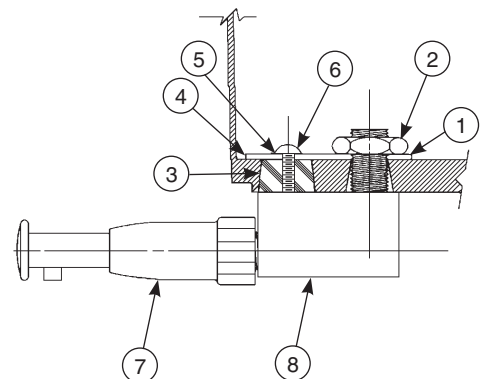

Soap Valve — Powdered — S09-010A

Parts List

Item	Part No.	Qty	Description
1	160-069	1	Screw, 1/4-20 RD
2	142-002X	1	Washer, 1/4 Split-Lock
3	S62-002	1	Agitator / Slide Assy.
4	192-004	1	Lever - Powdered Soap

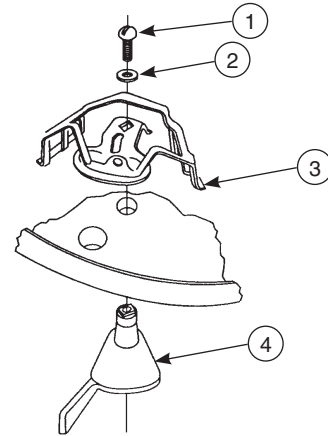

Reducer plugs are available for use with fine granulated soap to reduce the flow.



Valves can be changed from powdered to liquid by plugging the innermost, or "bearing" hole with rubber plug, part number 125-001AK. To change from liquid to powdered, the plug must be removed. If none is present, it will be necessary to drill out the bearing hole with a 1/2" or 5/8" drill. The plastic container configuration forms a natural template for locating the bearing hole.

Soap Maintenance Tips

Soap Recommendations

Quality soap dispensers require good quality soap and periodic maintenance to properly operate. Bradley soap dispensers will provide dependable, consistent operation over the long term when soap with reasonable viscosity and pH levels are used and when a minimal amount of periodic maintenance is performed on the valves.

Soap thickness is determined by a measurement called viscosity. Soap viscosity should be between 100 cps (centerpoise) and 2500 cps for all Bradley soap dispensers. Thinner soaps are perceived by the users as being "watered down" so users tend to take more than they need, resulting in waste. **Thick soaps flow slower and inhibit the "flushing" action of the valves, which allows the soap to congeal in the valve and cause clogs.**

The pH (acid) level of the soap should be in the range of 6.5 to 8.5. More acidic soaps (pH levels lower than 6.5) will corrode metal parts (even stainless steel!!) and degrade rubber and plastic components. They will also cause skin irritation. **Most inexpensive soaps (typically the pink lotion type) fall into this acidic category and will eventually cause valve failure and metal corrosion.** Base soaps (pH levels higher than 8.5) will cause swelling or degradation of rubber and plastic parts and skin irritation.

Generally, any quality soap meeting the viscosity and pH guidelines above will work well with Bradley soap dispensers. PCMX or Isopropanol based antibacterial soaps (within viscosity and pH limits) will also work with Bradley dispensers. Soaps satisfying these basic guidelines will provide consistent flow and reduce clogs.

Most soap dispenser problems are caused by soap that is too thick or corrosive, or by a lack of maintenance. Many soaps come in concentrate form which must be diluted with water. Often, the soap is improperly diluted or used straight out of the bottle, which causes clogging and valve failure. If proper soap is being used, valves that have never been cleaned are usually the source of dispensing problems. Bradley has entered into an agreement with Champion Brand Products to provide additional customer service for purchasers of our dispensers regarding soap issues. They are very helpful and can get to the bottom of almost any soap dispenser related problem. They also sell an excellent "Bradley approved" soap. Please see **Soap Instruction Sheet 215-1286** for details about soap valve cleaning or how to contact Champion. With proper maintenance and soap, Bradley dispensers will provide long term, trouble free operation.

Soap Dispenser Maintenance Instructions

Bradley soap dispensers will provide dependable, consistent operation over the long term when the proper soap is used and when a minimal amount of periodic maintenance is performed on the valves. Valves must be maintained (cleaned) to function properly.

To ensure proper operation of your soap dispenser, follow these instructions:

- Once per month, unscrew valve from reservoir and soak it for 30 minutes in hot water.
- Push valve at least 20 times while it is soaking.
- Flush soap reservoir with hot water while valve is soaking.

In cases of extreme clogging, the valve should be disassembled and the parts should be soaked in hot water or cleaning solution to restore proper functioning. Soap dispensers that will not be used for extended periods of time (schools during summer break, etc.) should be drained, cleaned and left empty until put back into service. Soap left on the outside of dispensers can cause discoloration and corrosion of the reservoir (even on stainless steel units). All soap should be wiped or scrubbed off daily, then the outside of the dispenser should be rinsed with clear water and dried with a soft cloth.

Sprayheads — Standard w/Neoprene Spray Ring Grommet



Repair kit does not include sprayhead grommet. Order as a separate item.

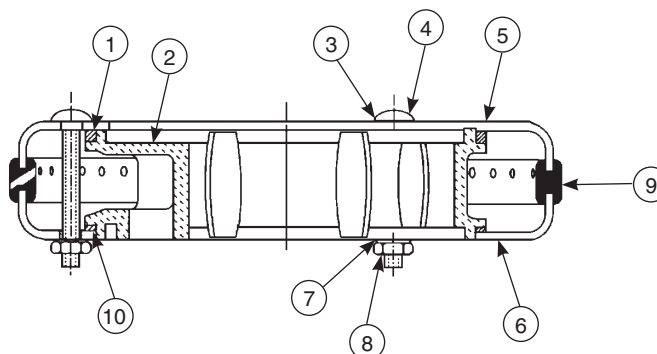
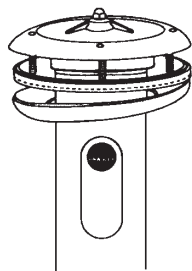

Parts List

Item	Part No.	Description	Sprayhead Assembly S05-054A	Repair Kit S45-051
			Qty	
1	125-001DE	Neoprene Washer - Top	1	1
2	139-031	Sprayhead Manifold	1	—
3	124-001AL	Washer	3	4
4	160-211	Carriage Bolt	3	4
5	115-061	Sprayhead - Top	1	—
6	116-008	Sprayhead - Bottom	1	—
7	124-001AT	Washer	3	4
8	161-025	Nut	3	4
9	124-020C	Sprayhead Grommet - Circle	1	—
10	125-001DF	Neoprene Washer - Bottom	1	1

Sprayhead Troubleshooting

Problem	Possible Cause	Solution
Water splashes over the rim of the bowl.	Foreign matter has reduced the size of the sprayhead slots, causing greater pressure at the open slots.	Clean the sprayhead: <ol style="list-style-type: none"> Disassemble the sprayhead and dislodge any dirt, lime build-up and foreign debris with a wire brush. Sprayheads with rubber grommet spray rings may be cleaned by rubbing a coin over the grommet. Throttle down the volume control (water spray should strike the bowl without splashing outside of the bowl).
Water flow diminishes from the sprayhead.	Strainer portion of the stop-strainer-check valve is plugged.	Remove and clean the strainer screen from the stop-strainer-check valve.



The sprayhead shown above includes a perforated neoprene spray ring grommet that is self-cleaning. The water pressure flexes the spray holes which slows accumulation of foreign matter and tends to "break loose" any such deposits that may have accumulated.

I.R. Module Assembly Components (S50-344)

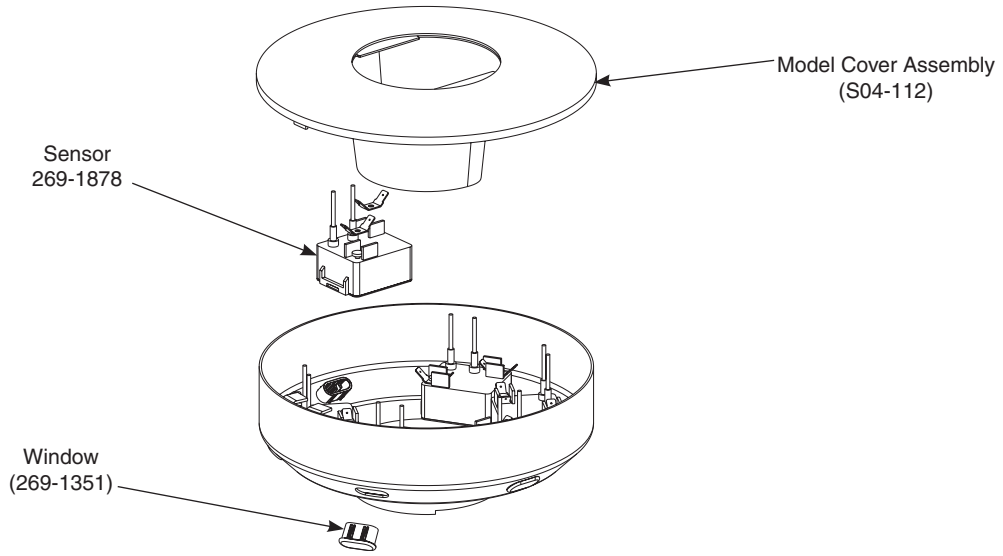

Troubleshooting Adaptive IR

There is a LED diagnostic light built into the small black box housing the circuitry for the sensor. Below is a list of what the signals from the LED mean. Use this list to troubleshoot the sensor.

Problem	Cause	Solution
LED not illuminated.	No power is getting to the sensor.	Check for power at the 110 VAC wall outlet and from the wires from the 24 VAC transformer. If there is 110 VAC power at the wall outlet, but no power from the transformer, touching leads from the transformer while plugged in or a power surge may have burned out the transformer. Add surge protection at the outlet if a power surge is suspected and replace the transformer. If 24 VAC power is being supplied from the transformer, check for loose wire connections and check connections against the wiring diagram.
Fast blink	Sensor is detecting something in it's view and water should be on (power is being sent to the solenoid)	<p>If the sensor is blinking fast, the water is turning on and there is nothing in the detection area, disconnect the power for at least 30 seconds. This will allow the sensor to loose it's memory and be reset. Reconnect the power and wait 2 full minutes to allow the sensor to relearn the environment before attempting to activate. The sensor may take up to 8 minutes to readjust if it activated during those 2 minutes.</p> <p>If the condition persists, make sure the LEDs at the ends of the sensor cables are pushed all the way in to the backs of the lenses.</p> <p>If the sensor is blinking fast and the water is not turning on, go through the troubleshooting guide for the solenoid.</p>
Slow blink	Sensor is detecting something in it's view and the water is off (power is not being sent to the solenoid).	The sensor has detected a stationary object in its view for more than 30 seconds and shut off power to the solenoid valve. Remove the object, if it is still in the bowl, and reset the sensor as explained above.
Blinking SOS (3 short, 3 long, 3 short)	The sensor has detected an overload condition and shut down to protect it's circuits.	Check connections against the wiring diagram. This condition usually means the solenoid valve is not properly wired. After correcting any wiring error, it will be necessary to reset the sensor as explained above.

If you need further assistance, please call your local Bradley representative. Please call us at 1-800-Bradley if you need the name and telephone number of your local Bradley representative.

Solenoid Valve Repair Parts

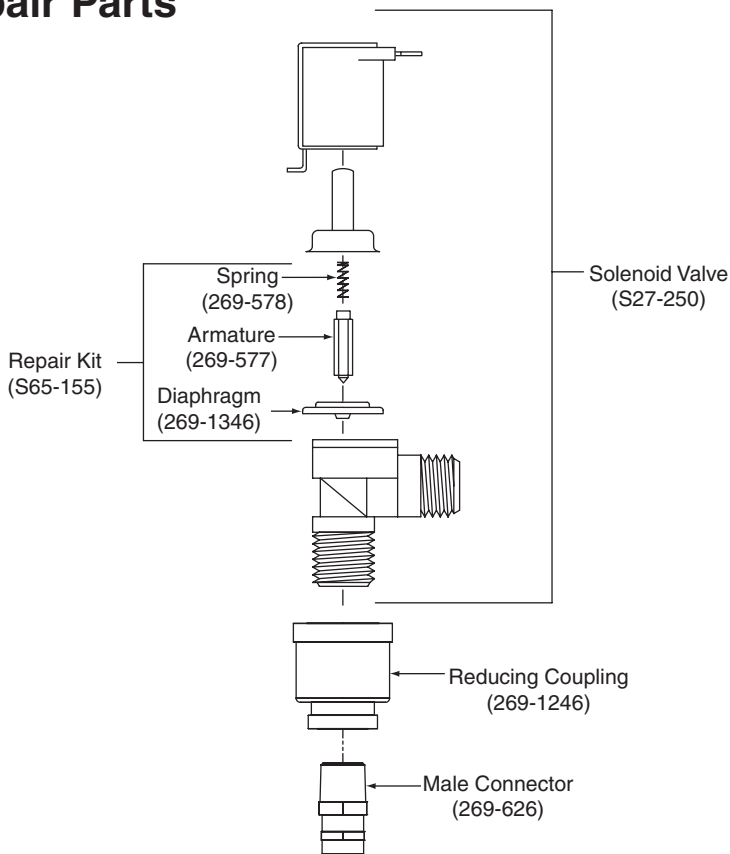

Solenoid Valve Troubleshooting

IMPORTANT! Make sure there is electrical power going to the transformer and there are 24 volts coming from the transformer.

CAUTION! Turn off electrical and water supplies to unit before troubleshooting.

Problem	Cause	Solution
Sprayhead drips or fails to shut off	Debris is trapped between the diaphragm and the valve seat.	<p>Remove debris between diaphragm and the valve seat.</p> <ol style="list-style-type: none"> 1. Remove the four screws that secure the clamping plate to the valve body. Be careful not to lose the armature or spring 2. Remove the diaphragm and clean it gently but thoroughly. Hold the diaphragm up to a light and find the small hole which is located about halfway between the inner diameter and the outer diameter. Make sure the hole in the diaphragm is not plugged. 3. Reassemble the valve in reverse order and test with power from the transformer.
Sprayhead fails to turn on.	A failed coil for the valve or loose electrical connection to the terminal.	<p>Test the valves and check the wiring connections.</p> <ol style="list-style-type: none"> 1. Disconnect the wires from the IR module to the transformer and solenoid 2. Connect the wire from the transformer to the solenoid valve. Both transformer wires should now be connected to the solenoid valve which should turn on immediately and run continuously. <ul style="list-style-type: none"> • If the solenoid valve does not turn on and you have made sure that there is 24-volt power coming from the transformer, you know that the solenoid has failed and will need to be replaced. 3. After replacing the solenoid valve (if necessary), reconnect the wire from the transformer to the IR module. Test the solenoid valve again. <ul style="list-style-type: none"> • If the solenoid valve does not turn on, check the wiring for proper connections. If it still fails to turn on, the problem may be in the sensor. Refer to the Troubleshooting Infrared instructions on page 15 and follow the sensor troubleshooting procedure outlined there.

Stop, Strainer and Check Valve Parts

Parts List S60-003 Stop, Strainer, and Check Valve

Item	Part No.	Qty.	Description
1	118-039	1	Valve Body - Brass
1	118-039A	1	Valve Body - Plated
2	160-131	1	Set Screw
3	S21-014	1	Stop Assembly - Celcon
3	S21-026	1	Stop Assembly - Brass
*4	156-006	1	Strainer
*5	124-001BV	2	Fiber Washer
*6	153-068	2	Plug - Brass
7	129-007	1	Tail Piece - Brass
7	129-007A	1	Tail Piece - Plated
8	110-005	1	Tail Piece Nut - Brass
8	110-005A	1	Tail Piece Nut - Plated
*9	124-001AF	1	Tail Piece Washer
*10	135-001AB	1	Spring
*11	S21-015	1	Check Assembly

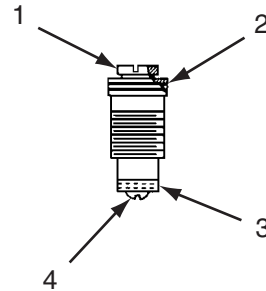
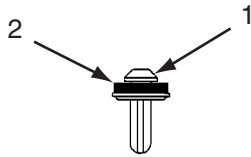
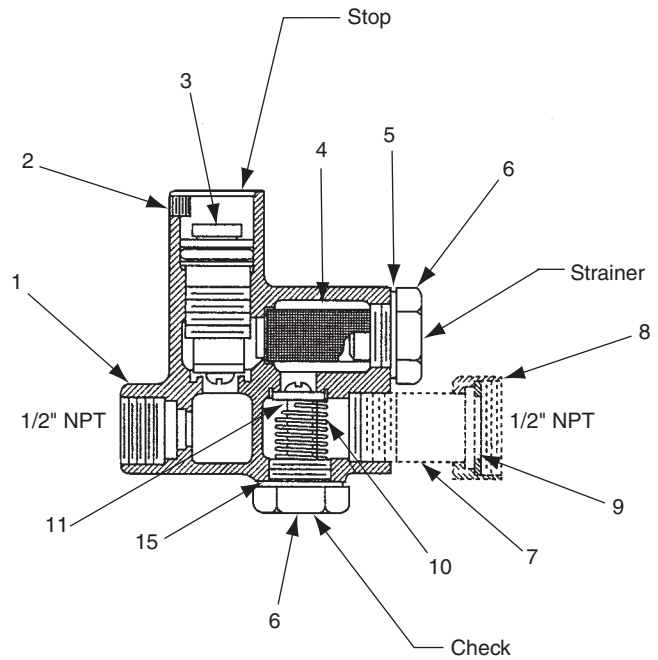

Parts List S21-015* Check Assembly

Item	Part No.	Qty.	Description
1	119-091	1	Plunger
*2	125-001BB	1	Washer

Parts List S21-014 Standard Celcon Core

Item	Part No.	Qty.	Description
1	119-057	1	Valve Core
*2	125-001AW	1	"O" Ring
*3	125-001L	1	Bibb Washer
4	160-164	1	Screw

* S45-050 Repair Kit Includes these parts

Check Valve Troubleshooting

Problem	Solution
Water just dribbles or does not flow from sprayhead.	<ol style="list-style-type: none"> 1. Turn off water supplies to fixture. 2. Inspect check valves for proper installation. 3. Open the stops and clean the strainers, if necessary.
Water sprayhead delivers all hot or cold water.	<ol style="list-style-type: none"> 1. Turn off water supplies to fixture. 2. Inspect check valves for proper installation. 3. Open the stops and clean the strainers, if necessary. 4. Inspect mixing valve for proper installation (see Vernatherm valve on page 25).

Valve Assembly Parts

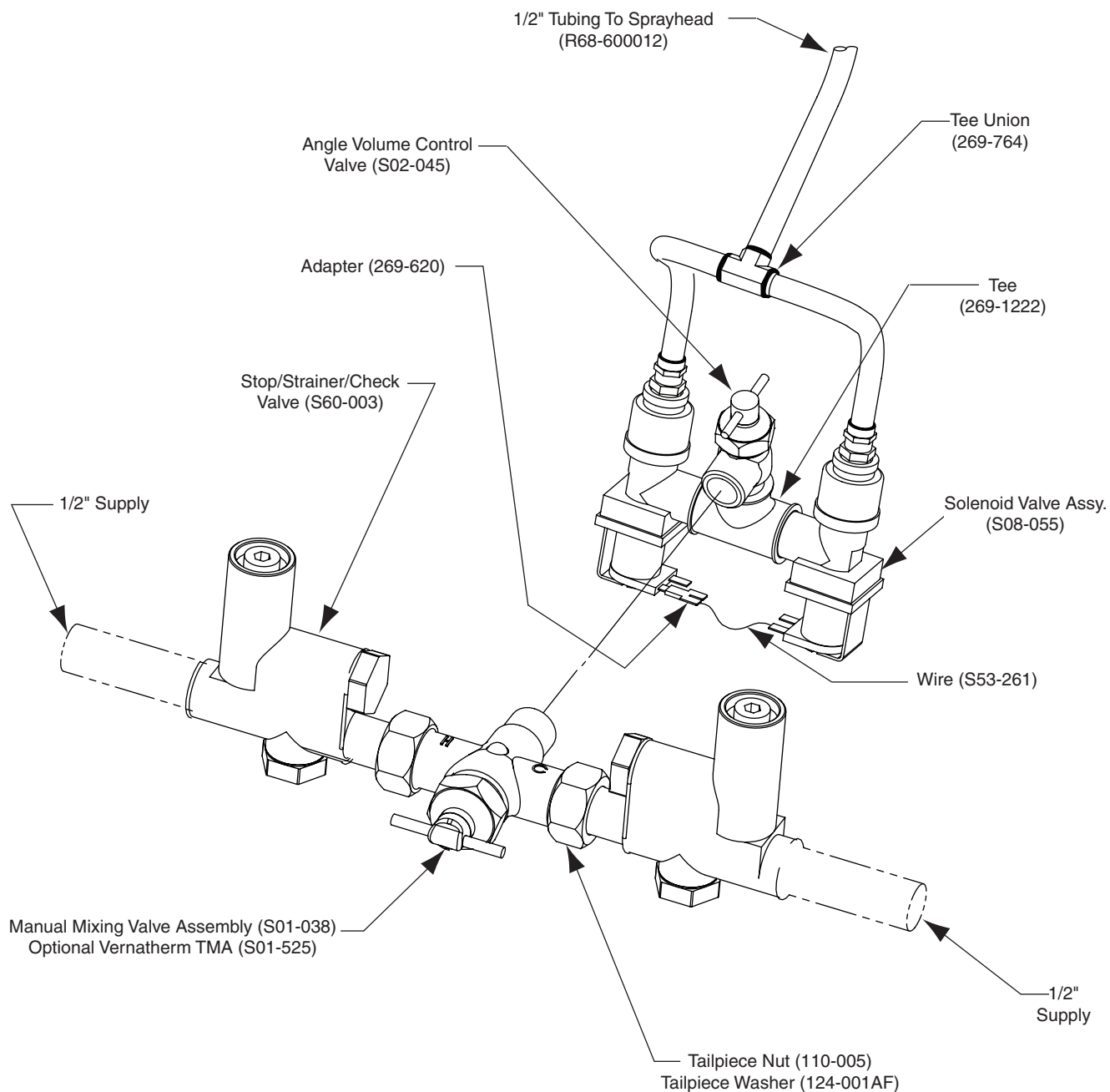

Manual Mixing Valve Repair Parts

Item	Part No.	Description	Valve Assembly S01-038	Valve and Tailpieces S01-038S	Repair Kit S45-197
			Qty.		
1	118-034	Mixing Valve Body - Brass	1	1	—
1	118-034A	Mixing Valve Body - Chrome	—	—	—
2	124-001BD	Fiber Washer	1	1	1
3	125-001BC	O-Ring	1	1	1
4	119-059	Mixing Valve Core	1	1	1
5	152-038	Roll Pin	1	1	1
6	121-016	Bonnet - Brass	1	1	1
6	121-016A	Bonnet - Chrome	—	—	—
7	160-197	Screw - Brass	1	1	—
7	160-189	Screw - Stainless Steel	—	—	—
*	129-007	Tailpiece - Brass	—	2	—
*	110-005	Tailpiece Nut - Brass	—	2	—
*	129-007A	Tailpiece - Chrome	—	—	—
*	110-005A	Tailpiece Nut - Chrome	—	—	—
*	124-001AF	Tailpiece Washer	—	2	2

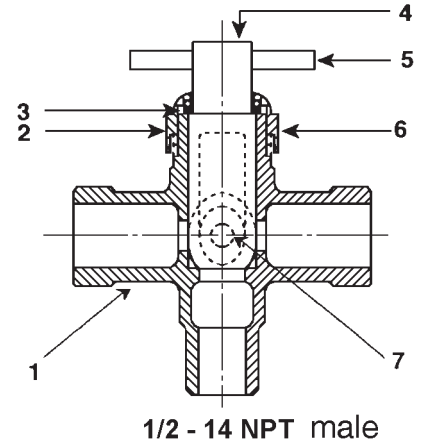

Volume Control Valve Repair Parts

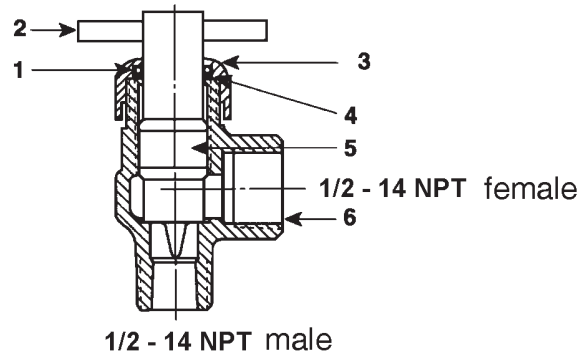

Item	Part No.	Description	Brass Valve S02-045	Repair Kit S45-198
			Qty.	
1	125-001BC	O-Ring	1	1
2	152-038	Roll Pin	1	1
3	121-016	Bonnet	1	1
3	121-016A	Bonnet	—	—
4	124-001BD	Fiber Washer	1	1
5	119-060	Valve Core	1	1
6	118-033	Valve Body	1	—
6	118-033B	Valve Body	—	—

Vernatherm Thermostatic Mixing Valve (S01-525) Parts List — Repair Kit S65-259

Item	Part No.	Qty.	Description
4	S39-413	1	Thermostat
6	125-001BX	1	O-Ring
7	125-157	1	O-Ring

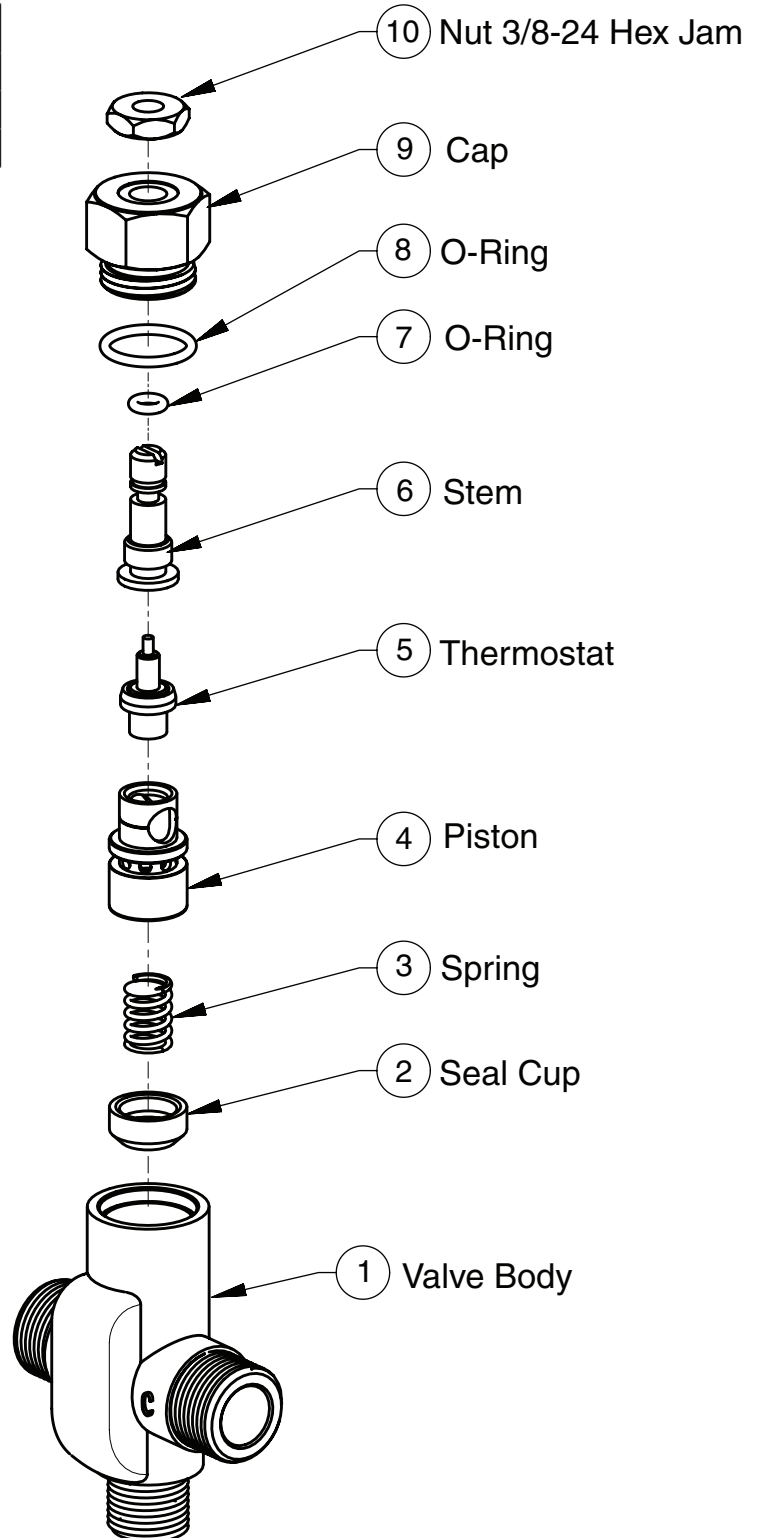

Thermostatic Mixing Valve Troubleshooting

Before attempting to troubleshoot the valve or disassemble the components, check for the following conditions:

- If stop valves are used, make sure that they are fully open.
- Make sure that the hot and cold inlet pipes are connected properly, and that there are no cross-connections or leaking stop valves.
- Check the hot water heater output to make sure that it is at least 20° F above the set temperature.



Be sure to close the appropriate shut-off valves prior to disassembly of the valve and reopen the valves after inspection and repair is complete.

Problem	Cause	Solution
External leaks.	Damaged O-rings.	Replace O-rings where necessary. For replacement of the O-rings, contact your Bradley representative and ask for Repair Kit (part number S65-259).
Improper water temperature or temperature fluctuation.	Thermostat is slowly failing or not working at all.	Check the thermostat for proper operation. <ol style="list-style-type: none"> 1. At room temperature (80° F or less) remove cap and thermostat. 2. Place thermostat into container with 115° F water. The pushrod should pop out of the thermostat approximately 1/10". 3. If thermostat pushrod does not pop out, the thermostat must be replaced. Contact your Bradley representative and ask for Repair Kit (part number S65-259).
	Valve temperature is not properly set.	Adjust the temperature.
Limited water flow.	Dirt and debris have built up in the valve or strainer.	Check the valve's piston for free and smooth movement, <ol style="list-style-type: none"> 1. Remove the valve's cap and thermostat 2. Push down on the piston with your finger (the piston should move freely). If the movement is not as it should be, the piston needs to be cleaned. Follow the method outlined below for cleaning the piston and valve body: <ul style="list-style-type: none"> • Remove the thermostat. • Lift the piston out with a needle-nose pliers and remove the spring. • Any cleaner suitable for brass and stainless steel may be used (if cleaning with suitable cleaner is not sufficient to remove debris, a 400-grit sandpaper may be used to polish and hone the piston and valve body). • Snap spring into piston (will detent) and reassemble into the valve body. • Retest the piston. 3. If, after a thorough cleaning, the piston does not move freely, the piston must be replaced. Contact your Bradley representative and ask for Repair Kit (part number S65-259).