

WF2605

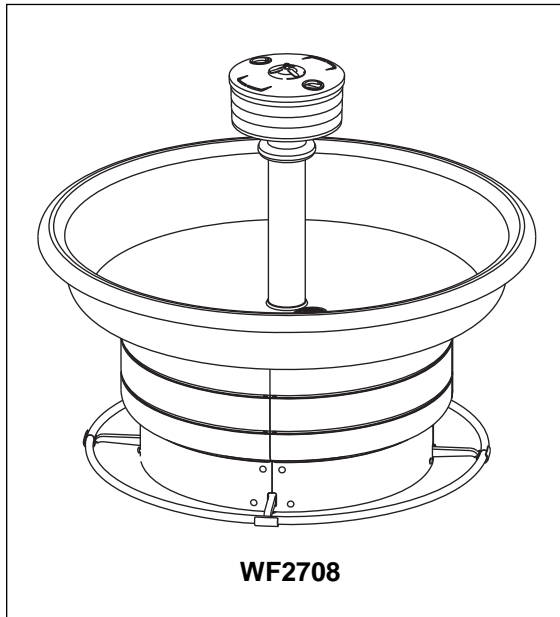

WF2708



**IMPORTANT**

**Read this entire installation manual to ensure proper installation.**

**Flush all the water supply lines before making connections.**

**Main water supply to the unit should be ON at all times.**

**This installation manual and parts list should be filed by the owner's maintenance department.**

# Installation Instructions

**WF2605, WF2608 Terrazzo**  
**WF2705, WF2708 Stainless Steel**

## Classic Circular 36"/54" Washfountain with Foot Control

### Table of Contents

Pre-Installation Information .....	2
Circular Washfountain Dimensions .....	3-4
Rough-In Specifications .....	5-6
Drain Rough-In Specifications .....	7
Pedestal Mounting and Assembly .....	8
Bowl and Pedestal Assembly and Mounting .....	9
Drain Spud Installation .....	10
Supplies w/Optional Soap Dispenser (A/O drains) ..	11-12
Supplies w/Optional Soap Dispenser (B/H drains) ..	13-14
Installing the Valve Assembly .....	15
Installing the Operating Rod .....	16
Soap Valve Maintenance and Repair Parts ..	17-18
Check Valve Troubleshooting .....	17
Stop, Strainer and Check Valve Repair Parts .....	19
Sprayhead Troubleshooting/Repair Parts .....	20
Foot Valve Breakdown and Repair Kit .....	21
Manual Mixing Valve Repair Parts .....	22
Volume Control Valve Repair Parts .....	23
Vernatherm™ Mixing Valve Maintenance ..	24-26
Cleaning and Maintenance Instructions .....	27-28

UPC Certified



P.O. Box 309, Menomonee Falls, WI 53052-0309  
 TEL. 1-800-BRADLEY FAX 262-251-5817  
<http://www.bradleycorp.com>

## Pre-Installation Information

### Operation

Stepping on the foot rail allows the user to activate a valve starting the flow of water.

### Supplies required for installation:

- (8) 1/2" lag bolts, screws or other fasteners to anchor washfountain pedestal to floor
- 1" hot and cold water supply lines and fittings (refer to rough-ins on pages 5-6)
- Reducing fittings and 1/2" nom. copper tubing supply lines for types with supplies from above
- 2" drain lines and fittings (refer to rough-ins on pages 5-6)
- Standard 2" P-trap (refer to rough-ins on page 7, special vented trap supplied for B and H type)
- Pipe sealant and plumber's putty
- 1-1/2" vent pipe on types vented through washfountain column (refer to page 4 for lengths required)

*NOTE: Supply lines for one or two washfountains should be 1"; for three washfountains 1-1/4"; for more than three washfountains pipe size should increase proportionally. Vent pipe to be 1-1/2" on models vented through Washfountain.*

#### **Bradley Classic Washfountain Warranty Information**

Product warranties may be found under "Product Information" on our website at [www.bradleycorp.com](http://www.bradleycorp.com)

## Circular Washfountain Dimensions

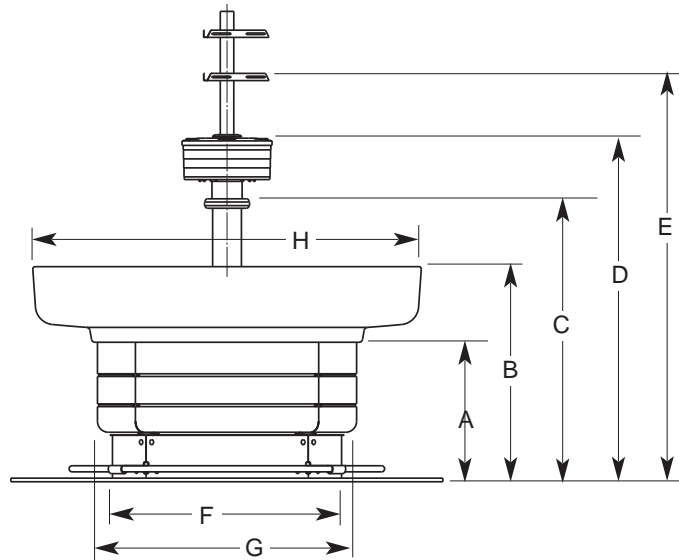

Approximate Dimensions in Inches*									
Material	Size	A	B	C	D	E	F	G	H
Terrazzo	54	19	29-1/4	39-1/8	47-5/8	56	32	36	54
Stainless Steel	54	19	28	37-3/8	45-7/8	54-1/4	32	36	54
Terrazzo	36	19	29-1/4	35-5/8	44-1/8	52-1/2	21	25	36
Stainless Steel	36	19	28	33-7/8	42-3/8	50-3/4	21	25	36

\* Juvenile height (Terrazzo only): Subtract 4" from dimensions A through E for juvenile height.

Approximate Dimensions in Millimeters*									
Material	Size	A	B	C	D	E	F	G	H
Terrazzo	1372	483	743	994	1210	1422	813	914	1372
Stainless Steel	1372	483	711	949	1165	1378	813	914	1372
Terrazzo	914	483	743	905	1121	1334	533	635	914
Stainless Steel	914	483	711	860	1076	1289	533	635	914

\* Juvenile height (Terrazzo only): Subtract 4" from dimensions A through E for juvenile height.

## Length of Tie Pipe Required for Vent Through Washfountain Column

Type	Pipe Length
54" Less Soap Dispenser	21-1/2" (546mm)
36" Less Soap Dispenser	18" (457mm)
54" With Soap Dispenser	30" (762mm)
36" With Soap Dispenser	26-1/2" (673mm)
54" Less Soap Dispenser With Towel Dispenser	55-1/2" (1410mm)
36" Less Soap Dispenser With Towel Dispenser	52" (1321mm)
54" With Soap Dispenser With Towel Dispenser	48" (1219mm)
36" With Soap Dispenser With Towel Dispenser	44-1/2" (1130mm)
54" With Cube Adapter	32" (813mm)
36" With Cube Adapter	28-1/2" (724mm)
54" With Cube Adapter With Towel Dispenser	50" (1270mm)
36" With Cube Adapter With Towel Dispenser	46-1/2" (1181mm)
54" With Cube Adapter And Soap Dispenser	40" (1016mm)
36" With Cube Adapter And Soap Dispenser	36-1/2" (927mm)

*NOTE: Drain must be connected with 2" schedule 40 welded wrought iron pipe, minimum, to provide lower support for this installation. Vent or support pipe must be of the same material in 1-1/2".*

## Rough-In Specifications

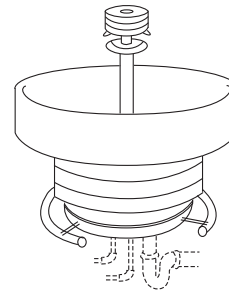
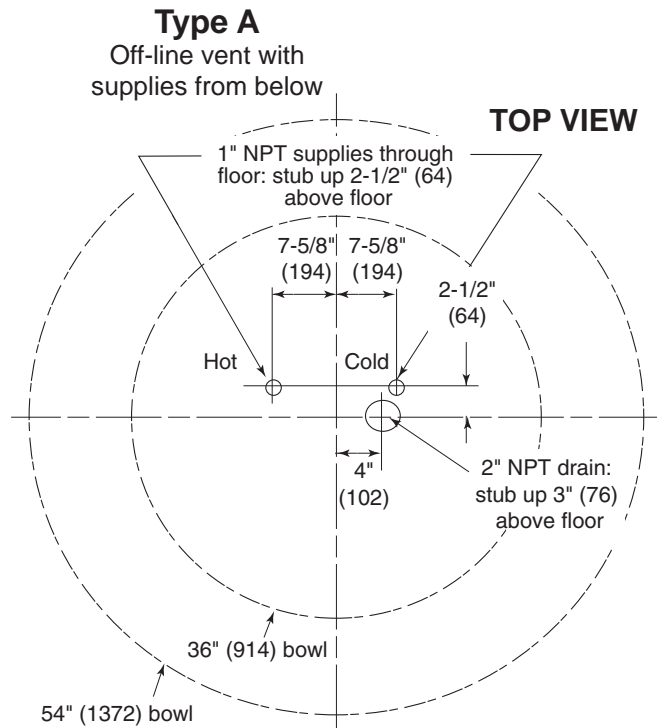

**NOTE:** UPC and IPC restrict the vertical distance from the fixture outlet to the trap weir to not more than 24". Check state and local codes for variances.

**Type B**  
 Centrally rising vent with supplies from above

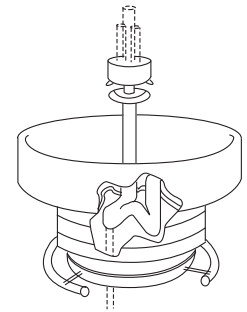
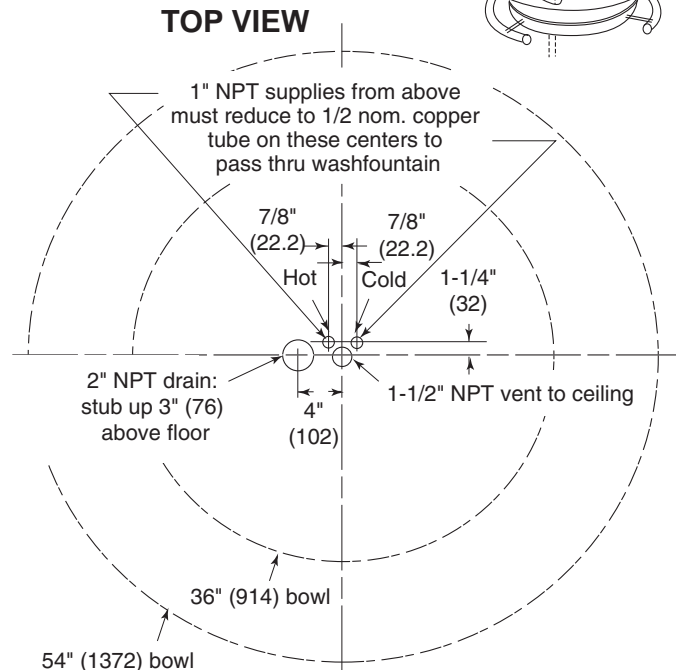

**Rough-In Notes:**

1. All pipes and fittings not furnished by Bradley are shown in broken lines.
2. Supply lines for one to two washfountains should be 1"; for three washfountains 1-1/4"; for more than three washfountains, pipe sizes should be increased proportionately.
3. Overhead supplies must be reduced to 1/2" copper tube to pass through support tube.
4. Check valve inlets are 1/2" NPT.
5. Dimensions shown in parentheses are millimeters.

## Rough-In Specifications ... Continued

**Type O**  
 Off-line vent with  
 supplies from above

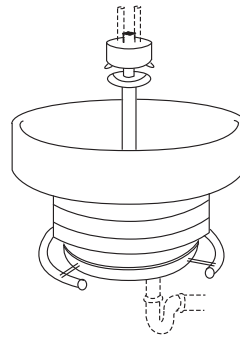
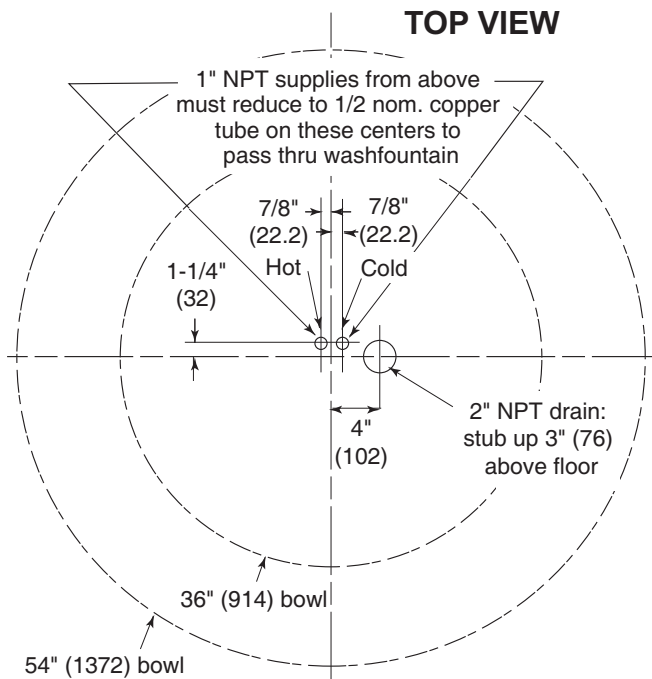

**NOTE:** UPC and IPC restrict the vertical distance from the fixture outlet to the trap weir to not more than 24". Check state and local codes for variances.

**Type H**  
 Centrally rising vent with  
 supplies from below

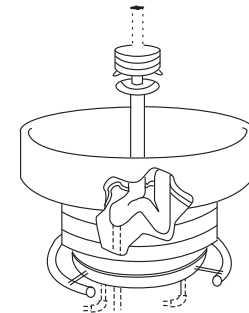
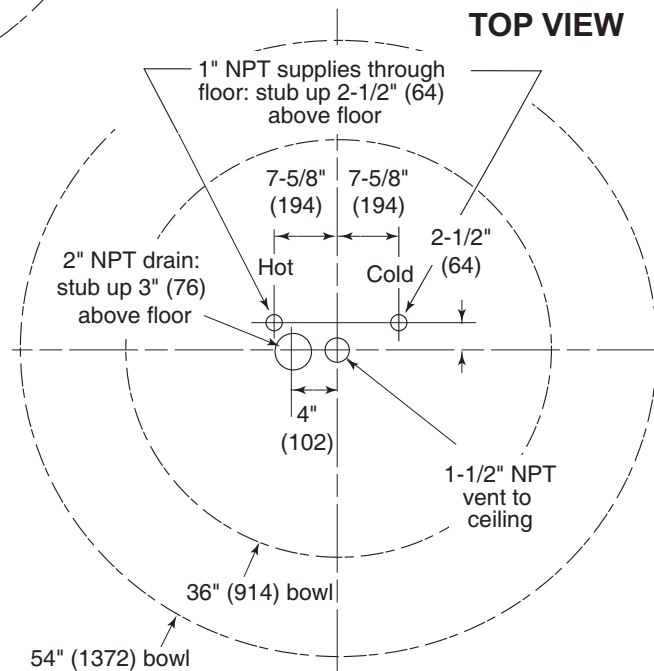

**Rough-In Notes:**

1. All pipes and fittings not furnished by Bradley are shown in broken lines.
2. Supply lines for one to two washfountains should be 1"; for three washfountains 1-1/4"; for more than three washfountains, pipe sizes should be increased proportionately.
3. Overhead supplies must be reduced to 1/2" copper tube to pass through support tube.
4. Check valve inlets are 1/2" NPT.
5. Dimensions shown in parentheses are millimeters.

# Installation Instructions

## Step 1: Rough-In of Drain & Supplies

1. Rough in supply and drain piping as required for your installation (see pages 5-6 for rough-ins of the optional installations).
2. Assemble the drain to the dimension shown in Figure 1 and Table 1 for bowl size of the Washfountain you are installing.

*NOTE: All piping shown in dotted lines to be supplied by the installer. Compliance and conformity to local codes and ordinances is the responsibility of the installer.*

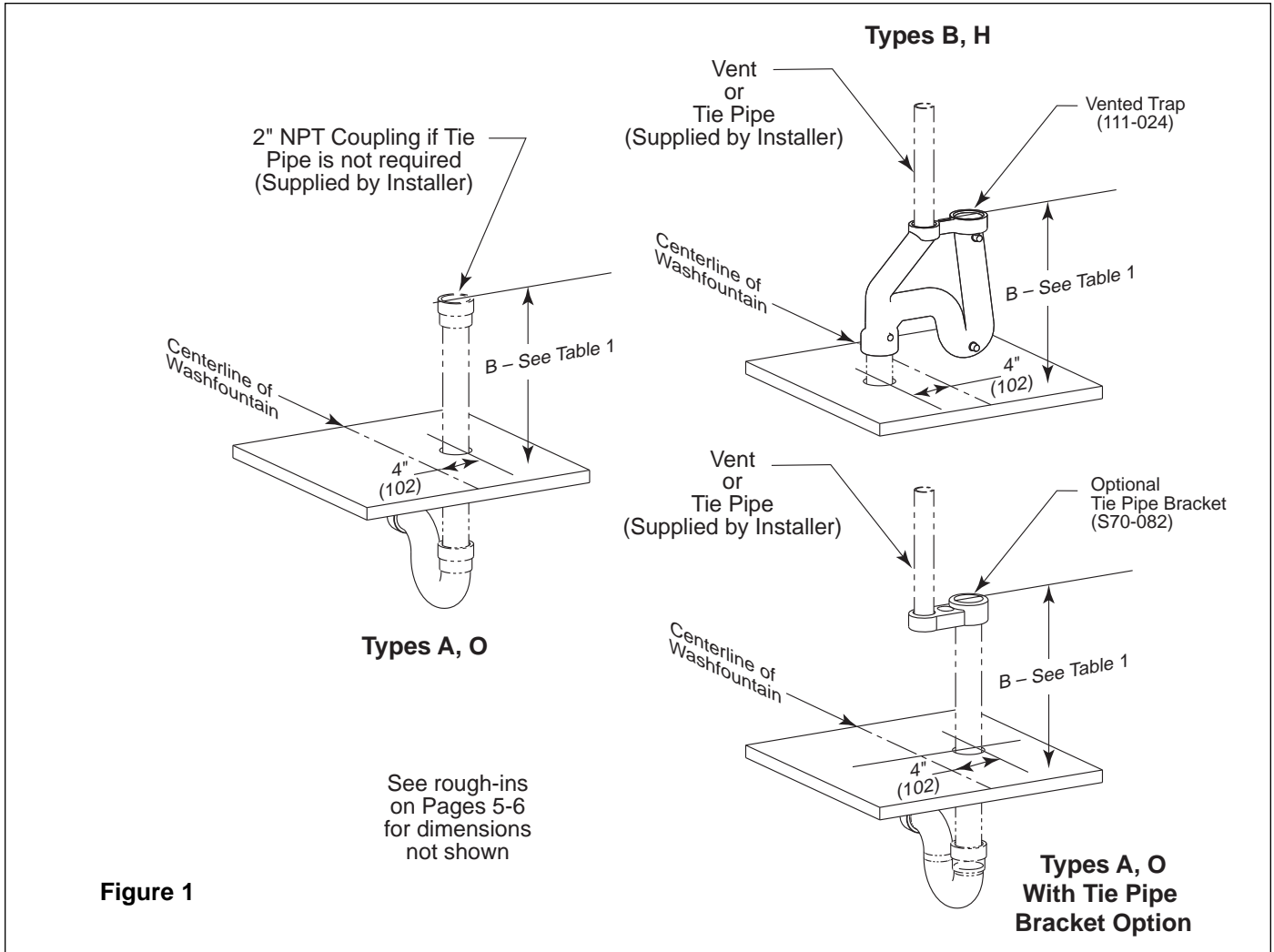

**Table 1 — “B” Trap Dimensions**

Material	Size	Dim	Standard Height	Juvenile Height
Terrazzo	54"	B	18-5/8" (473mm)	14-5/8" (371mm)
Stainless Steel	54"	B	17" (432mm)	N/A
Terrazzo	36"	B	18-5/8" (473mm)	14-5/8" (371mm)
Stainless Steel	36"	B	17-3/8" (441mm)	N/A

## Installation Instructions *continued* . . .

### Step 2: Assembling the Pedestal

1. Assemble the leg and scuff base panels with the 5/16" carriage bolts and nuts provided (Figure 2).
2. Attach the pedestal frame members with the 5/16" stove bolts and nuts provided (Figures 2 and 3).
3. Add the foot levers and operating cross to the pedestal assembly (Figures 2 and 4).
4. Press the foot rail into place with a rolling motion. The joint of the foot rail should be placed in the clevis of one of the foot valves (Figure 2).

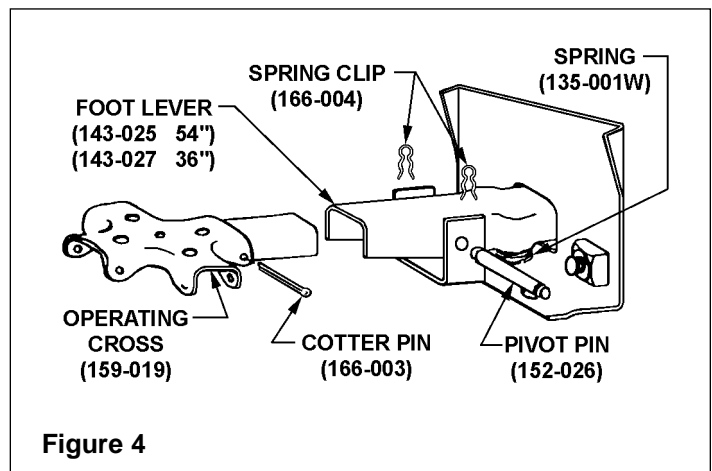
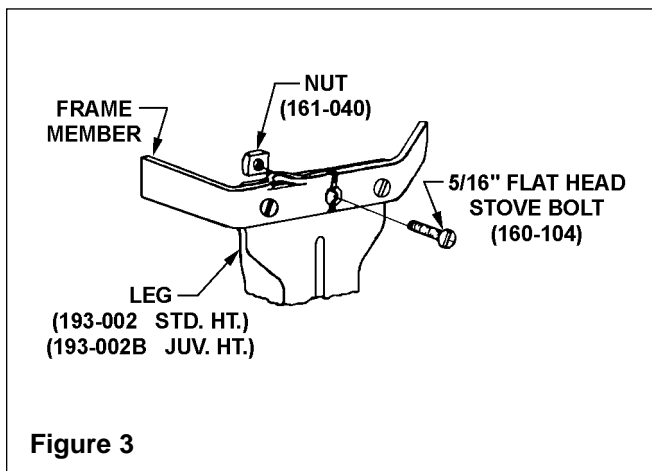
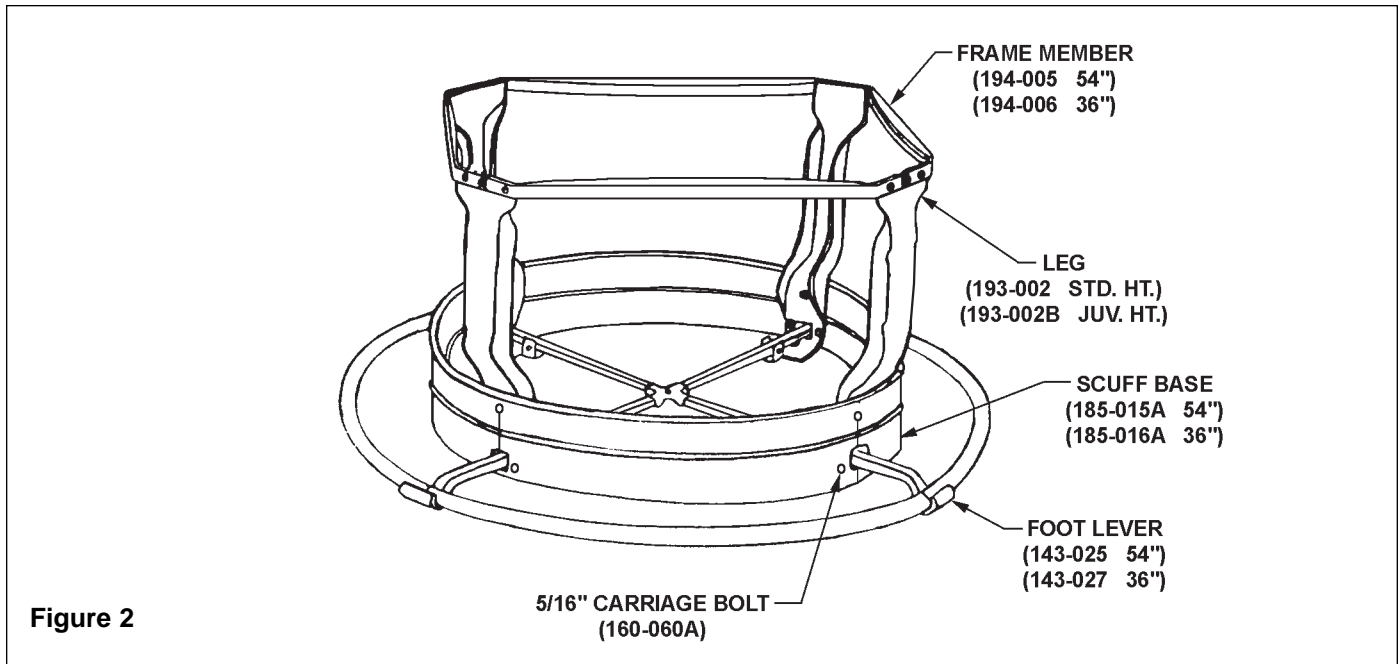



## Installation Instructions *continued* . . .

### Step 3: Bowl and pedestal assembly and mounting

- ⚠ IMPORTANT: FOR PROPER DRAINAGE, THE BOWL AND PEDESTAL MUST BE LEVEL WHEN THEY ARE SECURED TO THE FLOOR .**
- ⚠ WARNING: USE SUITABLE LIFTING EQUIPMENT TO POSITION THE BOWL AND PEDESTAL ASSEMBLY. HANDLE WITH CARE! FAILURE TO DO SO COULD RESULT IN SERIOUS PERSONAL INJURIES.**

#### STAINLESS STEEL BOWL:

1. Place the bowl on the pedestal using suitable lifting equipment.
2. Fasten the bowl to the pedestal with the four flat head stove bolts provided. Place the bowl clip inside the pedestal leg (see Figure 5).
3. Position the bowl and pedestal assembly so that the bowl drain is in line with the trap or drain line (see Figure 6 at right and figure 7 on page 10).
4. Screw the drain spud part of the way into the drain to ensure correct alignment (see Figure 7 on page 10).
5. Anchor the pedestal assembly to the floor and wall with suitable anchors/fasteners (supplied by installer).

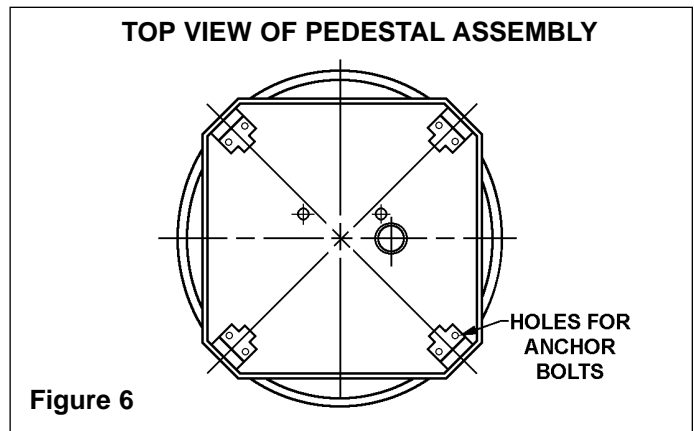
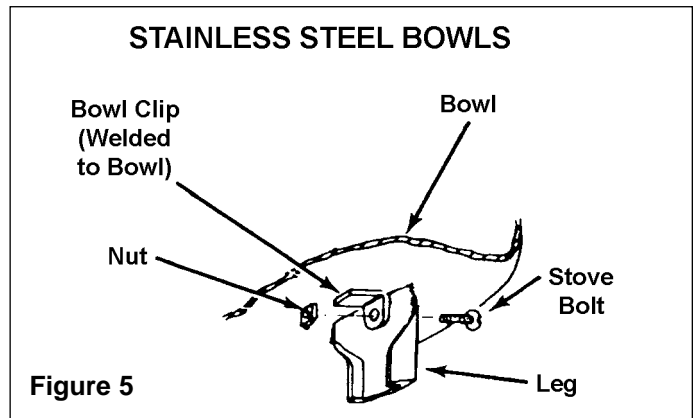

#### TERRAZZO BOWL:

- ⚠ CAUTION: Bowl Surface is smooth. Use suitable lifting equipment to position the bowl and pedestal assembly. Handle with CARE!**

1. Place the pedestal assembly as shown in Figure 6.
2. Place the bowl on the pedestal using suitable lifting equipment.
3. Screw the drain spud part way into the drain to ensure correct alignment (see Figure 7).
4. Anchor the pedestal assembly to the floor with suitable anchors/fasteners (supplied by installer).

## Installation Instructions *continued* . . .

### Step 4: Installing drain spud in bowl

*NOTE: Seal between drain spud and drain hole with plumber's putty (supplied by installer).*

1. Secure drain spud with lock nut and washers as shown in Figure 7.

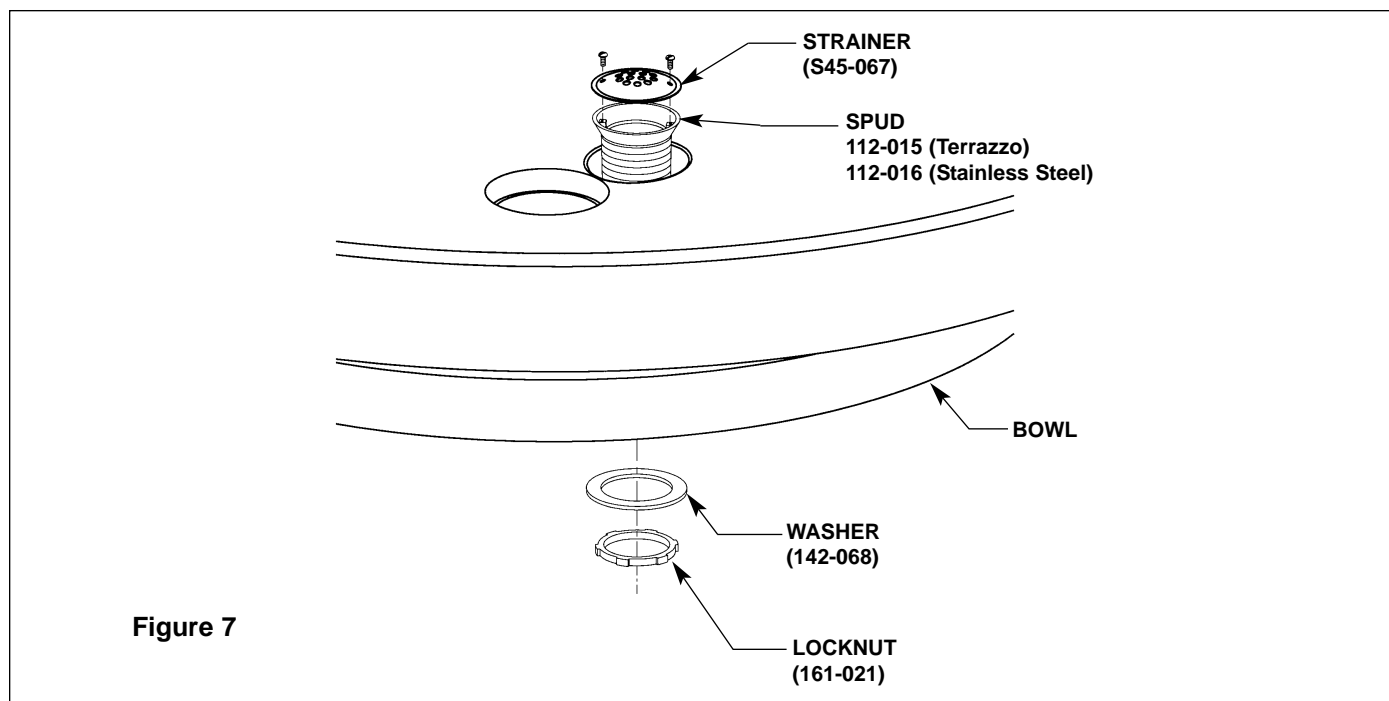

Figure 7

## Installation Instructions *continued* . . .

### **Step 5a: Installing Supplies with Optional Soap Dispenser for A/O drain units**

*NOTE: See Step 5b for units with type B/H drain.*

*NOTE: For models with optional paper towel dispensers, tie pipe assembly, or shroud, see separate instruction sheets and Step 5b for units with type B/H drain.*

*NOTE: Flush the supply lines before making connections.*

1. Install the hemmed end (not sharp end) of the support tube with the gasket into the bowl.
2. Using pipe sealant, connect the supply pipe to the sprayhead and place on top of the support tube as shown in Figure 8 on page 12.

#### **3a. For Unit with Soap Option:**

1. Place the upper tie bar on top of the sprayhead and join the upper and lower tie rod (the longer threaded rod) with the coupling nut and setscrews.
2. Insert the tie rod assembly through the hole in the upper tie bar and secure with the lower tie bar, tie rod nut and setscrew from below (see Figure 8).
3. Install the spacer, soap dispenser, dispenser cover and secure with the acorn nut and socket setscrew.
4. Continue installation with Step 7 on Page 16.

#### **3b. For Unit without Soap Option:**

1. Place the dispenser cover on the sprayhead. Thread the acorn nut onto the lower tie rod, run the tie rod through the dispenser cover and secure from below with the lower tie bar, tie rod nut and socket setscrew (see Figure 8).
2. Continue installation with Step 6 on Page 15.

**TYPE "O" DRAIN**  
 (Supplies from above)

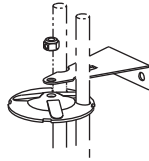

**TYPE "A" DRAIN**

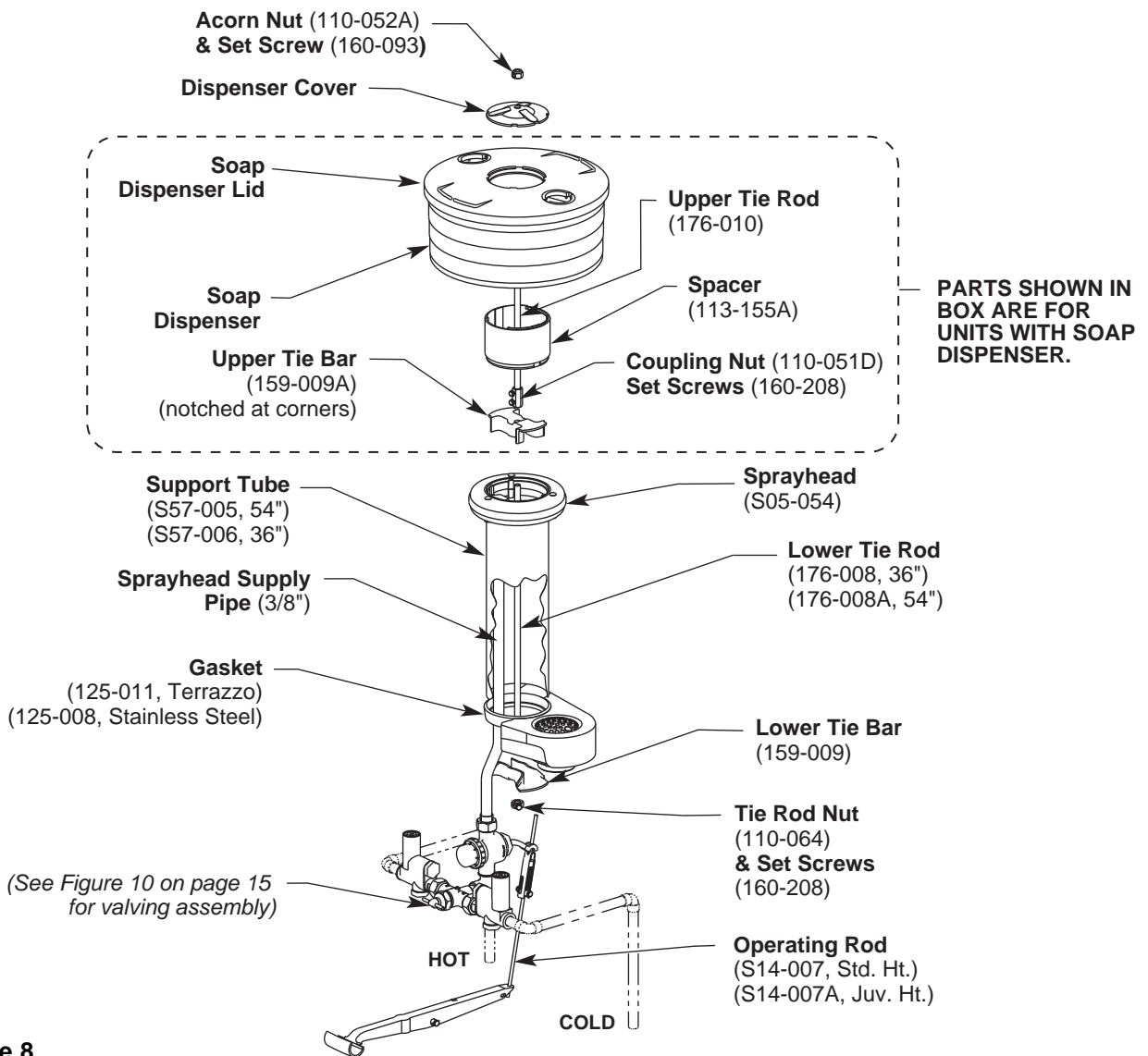

Figure 8

## Installation Instructions *continued* . . .

### Step 5b: Installing Supplies with Optional Soap Dispenser for B/H drain units

*NOTE: Flush supply lines before making connections.*

1. Install the hemmed end (not sharp end) of the support tube with gasket onto the bowl.
2. Using pipe sealant, connect the supply pipe to the sprayhead and place on top of the support tube as shown in Figure 9 on page 14.
3. Insert the 1-1/2" vent pipe (supplied by installer, see page 4 for length) through the soap dispenser with the spacer (if provided), sprayhead and support tube.
4. Connect to the vented trap (provided).

#### 5a. For Unit with Soap Option:

1. Slide the tie bar over the 1-1/2" vent pipe 1/2" below the top of the soap dispenser and secure with the set screws.
2. Slide the dispenser cover over the 1-1/2" vent pipe and secure with the two screws (included) to the tie bar.

#### 5b. For Unit without Soap Option:

1. Slide the tie bar over the 1-1/2" vent pipe, 1/2" below the top of the sprayhead and secure with the set screws.
2. Secure the dispenser cover over the 1-1/2" vent pipe and secure with the two screws included with the tie bar.

### 6. Connect the Vent Pipe

- a. Connect the vent pipe to the vent through the ceiling with the pipe union.
- b. Continue installation with Step 6 on Page 15.

Installation Instructions *continued . . .*

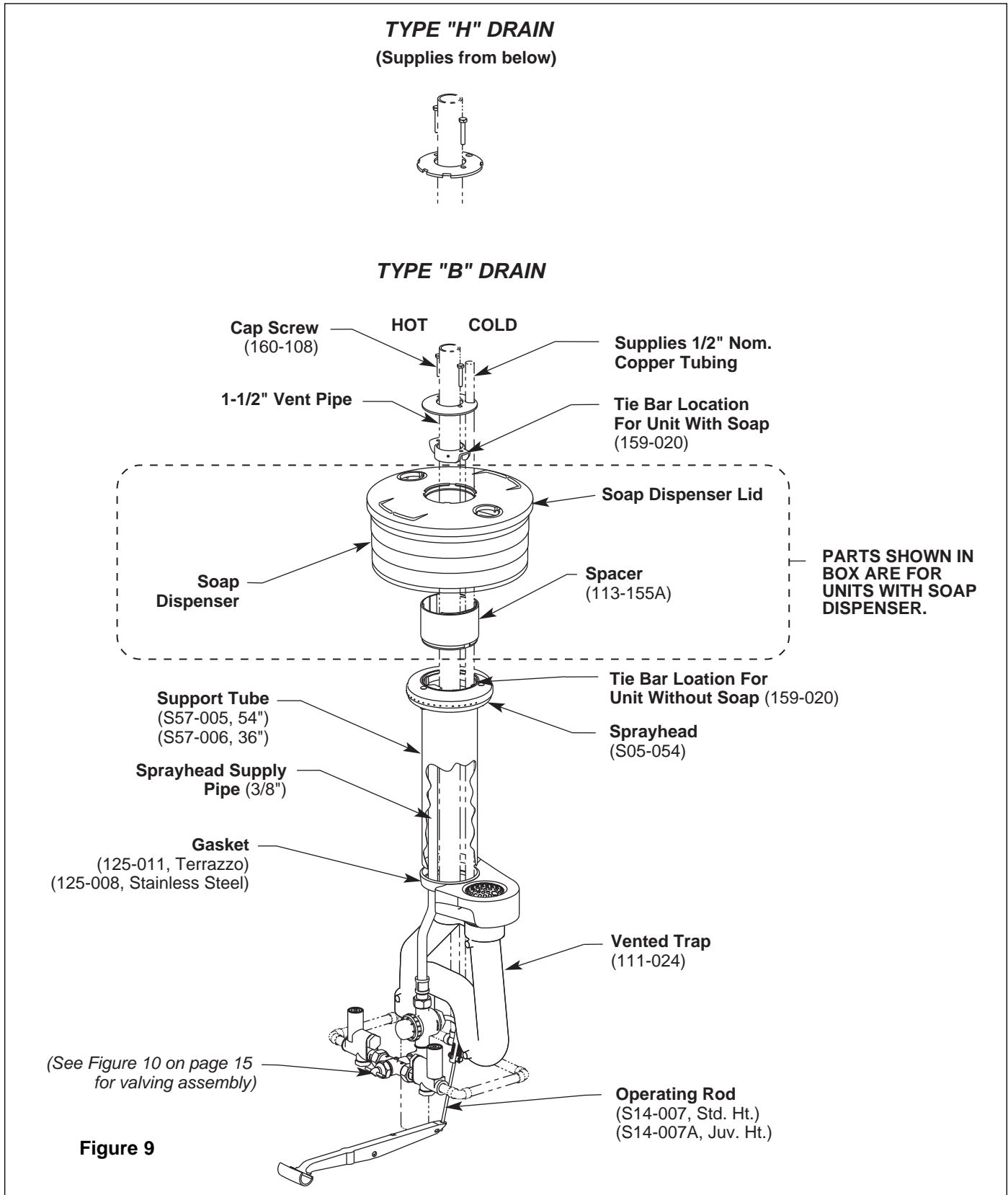

## Installation Instructions *continued* . . .

### Step 6: Installing the Valve Assembly

*NOTE: Flush supply lines before making connections.*

1. Connect the stop-strainer-check valves, mixing valve, volume control valve, and foot valve as shown in Figure 10.
2. For overhead supply lines, install 1/2" nominal copper supply tubing by passing the lines through the holes in the dispenser cover and then down through the support tube.
3. Install the valving assembly using suitable fittings to the supplies as shown in Figure 10 at the approximate height indicated in Table 2.
4. Slide the tailpiece nut over the tailpiece and connect the tailpiece to the supply pipe (or to the nipple/coupling for B or H drain).

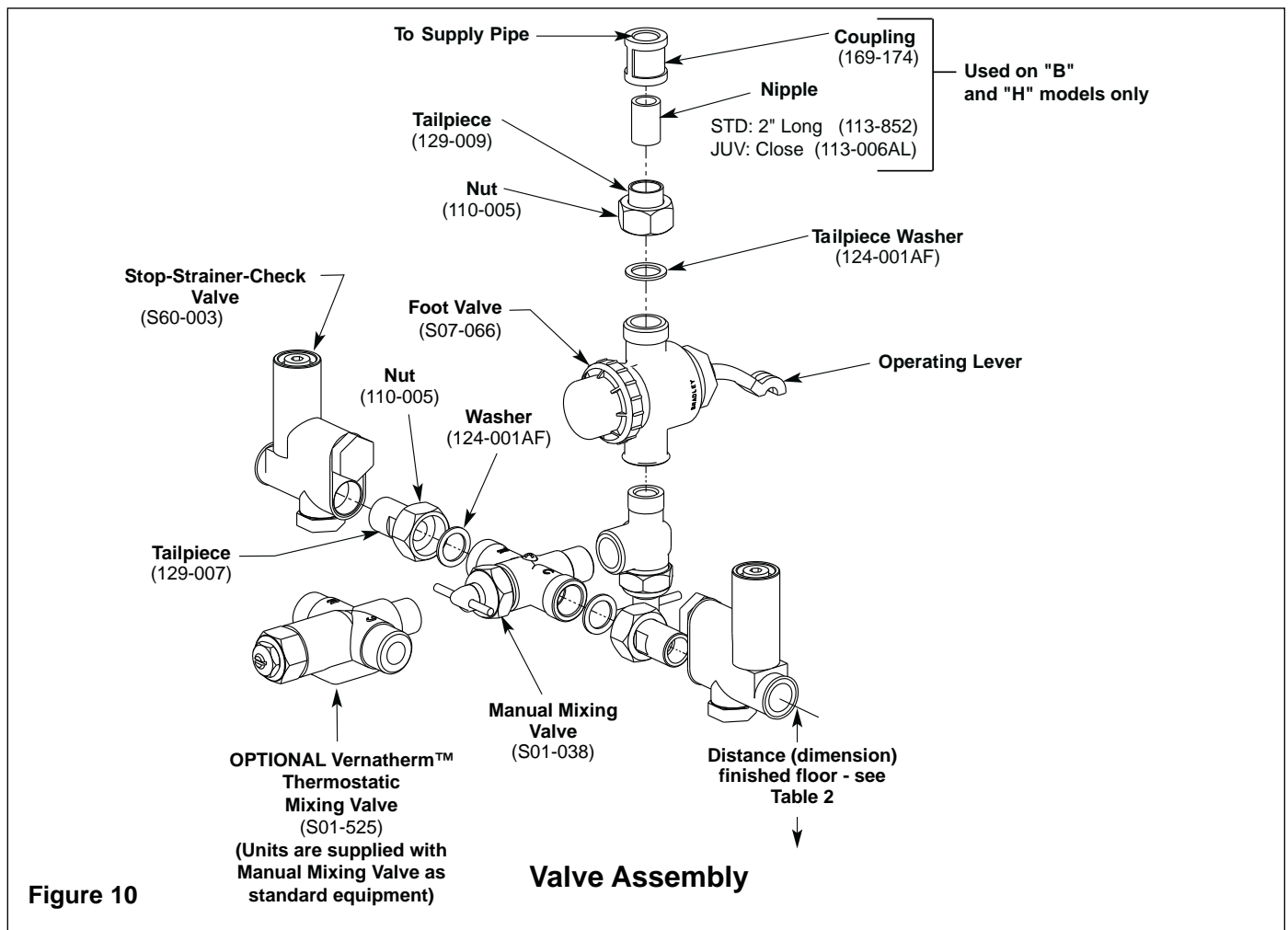

**Table 2 — Distance to Finished Floor**

Model Number	Type A	Type B	Type H	Type O
Standard Height	9" (229mm)	6-3/16" (157mm)	6-3/16" (157mm)	9" (229mm)
Juvenile Height	5-1/4" (133mm)	3-7/16" (87mm)	3-7/16" (87mm)	5-1/4" (133mm)

## Installation Instructions *continued* . . .

### Step 7: Installing the Operating Rod

1. Insert the operating rod in the operating rod lever and then into the foot lever (see Figure 11).

*NOTE: For normal operation, use the operating rod as shipped. The spring loaded cartridge should be adjusted so there is no play in the operating lever. Care must be taken to insure that a snug fit is achieved without activating the foot valve or water will leak from the sprayhead (see Figure 11).*

2. When movement of the operating rod is insufficient to open the foot valve, disassemble the rod and remove the spacer and override spring. Reassemble the operating rod as shown in Figure 12. Reinstall and adjust so that the foot valve is completely open when the foot lever is fully depressed. This prevents damage to the foot valve due to the absence of the override spring.
3. Turn supplies on and activate the sprayhead. Check piping installation for leaks.
4. Clean the sprayhead if necessary. See page 22 for sprayhead troubleshooting. Adjust the volume control valve, if necessary, to control the flow of water.

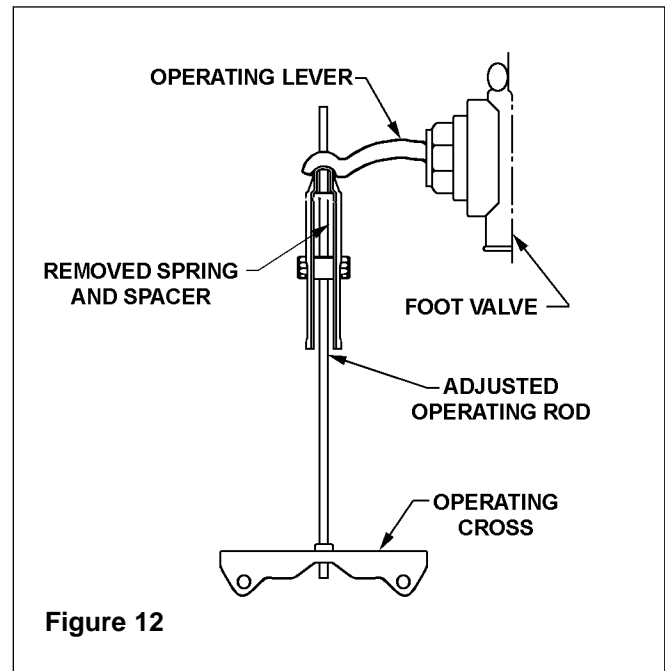
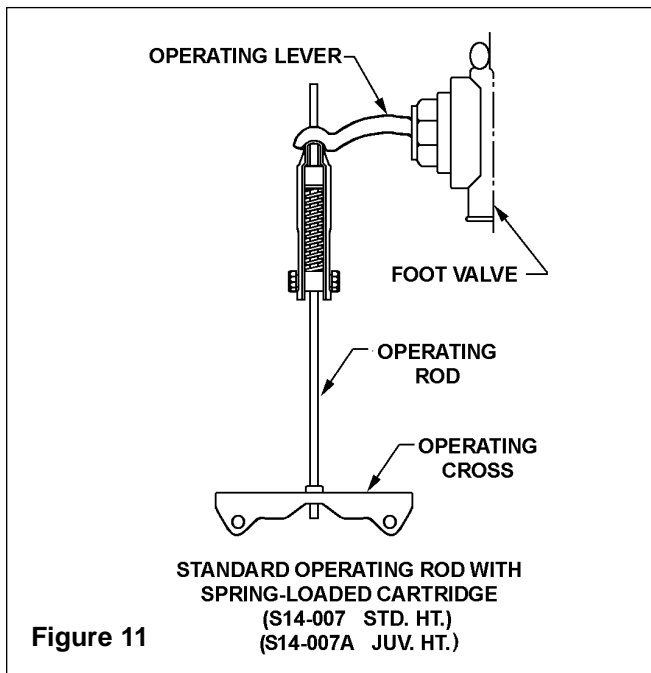



## Soap Recommendations and Maintenance Tips

Quality soap dispensers require good quality soap and periodic maintenance to properly operate. Bradley soap dispensers will provide dependable, consistent operation over the long term when soap with reasonable viscosity and pH levels are used and when a minimal amount of periodic maintenance is performed on the valves.

Soap thickness is determined by a measurement called viscosity. Soap viscosity should be between 100 cps (centerpoise) and 2500 cps for all Bradley soap dispensers. Thinner soaps are perceived by the users as being “watered down” so users tend to take more than they need, resulting in waste. *Thick soaps flow slower and inhibit the “flushing” action of the valves, which allows the soap to congeal in the valve and cause clogs.*

The pH (acid) level of the soap should be in the range of 6.5 to 8.5. More acidic soaps (pH levels lower than 6.5) will corrode metal parts (even stainless steel!!) and degrade rubber and plastic components. They will also cause skin irritation. *Most inexpensive soaps (typically the pink lotion type) fall into this acidic category and will eventually cause valve failure and metal corrosion.* Base soaps (pH levels higher than 8.5) will cause swelling or degradation of rubber and plastic parts and skin irritation.

Generally, any quality soap meeting the viscosity and pH guidelines above will work well with Bradley soap dispensers. PCMX or Isopropanol based antibacterial soaps (within viscosity and pH limits) will also work with Bradley dispensers. Soaps satisfying these basic guidelines will provide consistent flow and reduce clogs.

Most soap dispenser problems are caused by soap that is too thick or corrosive, or by a lack of maintenance. Many soaps come in concentrate form which must be diluted with water. Often, the soap is improperly diluted or used straight out of the bottle, which causes clogging and valve failure. If proper soap is being used, valves that have never been cleaned are usually the source of dispensing problems. Bradley has entered into an agreement with Champion Brand Products to provide additional customer service for purchasers of our dispensers regarding soap issues. They are very helpful and can get to the bottom of almost any soap dispenser-related problem. They also sell an excellent “Bradley approved” soap. Please see Bradley Instruction sheet 215-1286 for soap valve cleaning details and Champion Brand Products contact information.

## Check Valve Troubleshooting

### If water just dribbles or does not flow from sprayhead:

1. Turn off water supplies to fixture.
2. Inspect check valves for proper installation. See Stop, Strainer and Check Valve on page 19.
3. Open the stops and clean the strainers, if necessary.

### If water sprayhead delivers all hot or cold water:

1. Turn off water supplies to fixture.
2. Inspect check valves for proper installation.
3. Open the stops and clean the strainers, if necessary.
4. Inspect mixing valve for proper installation (see Vernatherm valve on page 24).

## Soap Valve - Liquid - S09-007S

This valve delivers a measured amount of soap with each upward stroke. The soap dispenser has been standard on washfountains since 1983 and is not well-suited for very thick lotion soaps.

*NOTE: Lotion soap will clog liquid soap valves. Use only lotion soap valves with lotion soap.*

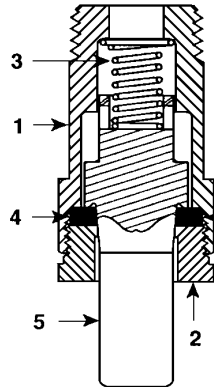

### Parts List

\* Not Illustrated

Item	Part No.	Description	Attaching Parts S09-007S	
			Qty	
1	118-025	Valve Body	1	
2	110-007	Packing Nut	1	
3	135-001L	Spring	1	
4	125-001BU	Washer	1	
5	119-028	Plunger	1	
*	161-014	Nut	1	
*	124-001D	Washer	2	
*	142-002AH	Washer - Stainless Steel	1	

## Soap Valve - Lotion - S09-057S Parts List

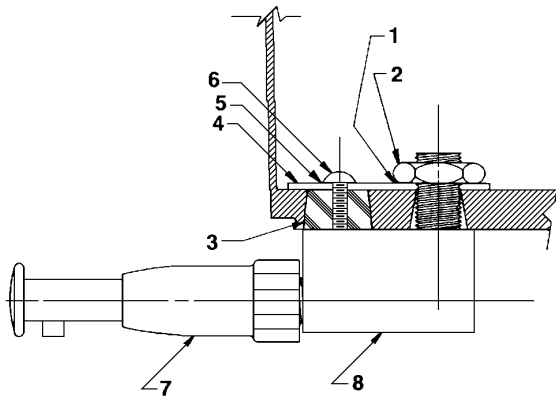

Item	Part No.	Description	Valve Assembly S09-057	Attaching Parts S09-057S
			Qty	
1	124-001D	Washer	—	1
2	110-057	Nut	—	1
3	125-001AN	Stopper	—	1
4	159-114	Reinforcing Plate	—	1
5	124-001AT	Washer	—	1
6	160-176	Screw	—	1
7	S09-040	Valve	1	1
8	S53-045	Adaptor	1	1

## Soap Valve - Powdered - S09-010A

### Parts List

Item	Part No.	Qty	Description
1	160-069	1	Screw, 1/4-20 RD
2	142-002X	1	Washer, 1/4 Split-Lock
3	S62-002	1	Agitator / Slide Assy.
4	192-004	1	Lever - Powdered Soap

*NOTE: Reducer plugs are available for use with fine granulated soap to reduce the flow.*

*NOTE: Valves can be changed from powdered to liquid by plugging the innermost, or "bearing" hole with rubber plug, part number 125-001AK. To change from liquid to powdered, the plug must be removed. If none is present, it will be necessary to drill out the bearing hole with a 1/2" or 5/8" drill. The plastic container configuration forms a natural template for locating the bearing hole.*

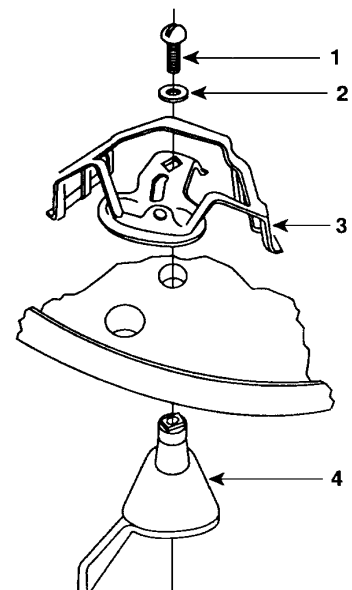

## Stop, Strainer and Check Valve

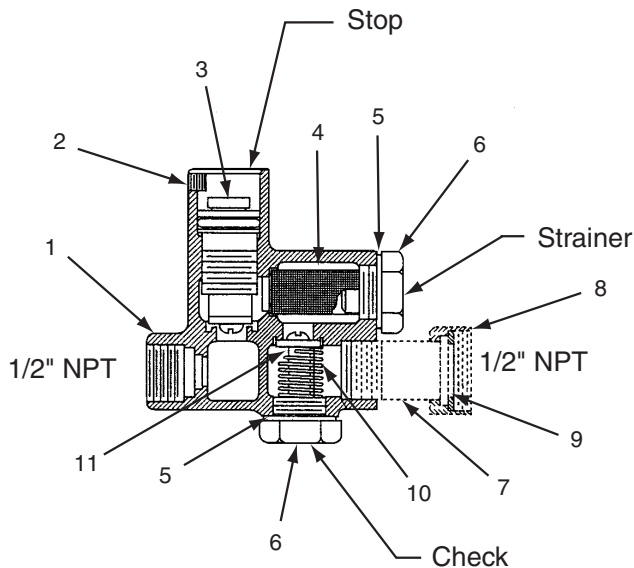

### Parts List Stop Assembly S21-014 Standard Celcon Core

Item	Part No.	Qty	Description
1	119-057	1	Valve Core
*2	125-001AW	1	"O" Ring
*3	125-001L	1	Bibb Washer
4	160-164	1	Screw

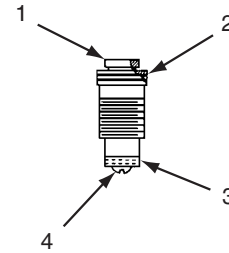

### Parts List S60-003 Stop, Strainer and Check Valve

Item	Part No.	Qty	Description
1	118-039	1	Valve Body - Brass
1	118-039A	1	Valve Body - Plated
2	160-131	1	Set Screw
3	S21-014	1	Stop Assembly - Celcon
3	S21-026	1	Stop Assembly - Brass
*4	156-006	1	Strainer
*5	124-001BV	2	Fiber Washer
*6	153-068	2	Plug - Brass
7	129-007	1	Tail Piece - Brass
7	129-007A	1	Tail Piece - Plated
8	110-005	1	Tail Piece Nut - Brass
8	110-005A	1	Tail Piece Nut - Plated
*9	124-001AF	1	Tail Piece Washer
*10	135-001AB	1	Spring
*11	S21-015	1	Check Assembly

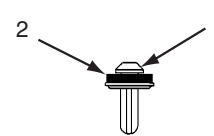

### Parts List Check Assembly S21-015\*

Item	Part No.	Qty	Description
1	119-091	1	Plunger
2	125-001BB	1	Washer

\* S45-050 Repair Kit Includes these parts

## Sprayhead Troubleshooting and Repair Parts

### Problem: Water splashes over the rim of the bowl.

*Cause: Foreign matter has reduced the size of the sprayhead slots, causing greater pressure at the open slots.*

Solution: Clean the sprayhead:

1. Disassemble the sprayhead and dislodge any dirt, lime build-up and foreign debris with a wire brush.
2. Sprayheads with rubber grommet spray rings may be cleaned by rubbing a coin over the grommet.
3. Throttle down the volume control (water spray should strike the bowl without splashing outside of the bowl).

### Problem: Water flow diminishes from the sprayhead.

*Cause: Strainer portion of the stop-strainer-check valve is plugged.*

Solution: Remove and clean the strainer screen from the stop-strainer-check valve.

*NOTE: The sprayhead shown below includes a perforated rubber spray ring grommet that is self-cleaning. The water pressure flexes the spray holes which slows accumulation of foreign matter and tends to "break loose" any such deposits that may have accumulated.*

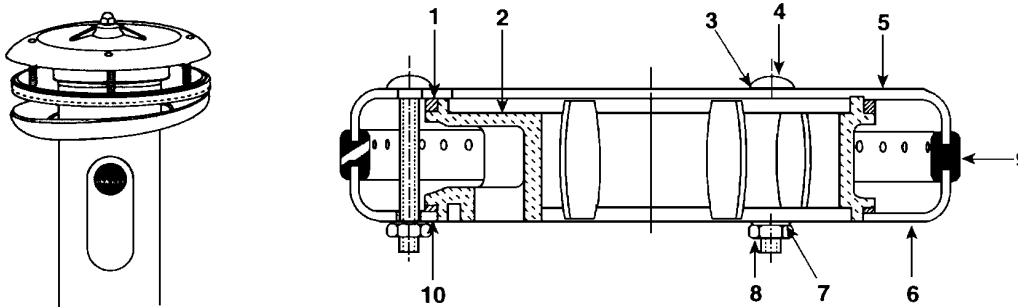

## Parts List

Item	Part No.	Description	Sprayhead Assembly S05-054	Repair Kit S45-051
			Qty	
1	125-001DE	Neoprene Washer-Top	1	1
2	139-031	Sprayhead Manifold	1	—
3	124-001AL	Washer	3	4
4	160-211	Carriage Bolt	3	4
5	115-061	Sprayhead Top	1	—
6	116-008	Sprayhead Bottom	1	—
7	124-001AT	Washer	3	4
8	161-025	Nut	3	4
9	124-020C	Sprayhead Grommet - Circle	1	—
10	125-001DF	Neoprene Washer-Bottom	1	1

Repair Parts *continued* . . .

**S65-230 — Repair Kit for Foot Valve S07-066**

**S07-066 Foot Valve**

ITEM	QTY.	PART NO.	DESCRIPTION
1	1	118-302	FOOT VALVE BODY
2	1	125-154	O-RING, #2-127
3	1	118-300	HOUSING
4	1	135-088	SPRING
5	1	117-016	VALVE SEAT
6	1	S64-093	PLUNGER ASSEMBLY
7	1	125-001Y	DIAPHRAGM
8	1	179-002	PLUNGER GUIDE
9	1	119-024	PLUNGER
10	1	143-026	OPERATING LEVER
11	1	110-101	BOTTOM NUT
12	1	124-001V	WASHER, 1-3/8" x 5/8"

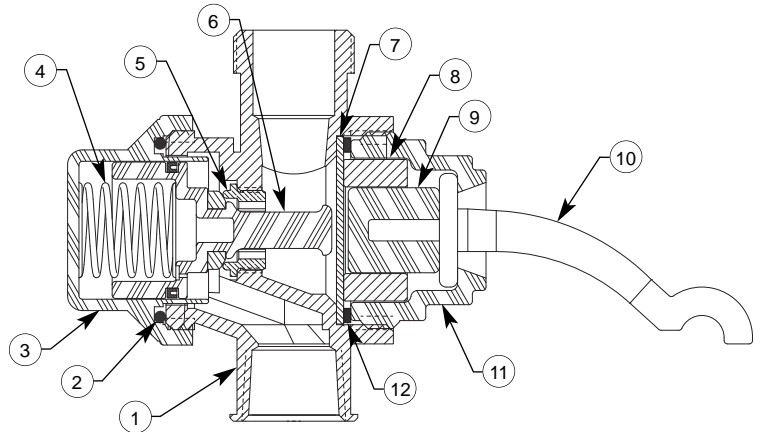

**NOTE:** This repair kit services only the S07-066 valve shipped AFTER January 2003.  
 See 215-1370 *Washfountain Parts and Service Guide* for service information before this date.

**S65-230 Foot Valve Repair Kit**

ITEM	QTY.	PART NO.	DESCRIPTION
1	1	118-300	HOUSING
2	1	135-088	SPRING
3	1	125-154	O-RING, #2-127
4	1	S64-093	PLUNGER ASSEMBLY
5	1	117-016	VALVE SEAT
6	1	125-001Y	DIAPHRAGM
7	1	124-001V	WASHER, 1-3/8" x 5/8"
8	1	130-033	KEY, VALVE SEAT
9	1	S45-125	LUBRICANT (not shown)

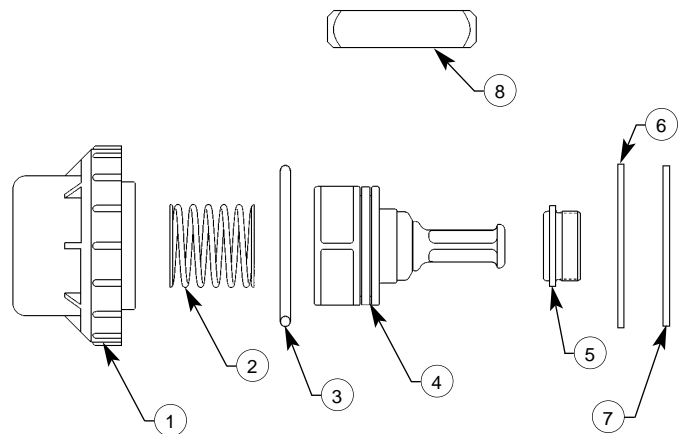

## Manual Mixing Valve Repair Parts

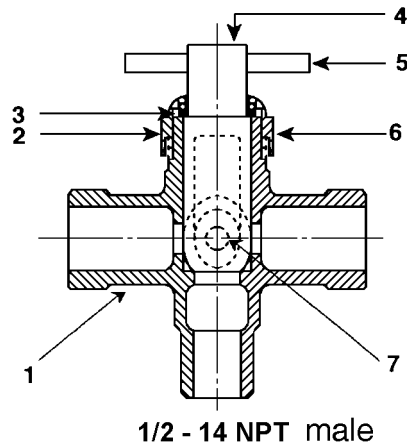

## Manual Mixing Valve Parts List

Item	Part No.	Description	Valve Assembly S01-038	Valve and Tailpieces S01-038S	Repair Kit S45-197
			Qty		
1	118-034	Mixing Valve Body - Brass	1	1	—
1	118-034A	Mixing Valve Body - Chrome	—	—	—
2	124-001BD	Fiber Washer	1	1	1
3	125-001BC	O-Ring	1	1	1
4	119-059	Mixing Valve Core	1	1	1
5	152-038	Roll Pin	1	1	1
6	121-016	Bonnet - Brass	1	1	1
6	121-016A	Bonnet - Chrome	—	—	—
7	160-197	Screw - Brass	1	1	—
7	160-189	Screw - Stainless Steel	—	—	—
*	129-007	Tailpiece - Brass	—	2	—
*	110-005	Tailpiece Nut - Brass	—	2	—
*	129-007A	Tailpiece - Chrome	—	—	—
*	110-005A	Tailpiece Nut - Chrome	—	—	—
*	124-001AF	Tailpiece Washer	—	2	2

\* Parts not shown

## Volume Control Valve Repair Parts

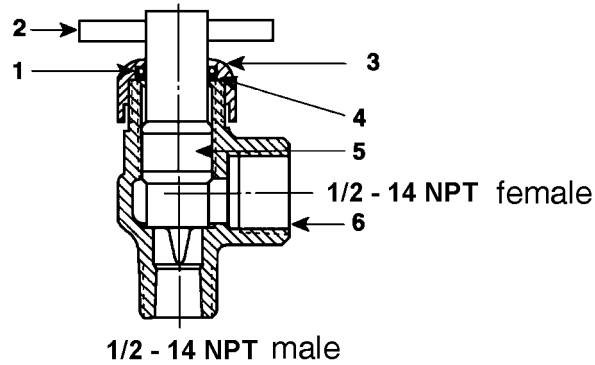

## Volume Control Valve Parts List

Item	Part No.	Description	Brass Valve S02-045	Repair Kit S45-198
			Qty	
1	125-001BC	O-Ring	1	1
2	152-038	Roll Pin	1	1
3	121-016	Bonnet	1	1
3	121-016A	Bonnet	—	—
4	124-001BD	Fiber Washer	1	1
5	119-060	Valve Core	1	1
6	118-033	Valve Body	1	—
6	118-033B	Valve Body	—	—

## Adjusting the Vernatherm Thermostatic Mixing Valve

**⚠** *NOTE: This valve is **NOT** factory preset. Upon installation, the temperature of this valve must be checked and adjusted to ensure delivery of a safe water temperature. **Water in excess of 110°F (43°C) may cause scalding.***

1. Check the temperature when approximately 1.0 GPM water flow is reached and adjust if necessary (the range of the valve is 95°F–115°F (35°C–43°C). To adjust the temperature, follow the procedure below:
  - Loosen temperature locking nut with wrench.
  - Using a blade screwdriver, turn the adjustment stem **counterclockwise** to **increase** the temperature or **clockwise** to **decrease** the temperature (Figure 13).
  - Once desired temperature has been reached, tighten lock nut to prevent change in temperature.
2. Shut the hot water inlet off by closing the hot water stop-strainer-check valve. While the hot water supply is turned off, check to make sure the cold water flow is reduced. If the cold water is reduced properly, reopen the hot water supply.
3. Shut the cold water inlet off by closing the cold water stop-strainer-check valve. While the cold water supply is off, check to make sure that the hot water flow has shut down.

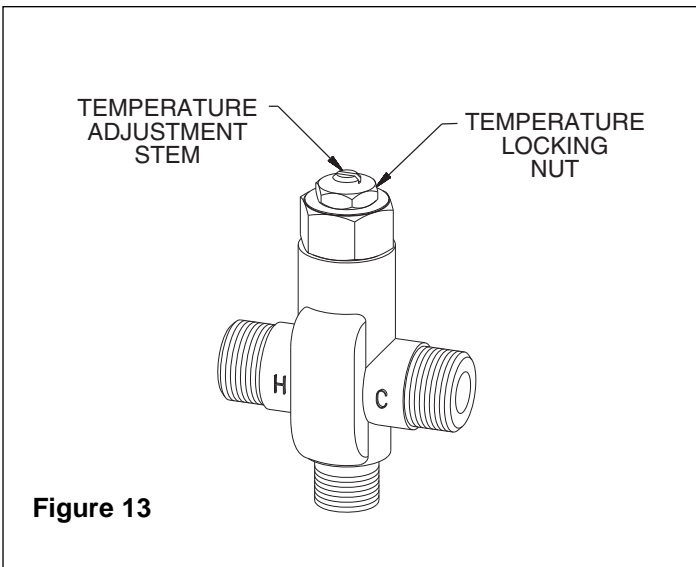



## Thermostatic Mixing Valve Maintenance and Troubleshooting



**NOTE:** Before attempting to troubleshoot the valve or disassemble the components, check for the following conditions:

- If stop/check valves are used, make sure that they are fully open
- Make sure that the hot and cold inlet pipes are connected properly, and that there are no cross-connections or leaking stop/check valves
- check the hot water heater output to make sure that it is at least 20° F above the set temperature.

Be sure to close the appropriate shut-off valves prior to disassembly of the valve and reopen the valves after inspection and repair is complete.

### Problem: Limited water flow

*Cause:* Dirt and debris have built up in the valve.

**Solution:** Check the valve's piston for free and smooth movement, follow the procedures outlined below:

1. Remove the valve's cap and thermostat (see Figure 14 on Page 26).
2. Push down on the piston with your finger (the piston should move freely). If the movement is not as it should be, the piston needs to be cleaned. Follow the method outlined below for cleaning the piston and valve body:
  - Remove the thermostat.
  - Lift the piston out with a needle-nose pliers and remove the spring.
  - Any cleaner suitable for brass and stainless steel may be used (if cleaning with suitable cleaner is not sufficient to remove debris, a 400-grit sandpaper may be used to polish and hone the piston and valve body).
  - Snap spring into piston (will detent) and reassemble into the valve body.
  - Retest the piston.
3. If, after a thorough cleaning, the piston does not move freely, the piston must be replaced. Contact your Bradley representative and ask for Repair Kit (part number S65-259).

### Problem: External leaks in the system

*Cause:* O-rings have been damaged.

**Solution:** Replace O-rings where necessary. For replacement of the O-rings, contact your Bradley representative and ask for Repair Kit (part number S65-259).

### Problem: Improper water temperature or temperature fluctuation

*Cause:* Thermostat is slowly failing or not working at all.

**Solution:** "Check the thermostat for proper operation".

1. At room temperature (80° F or less) remove cap and thermostat.
2. Place thermostat into container with 115° F water. The pushrod should pop out of the thermostat approximately 1/10".
3. If thermostat pushrod does not pop out, the thermostat must be replaced. Contact your Bradley representative and ask for Repair Kit (part number S65-259).

*Cause:* Valve temperature is not properly set.

**Solution:** "Adjust the temperature" per steps on Page 24.

## Vernatherm Thermostatic Mixing Valve (S01-525) Parts List — Repair Kit S65-259

### Parts List S65-259 Valve Repair Kit

Item	Part No.	Qty	Description
5	S39-413	1	Thermostat
7	125-001BX	1	O-Ring
8	125-157	1	O-Ring

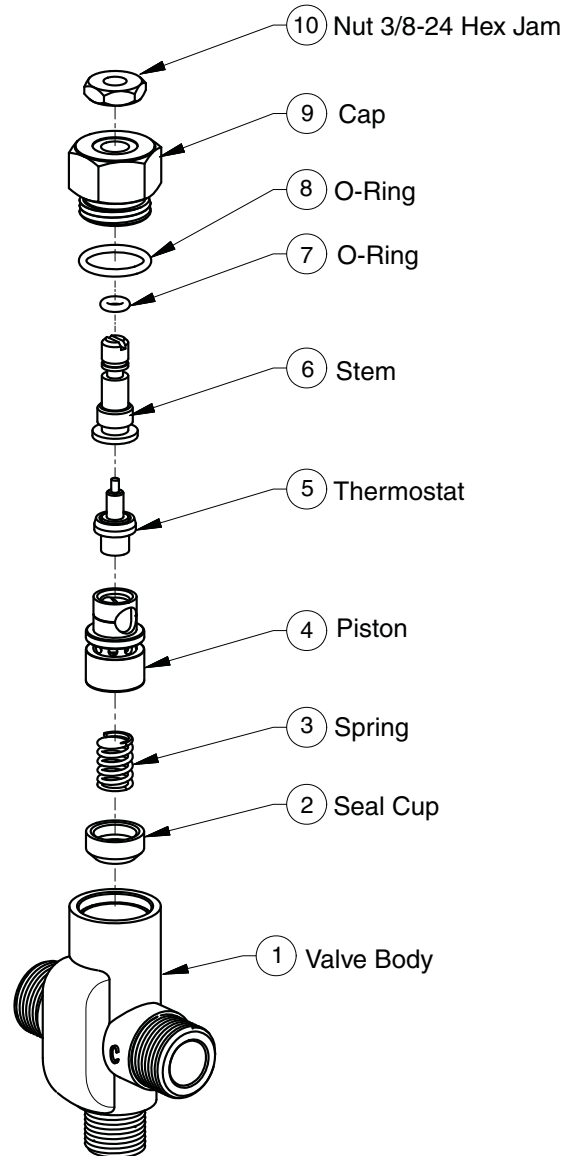

Figure 14

## Cleaning of Washfountains

### To Preserve Finish of Terrazzo Compositions

Clean terrazzo Washfountain bowls daily or as often as conditions require with any standard household detergent, hot water and soft cloth. Bradley terrazzo bowls may be refurbished by cleaning with tri-sodium phosphate, two pounds per gallon, and a scrub brush. Stubborn spots may be removed with emery cloth. After bowl is thoroughly cleaned and dried, Epoxy resin or a good quality polyurethane finish should be applied.

Eroded terrazzo is usually the result of exposure to caustic substances. This condition can be repaired relatively easily. Repair kits are available from your Bradley Representative. Do not use drain cleaners on terrazzo.

### Drain Cleaning

Drains can be cleaned with a plumbers snake inserted through the drain spud after removing the strainer, or through the trap clean out plug



**IMPORTANT: Do not put drain cleaners in bowl. Damage to bowl will result.**

## Cleaning and Maintenance Instructions for Stainless Steel

**Material Description:** Stainless steel is extremely durable, and maintenance is simple and inexpensive. Proper care, particularly under corrosive conditions, is essential. Always start with the simplest solution and work your way toward the more complicated.

**Routine cleaning:** Daily or as often as needed use a solution of warm water and soap, detergent, or ammonia. Apply the cleaning solution per the manufactures instructions and always use a soft cloth or sponge to avoid damaging the finish.

**Stubborn Stains:** To remove stains from stainless steel use a stainless steel cleaner and polish such as Ball® stainless steel cleaner or a soft abrasive. Always follow the manufactures instructions and apply in the same direction as the polish lines.

 **IMPORTANT: NEVER USE ORDINARY STEEL WOOL OR STEEL BRUSHES ON STAINLESS STEEL. ALWAYS USE STAINLESS STEEL WOOL OR STAINLESS STEEL BRUSHES.**

### Special Situations for Material

**Fingerprints and Smears:** To remove fingerprints or smears use a high quality stainless steel cleaner and polish in accordance with the manufactures instructions. Many of these products leave a protective coating the helps prevent future smears and fingerprints.

**Grease and Oil :** To remove grease and oil use a quality commercial detergent or caustic cleaner. Apply in accordance to the manufactures instructions and in the direction of the polish lines.

**Precautions:** Avoid prolonged contact with chlorides (bleaches, salts), bromides (sanitizing agents), thiocyanates (pesticides, photography chemicals, and some foods), and iodides on stainless steel equipment, especially if acid conditions exist.

 **IMPORTANT: DO NOT PERMIT SALTY SOLUTIONS TO EVAPORATE AND DRY ON STAINLESS STEEL.**

The appearance of rust streaks on stainless steel leads to the belief that the stainless steel is rusting. Look for the actual source of the rust in some iron or steel particles which may be touching, but not actually a part of the stainless steel structure.

*NOTE: Strongly acidic or caustic cleaners may attack the steel causing a reddish film to appear. The use of these cleaners should be avoided.*

**Brand Names:** Use of brand names is intended only to indicate a type of cleaner. This does not constitute an endorsement, nor does the omission of any brand name cleaner imply its inadequacy. Many products named are regional in distribution, and can be found in local supermarkets, department and hardware stores, or through your cleaning service. It is emphasized that all products should be used in strict accordance with package instructions.