

WF2603

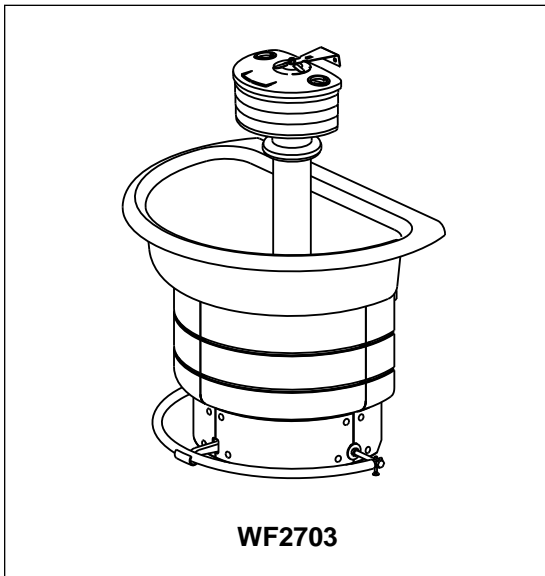

WF2703



**IMPORTANT**

**Read this entire installation manual to ensure proper installation.**

**Flush all the water supply lines before making connections.**

**Main water supply to the unit should be ON at all times.**

**This installation manual and parts list should be filed by the owner or maintenance department.**

# Installation Instructions

**WF2603, WF2604 Terrazzo  
WF2703, WF2704 Stainless Steel**

## Classic Semi-Circular 36"/54" Washfountain with Air Valve Control

### Table of Contents

Pre-Installation Information .....	2
Warranty .....	2
Semi-Circular Washfountain Dimensions .....	3-4
Rough-In Specifications .....	5-8
Drain Rough-In Specifications .....	9
Assembling the Pedestal .....	10
Bowl and Pedestal Assembly and Mounting .....	11
Drain Spud Installation .....	12
Supplies with Optional Soap Dispenser (A/O drains) .....	13-14
Supplies with Optional Soap Dispenser (B/H drains) .....	15-16
Valve Connections For Air Valve .....	17
Adjust the Air Valve Metering Time .....	18
Air Valve Troubleshooting .....	19
Check Valve Troubleshooting .....	19
Air Valve Repair Kits and Parts List .....	20-21
Stop, Strainer, Check Valve Repair Parts .....	22
Soap Recommendations and Maintenance .....	23
Soap Dispensing Valve Repair Parts .....	24
Sprayhead Troubleshooting/Repair Parts .....	25
Manual Mixing Valve Repair Parts .....	26
Volume Control Valve Repair Parts .....	27
Vernatherm™ Mixing Valve Maintenance .....	28-30
Cleaning and Maintenance Instructions .....	31-32

UPC Certified



P.O. Box 309, Menomonee Falls, WI 53052-0309  
TEL. 1-800-BRADLEY FAX 262-251-5817  
<http://www.bradleycorp.com>

## Pre-Installation Information

### Air Valve

The sprayhead is controlled by a pushbutton that activates a single metered flow of water pre-blended to a specific temperature.

### Supplies required for installation:

- (6) 1/2" lag bolts, screws or other fasteners to anchor washfountain pedestal to floor
- 1" hot and cold water supply lines and fittings (refer to rough-ins on pages 5-8)
- Reducing fittings and 1/2" nom. copper tubing supply lines for types with supplies from above
- 2" drain lines and fittings (refer to rough-ins on pages 5-8)
- Standard P-trap (refer to rough-ins on page 9, special vented trap supplied for B and H type)
- Pipe sealant and plumber's putty
- 1-1/2" vent pipe on types vented through washfountain column (refer to page 4 for lengths required)

*NOTE: Supply lines for one or two washfountains should be 1"; for three washfountains 1-1/4"; for more than three washfountains pipe size should increase proportionally. Vent pipe to be 1-1/2" on models vented through washfountain.*

### Bradley Classic Washfountain Warranty Information

Product warranties may be found under "Product Information" on our website at [www.bradleycorp.com](http://www.bradleycorp.com)

## Semi-Circular Washfountain Dimensions

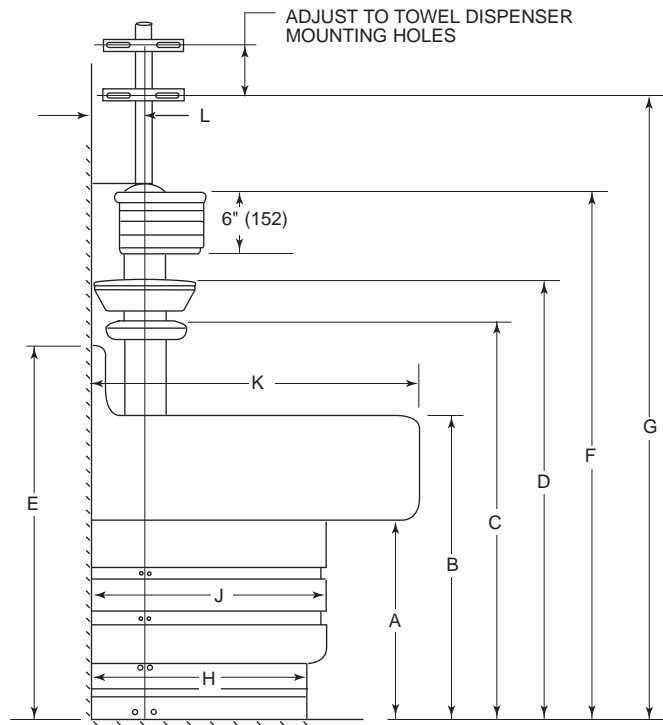

### Approximate Dimensions in Inches\*

Material	Size	A	B	C	D	E	F	G	H	J	K	L
Terrazzo	54"	19	29-1/4	39-1/8	42-5/8	36-1/4	51-1/8	59-1/2	21-1/4	23-1/2	32-1/4	5-1/4
Stainless	54"	19	28	37-3/8	40-7/8	32-1/4*	49-3/8	57-3/4	24-1/4	26-1/4	35-1/4	8-1/4
Terrazzo	36"	19	29-1/4	35-5/8	39-1/8	33-1/4	47-5/8	56	15-1/4	17-1/4	22-3/4	4-3/4
Stainless	36"	19	28	33-7/8	37-3/8	32-1/4*	45-7/8	54-1/4	18-1/4	20-1/4	25-3/4	7-3/4

\* Only when backplash is specified; otherwise, "B" applies. For juvenile height (Terrazzo only), subtract 4" from dimensions A–F.

### Approximate Dimensions in Millimeters\*

Material	Size	A	B	C	D	E	F	G	H	J	K	L
Terrazzo	1372	483	743	994	1083	921	1299	1511	546	591	819	133
Stainless	1372	483	711	949	1038	819*	1254	1467	616	667	895	210
Terrazzo	914	483	743	905	994	845	1210	1423	378	438	578	121
Stainless	914	483	711	860	949	819*	1165	1378	464	514	654	197

\* Only when backplash is specified; otherwise, "B" applies. For juvenile height (Terrazzo only), subtract 102mm from dimensions A–F.

## Length of Tie Pipe Required for Vent Through Washfountain Column

Type	Pipe Length
54" Less Soap Dispenser	21-1/2" (546mm)
36" Less Soap Dispenser	18" (457mm)
54" With Soap Dispenser	30" (762mm)
36" With Soap Dispenser	26-1/2" (673mm)
54" Less Soap Dispenser With Towel Dispenser	55-1/2" (1410mm)
36" Less Soap Dispenser With Towel Dispenser	52" (1321mm)
54" With Soap Dispenser With Towel Dispenser	48" (1219mm)
36" With Soap Dispenser With Towel Dispenser	44-1/2" (1130mm)
54" With Cube Adapter	32" (813mm)
36" With Cube Adapter	28-1/2" (724mm)
54" With Cube Adapter With Towel Dispenser	50" (1270mm)
36" With Cube Adapter With Towel Dispenser	46-1/2" (1181mm)
54" With Cube Adapter And Soap Dispenser	40" (1016mm)
36" With Cube Adapter And Soap Dispenser	36-1/2" (927mm)

*NOTE: Drain must be connected with 2" schedule 40 welded wrought iron pipe, minimum, to provide lower support for this installation. Vent or support pipe must be of the same material in 1-1/2".*

## Rough-In Specifications

### Type A

Off-Line Vent With Supplies From Below

### Top View

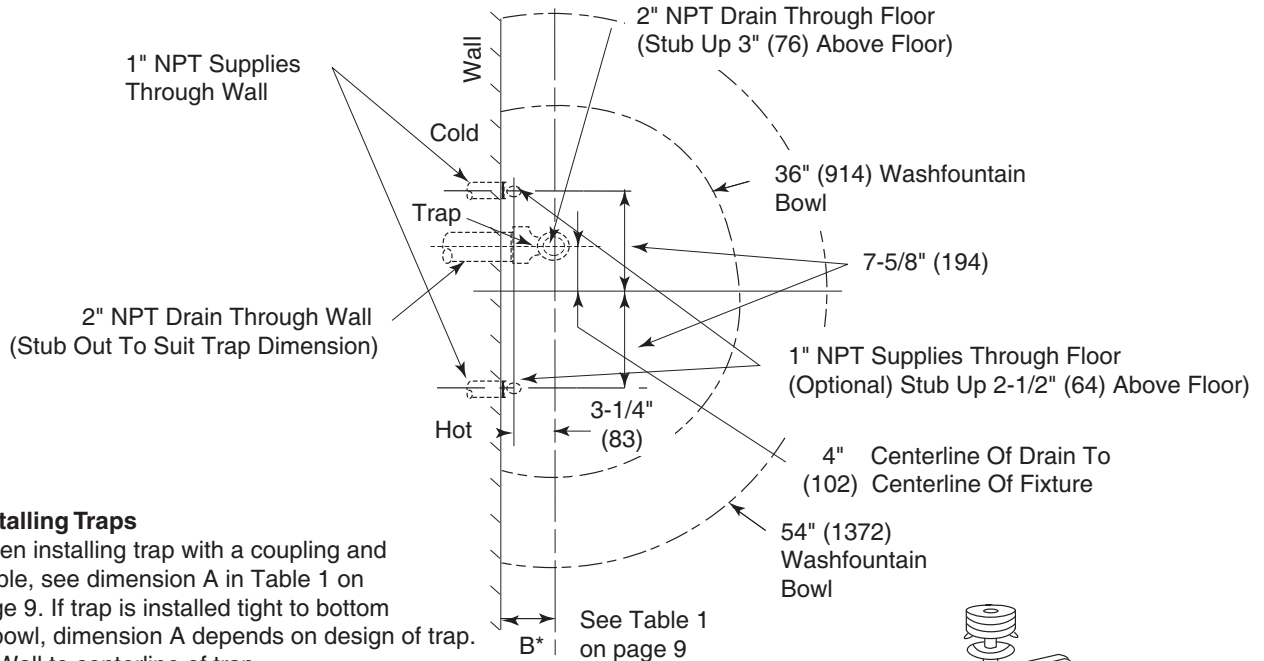

#### Installing Traps

When installing trap with a coupling and nipple, see dimension A in Table 1 on page 9. If trap is installed tight to bottom of bowl, dimension A depends on design of trap.  
B\* Wall to centerline of trap  
A\*\* Centerline of drain to floor

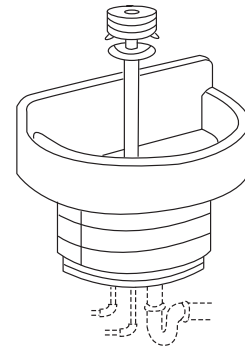

### Side View

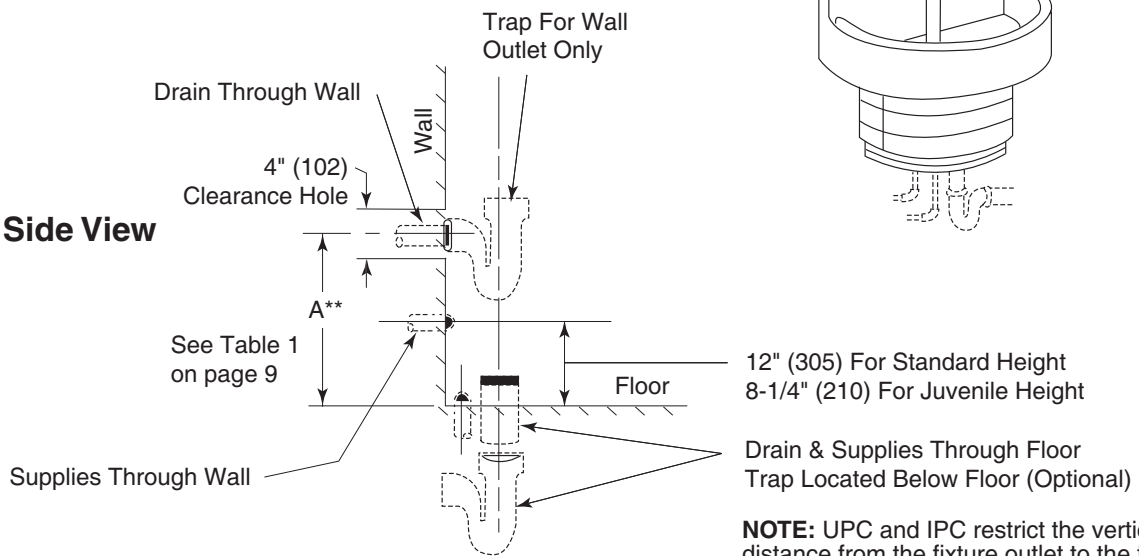

**NOTE:** UPC and IPC restrict the vertical distance from the fixture outlet to the trap weir to not more than 24". Check state and local codes for variances.

#### Rough-In Notes:

1. All pipes and fittings not furnished by Bradley are shown in broken lines.
2. Supply lines for one to two washfountains should be 1"; for three washfountains 1-1/4"; for more than three washfountains, pipe sizes should be increased proportionately.
3. Overhead supplies must be reduced to 1/2" copper tube to pass through support tube.
4. Check valve inlets are 1/2" NPT.
5. Dimensions shown in parentheses are millimeters.

## Rough-In Specifications *continued* . . .

### Type O

Off-Line Vent With Supplies From Above

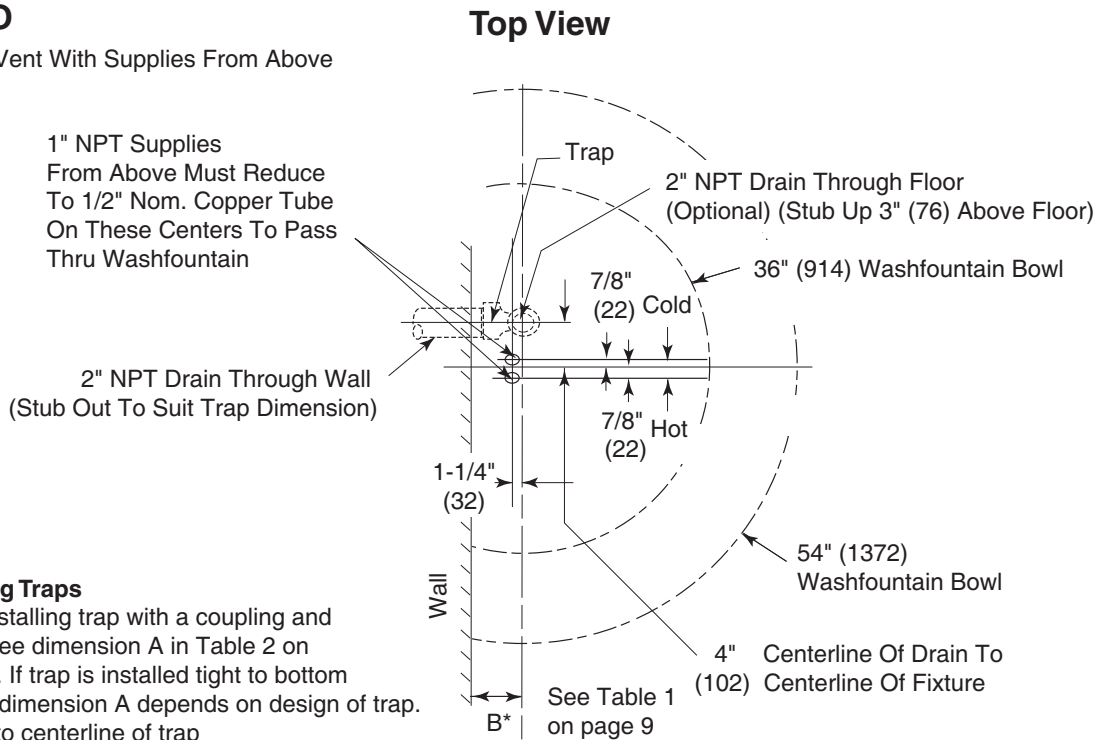

#### Installing Traps

When installing trap with a coupling and nipple, see dimension A in Table 2 on page 11. If trap is installed tight to bottom of bowl, dimension A depends on design of trap.  
 B\* Wall to centerline of trap  
 A\*\* Centerline of drain to floor

### Side View

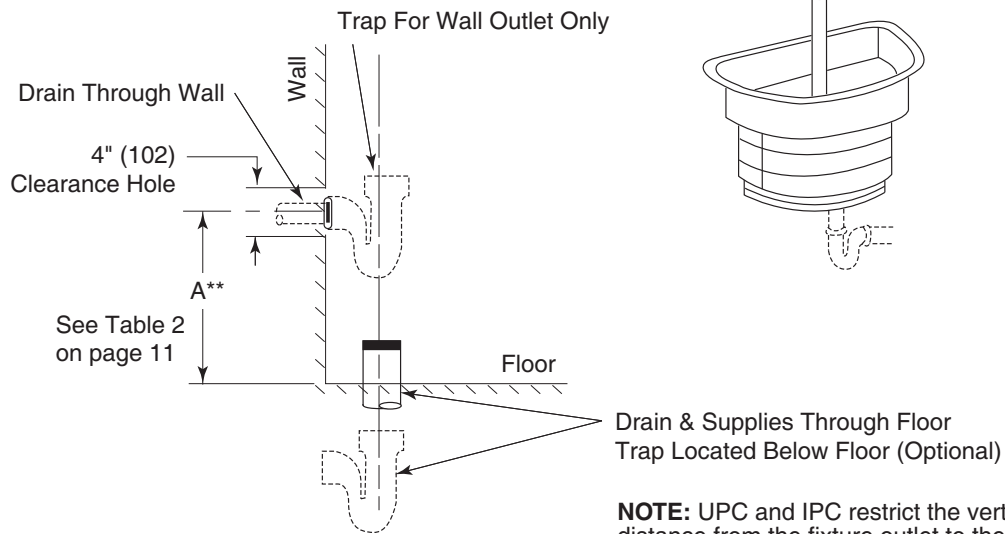

**NOTE:** UPC and IPC restrict the vertical distance from the fixture outlet to the trap weir to not more than 24". Check state and local codes for variances.

#### Rough-In Notes:

1. All pipes and fittings not furnished by Bradley are shown in broken lines.
2. Supply lines for one to two washfountains should be 1"; for three washfountains 1-1/4"; for more than three washfountains, pipe sizes should be increased proportionately.
3. Overhead supplies must be reduced to 1/2" copper tube to pass through support tube.
4. Check valve inlets are 1/2" NPT.
5. Dimensions shown in parentheses are millimeters.

## Rough-In Specifications *continued* . . .

### Type B

Centrally Rising Vent With Supplies From Above

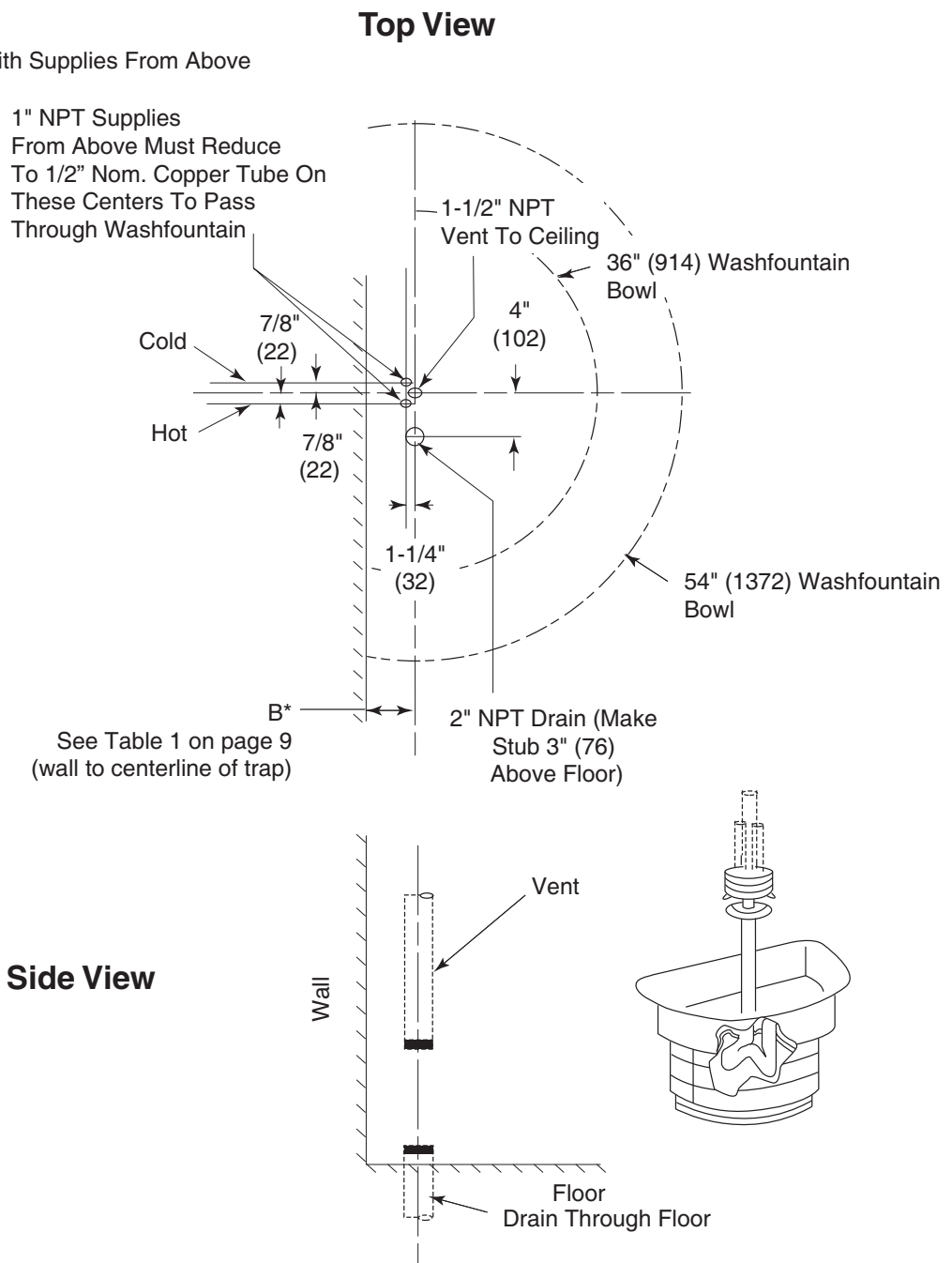

#### Rough-In Notes:

1. All pipes and fittings not furnished by Bradley are shown in broken lines.
2. Supply lines for one to two washfountains should be 1"; for three washfountains 1-1/4"; for more than three washfountains, pipe sizes should be increased proportionately.
3. Overhead supplies must be reduced to 1/2" copper tube to pass through support tube.
4. Check valve inlets are 1/2" NPT.
5. Dimensions shown in parentheses are millimeters.
6. For maximum rigidity of sprayhead/support tube assembly, use 1-1/2" NPT galvanized pipe for vent. Use of plastic or copper for vent is not recommended.

## Rough-In Specifications *continued* . . .

### Type H

Centrally Rising Vent With Supplies From Below

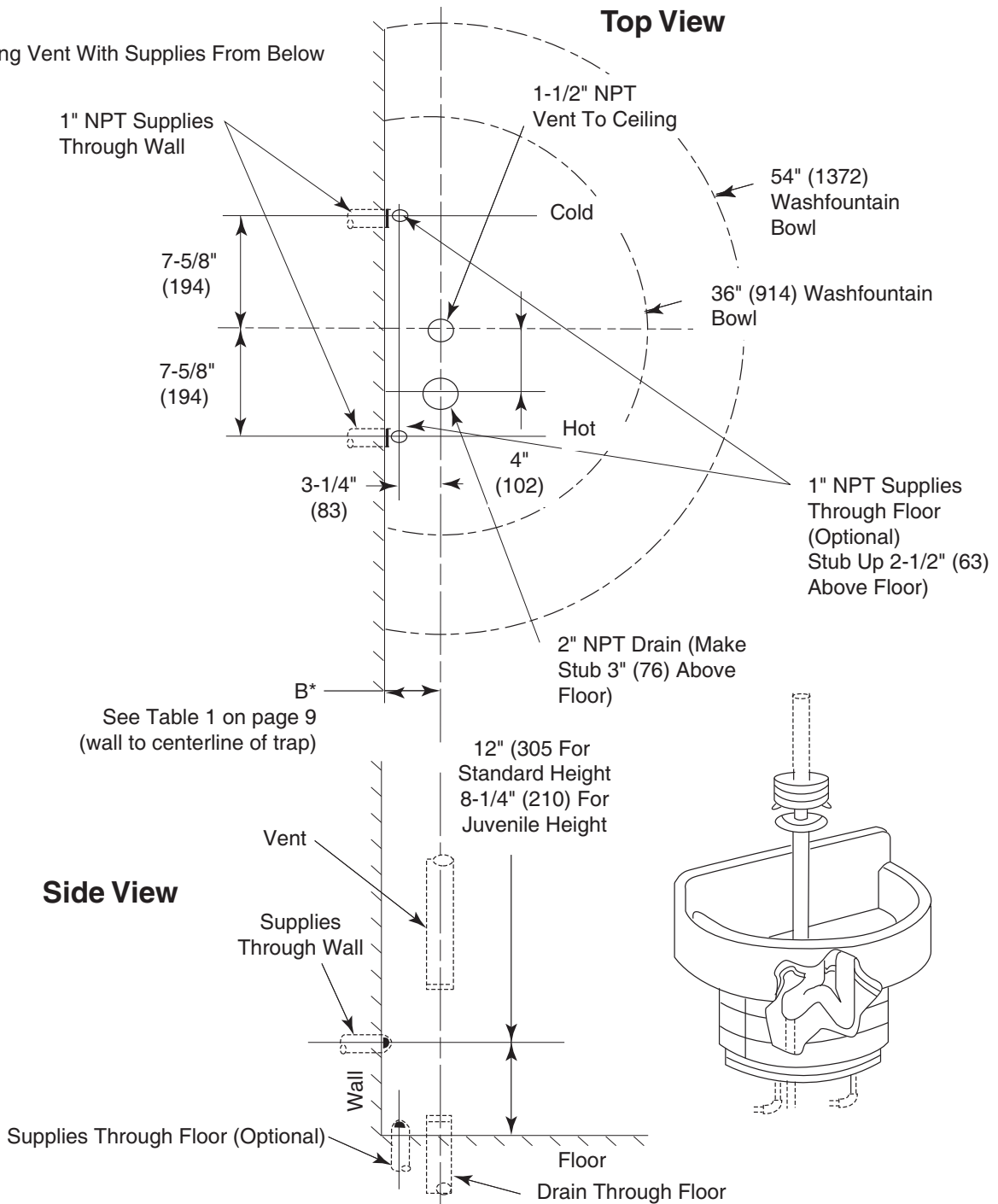

#### Rough-In Notes:

1. All pipes and fittings not furnished by Bradley are shown in broken lines.
2. Supply lines for one to two washfountains should be 1"; for three washfountains 1-1/4"; for more than three washfountains, pipe sizes should be increased proportionately.
3. Overhead supplies must be reduced to 1/2" copper tube to pass through support tube.
4. Check valve inlets are 1/2" NPT.
5. Dimensions shown in parentheses are millimeters.
6. For maximum rigidity of sprayhead/support tube assembly, use 1-1/2" NPT galvanized pipe for vent. Use of plastic or copper for vent is not recommended.



# Installation Instructions

## Step 1: Rough-In of Drain & Supplies

1. Rough in supply and drain piping as required for your installation (see pages 5-8 for rough-ins).
2. Assemble the drain to the dimension shown in Figure 1 or Figure 2 and Table 1 for bowl size of washfountain you are installing.

*NOTE: All piping shown in dotted lines to be supplied by the installer.*

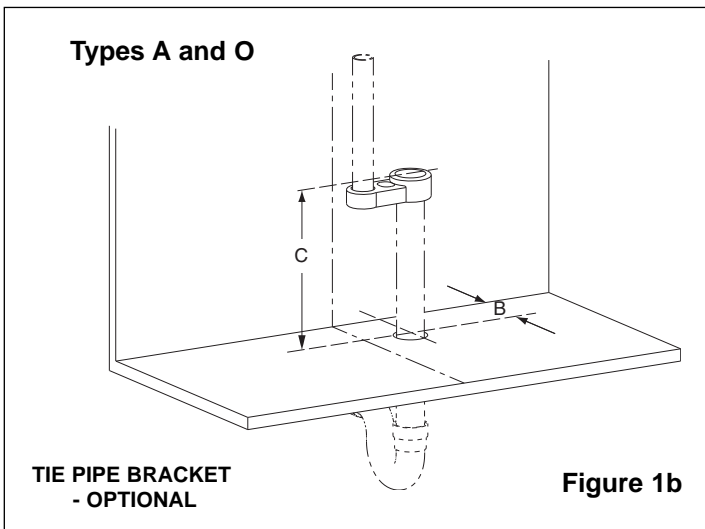
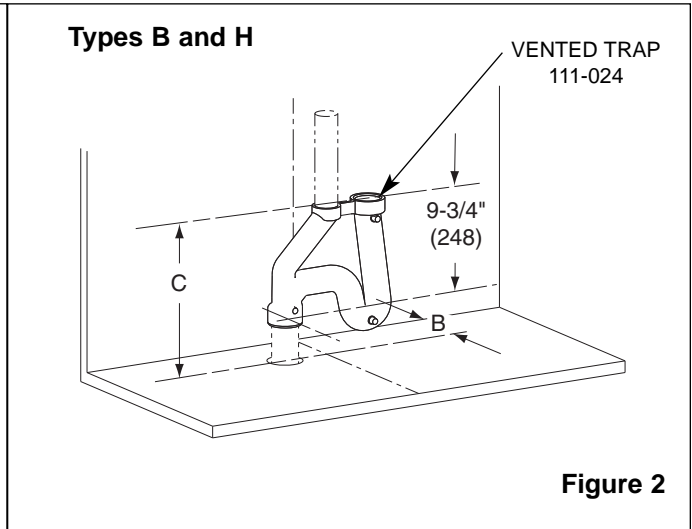
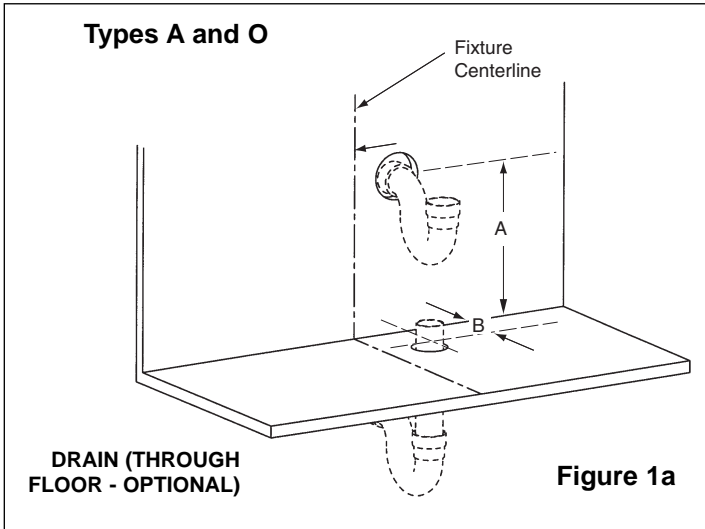

**Table 1 — Trap Dimensions (mm)**

Bowl Material & Size	A		B	C	
	Std. Ht.	Juv. Ht.		Std. Ht.	Juv. Ht.
54" Terrazzo	6" (152) to 13-1/4" (336)	6" (152) to 10-1/4" (260)	5-1/4" (133)	18-5/8" (473)	14-5/8" (371)
36" Terrazzo	6" (152) to 13-1/4" (336)	6" (152) to 10-1/4" (260)	4-3/4" (121)	18-5/8" (473)	14-5/8" (371)
54" Stainless Steel	6" (152) to 11-5/8" (295)	N/A	8-1/4" (210)	17" (432)	N/A
36" Stainless Steel	6" (152) to 12" (305)	N/A	7-3/4" (197)	17-3/8" (441)	N/A

## Installation Instructions *continued . . .*

### Step 2: Assembling the pedestal

1. Assemble the legs and scuff base panels with the 5/16" carriage bolts and nuts provided (Figure 3).
2. Attach the pedestal frame members with the 5/16" stove bolts and nuts provided (see Figure 3).

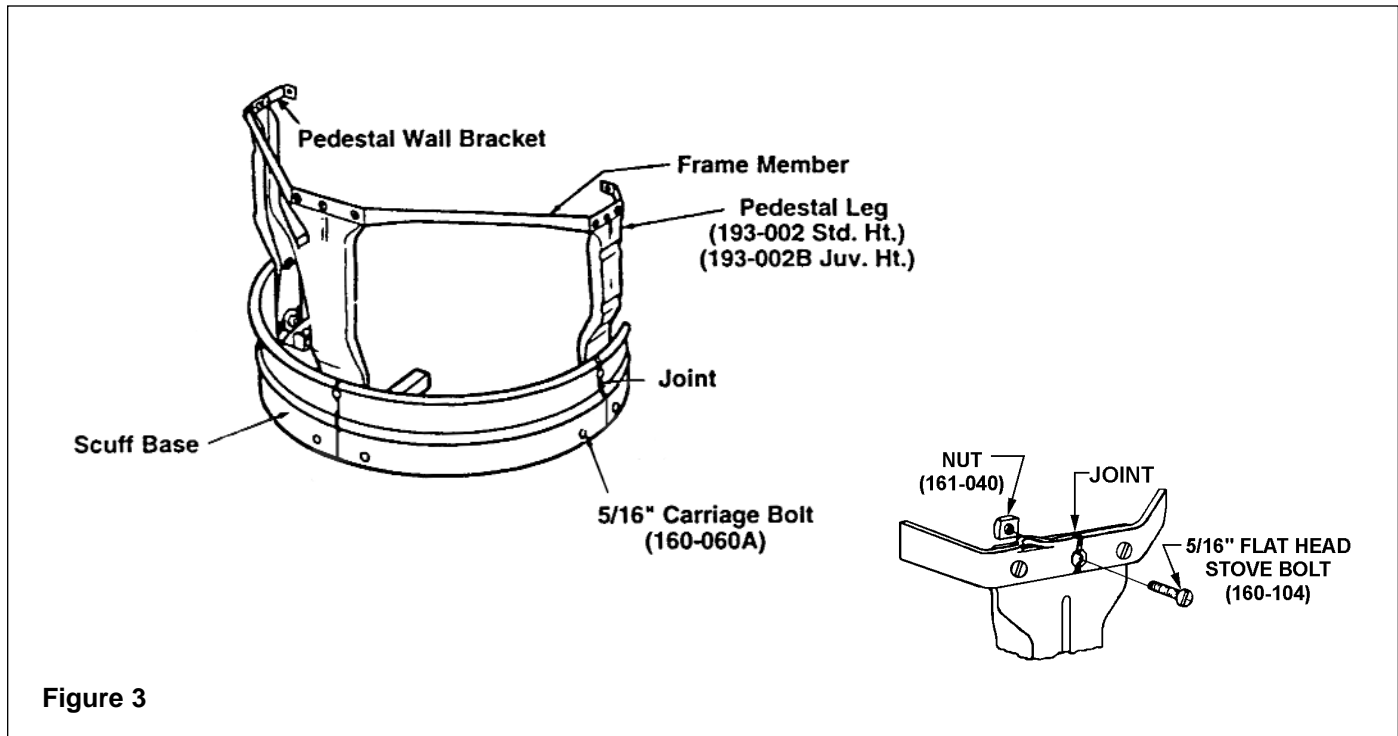

## Installation Instructions *continued . . .*

### Step 3: Bowl and pedestal assembly and mounting

**IMPORTANT:** FOR PROPER DRAINAGE, THE BOWL AND PEDESTAL MUST BE LEVEL WHEN THEY ARE SECURED TO THE FLOOR .

**WARNING:** USE SUITABLE LIFTING EQUIPMENT TO POSITION THE BOWL AND PEDESTAL ASSEMBLY. HANDLE WITH CARE! FAILURE TO DO SO COULD RESULT IN SERIOUS PERSONAL INJURIES.

*NOTE: Refer to Figure 5 and Table 2 for pedestal dimensions.*

#### STAINLESS STEEL BOWL:

1. Place the bowl on the pedestal using suitable lifting equipment.
2. Fasten the bowl to the pedestal with the four flat head stove bolts provided. Place the bowl clip inside the pedestal leg (see Figure 4).
3. Position the bowl and pedestal assembly so that the bowl drain is in line with the trap or drain line (see Figures 1 and 2 on page 9 and Figure 6 on page 12).

*NOTE: There is some spring in the brackets. Adjust the brackets so that the bowl is flush with the wall before securing in place.*

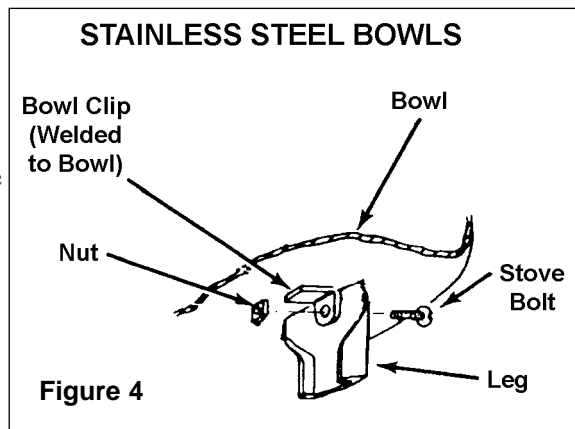

4. Screw the drain spud part of the way into the drain to ensure correct alignment (see Figure 6 on page 12).
5. Anchor the pedestal assembly to the floor and wall with suitable anchors/fasteners (supplied by installer). See Figure 5.

#### TERRAZZO BOWL:

**CAUTION:** Bowl Surface is smooth. Use suitable lifting equipment to position the bowl and pedestal assembly. Handle with CARE!

1. Position the pedestal as shown in Figure 5.
2. Place the bowl on the pedestal using suitable lifting equipment making sure that the bowl drain is in line with the trap or drain line (see Figure 6 on page 12).
3. Anchor the pedestal assembly to the floor and wall with suitable anchors/fasteners (supplied by installer). See Figure 5.

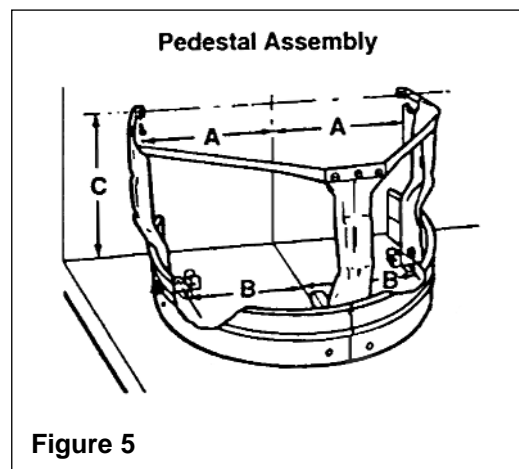

Bowl Material & Size	A	B	C	
			Std. Ht.	Juv. Ht.
36" Terrazzo	11" (279)	8-5/8" (219)	18-1/4" (464)	14-1/4" (362)
54" Terrazzo	16-1/2" (419)	14-1/8" (359)	18-1/4" (464)	14-1/4" (362)
36" Stainless Steel	—	8-5/8" (219)	—	—
54" Stainless Steel	—	14-1/8" (359)	—	—

## Installation Instructions *continued* . . .

### Step 4: Installing drain spud in bowl

*NOTE: Seal between drain spud and drain hole with plumber's putty (supplied by installer).*

1. Secure drain spud with lock nut and washers as shown in Figure 6.

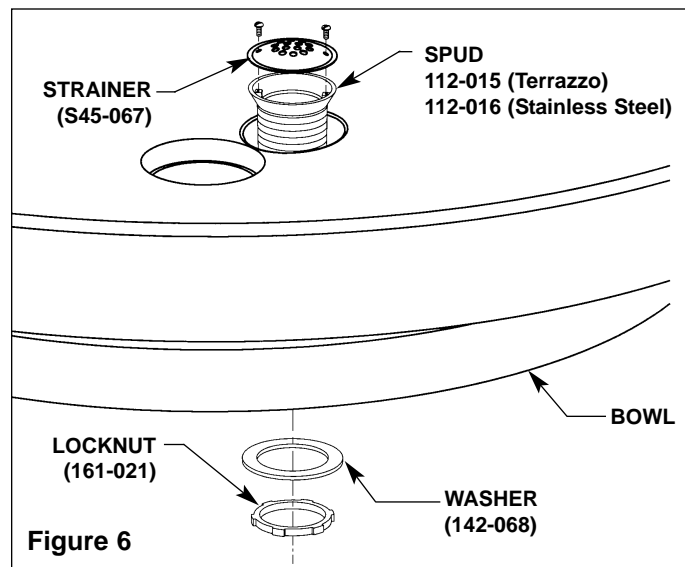

## Installation Instructions *continued* . . .

### Step 5a: Installing Supplies with Optional Soap Dispenser for A/O drain units

*NOTE: See Step 5b on page 15 for Type B/H drain units.*

*NOTE: For models with optional paper towel dispensers, tie pipe assembly, or shroud, see separate instruction sheets and Step 5b for units with type B/H drain.*

1. Install hemmed end (not sharp end) of support tube (welded seam toward wall) with gasket onto bowl as shown in Figure 8 on page 14.
2. Connect 1/2" supply tubing to sprayhead as shown in Figure 7. Follow the procedures below when installing 1/2" tubing into sprayhead to ensure that you achieve a leakproof seal.
  - Using a sharp knife, cut tubing squarely and remove any burrs. *DO NOT* pinch or crush end of tubing.
  - Loosen nut on fitting. Moisten end of tube and push into fitting until it is firmly seated. Tighten nut to secure tube to fitting (make sure nut is securely tightened).
  - If connector leaks, reseal tubing according to above procedure. If leaking persists, replace male connector, or call your Bradley representative for assistance.
3. Place sprayhead with 1/2" tubing onto support tube as shown in Figure 8. Run tubing down through support tube. *Make sure spray holes point away from the wall.*
4. Assemble the lower tie rod (the longer threaded rod), upper tie bar (notched at corners), lower tie bar, tie rod nut, and coupling nut, then attach the 4-1/4" tie rod to coupling nut as shown in Figure 8. Upper tie bar must be parallel to wall.
5. Place air module assembly on top of sprayhead. Rotate until module locks in with tie bar with pushbutton facing front of bowl. Run 1/8" tubing through the support tube into the pedestal.
- 6a. **FOR UNITS WITH SOAP OPTION:** Install the spacer, soap dispenser and dispenser cover and restraining bracket using the coupling nut, third tie rod (8-5/8" long) and second coupling nut as shown in Figure 8. Secure with acorn nut and socket head set screw. The tab on the restraining bracket should fit in a notch in the dispenser cover (see Figure 8).
- 6b. **FOR UNITS WITHOUT SOAP OPTION:** Secure module cover and dispenser cover and restraining bracket with acorn nut and socket head set screw. The tab on the restraining bracket should fit in a notch in the dispenser cover (see Figure 8).
7. Continue installation with Step 6 on page 17.

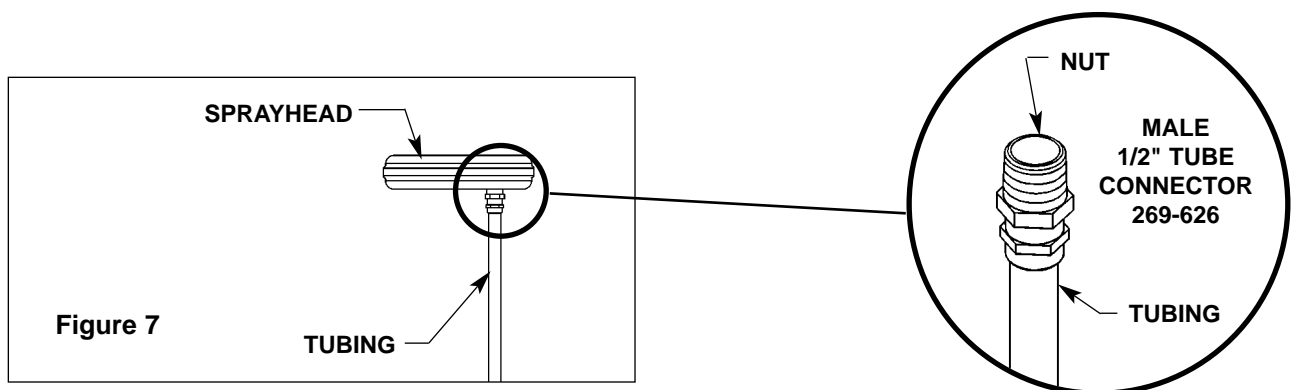

# Installation Instructions *continued* . . .

**TYPE "O" DRAIN**  
 (Supplies from above)

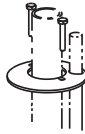

ACORN NUT & SET SCREW  
 (110-052A) (160-093)

**TYPE "A" DRAIN**

DISPENSER COVER

TAB FITS INTO DISPENSER COVER

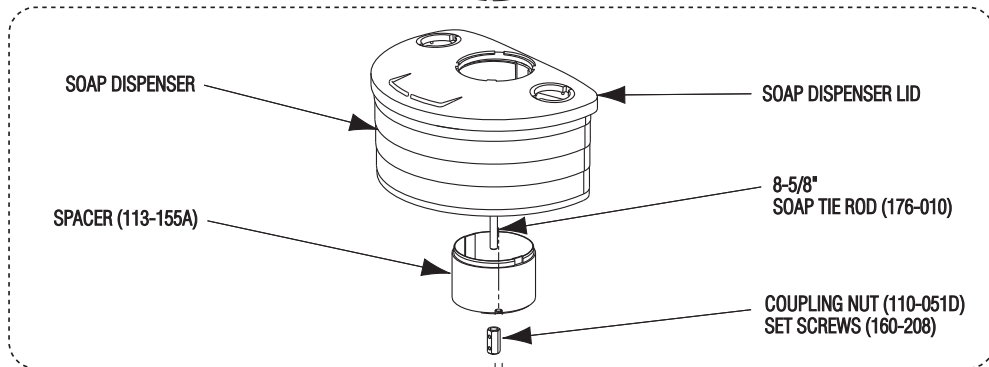

PARTS SHOWN IN  
 BOX ARE FOR UNIT  
 WITH SOAP  
 DISPENSER.

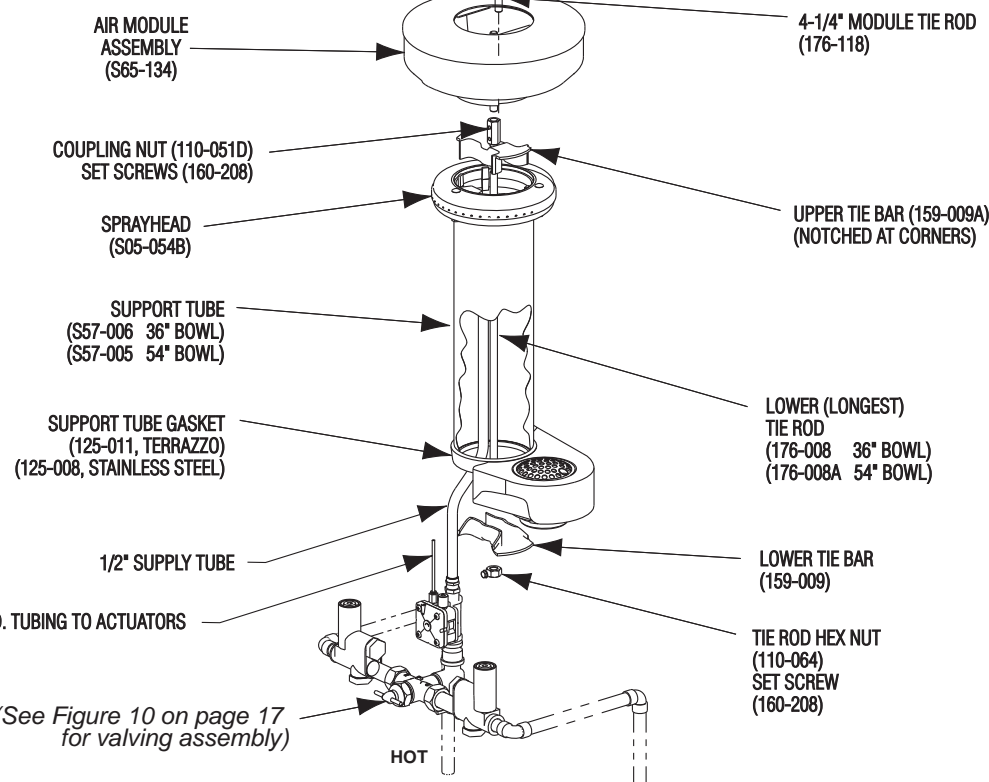

(See Figure 10 on page 17  
 for valving assembly)

HOT

COLD

**Figure 8**

## Installation Instructions *continued* . . .

### Step 5b: Installing Supplies with Optional Soap Dispenser for B/H drain units

1. Install hemmed end (not sharp end) of support tube (welded seam toward wall) with gasket onto bowl as shown in Figure 9 on Page 16.
2. Connect 1/2" supply tubing to sprayhead as shown in Figure 7 on page 13. Follow the procedures below when installing 1/2" tubing into sprayhead to ensure that you achieve a leakproof seal.
  - Using a sharp knife, cut tubing squarely and remove any burrs. DO NOT pinch or crush end of tubing.
  - Loosen nut on fitting. Moisten end of tube and push into fitting until it is firmly seated. Tighten nut to secure tube to fitting (make sure nut is securely tightened).
  - If connector leaks, reseal tubing according to above procedure. If leaking persists, replace male connector, or call your Bradley representative for assistance.
3. Place sprayhead with 1/2" tubing onto support tube as shown in Figure 9. Run tubing down through support tube. *Make sure spray holes point away from the wall.*
4. Place air module assembly on top of sprayhead. Make sure pushbutton is facing the front of the unit.
5. Run 1/8" tubing through the support tube and down into the pedestal.
6. Insert the 1-1/2" vent pipe (supplied by installer, see page 4 for length) through the air module, sprayhead, and support tube.
7. Connect to vented trap provided.
- 8a. **FOR UNITS WITH SOAP OPTION:** Place the spacer, soap dispenser and cover in position on top of air module (see Figure 9). Slide tie bar over 1-1/2" vent pipe 1/2" below top of soap dispenser lid and secure with set screws (tie bar must be parallel to wall). Slide the dispenser cover over 1-1/2" vent pipe and secure with 2 screws included with tie bar.
- 8b. **FOR UNITS WITHOUT SOAP OPTION:** Slide tie bar over 1-1/2" vent pipe, 1/2" below top of air module and secure with set screws (tie bar must be parallel to wall). Slide the dispenser cover over 1-1/2" vent pipe and secure with 2 screws included with tie bar.
9. Connect vent pipe to vent through ceiling with pipe union.
10. Continue installation with Step 6 on page 17.

Installation Instructions *continued . . .*

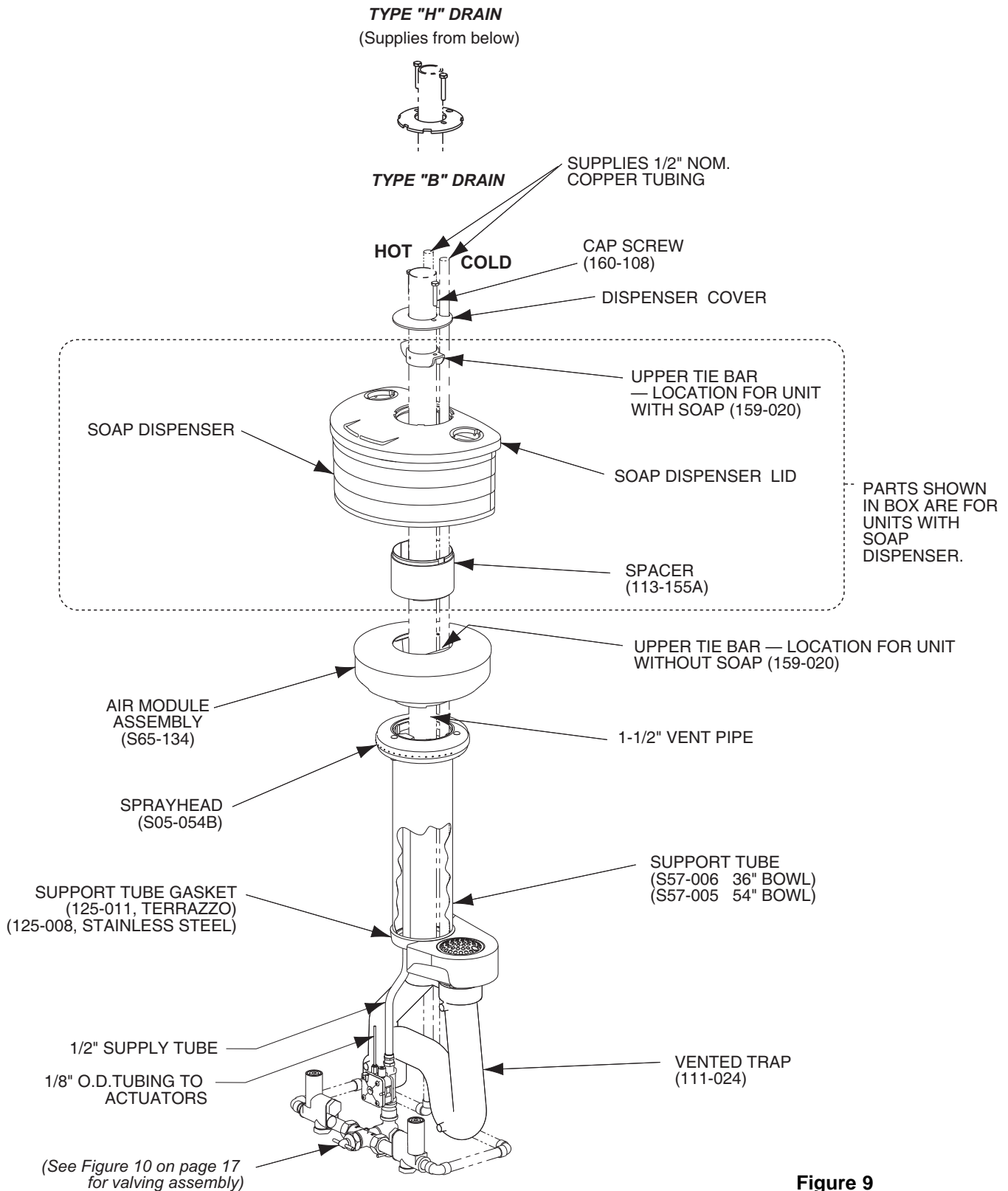

**Figure 9**



## Installation Instructions *continued* . . .

### Step 6: Valve Connections for Air Valve

*NOTE: Flush supply lines before making connections.*

1. Connect the stop-strainer-check valves, mixing valve, volume control valve and air valve assembly to the supplies. Use pipe sealant to seal threads.
3. For overhead supply lines, install 1/2" nominal copper supply tubing by passing the lines through the holes in the dispenser cover and then down through the support tube.
3. Using suitable fittings, install the complete valve assembly to the supplies as shown in Figure 10 at the approximate height indicated in Table 3.
4. Connect the 1/2" supply tubing from the sprayhead to the male connector in the air valve assembly.
5. Connect the 1/8" tubing from the actuator to the air valve (Figure 10).

*NOTE: Insert the end of the tubing into the connector until it is firmly seated on the tube stop (See Figure 11)*

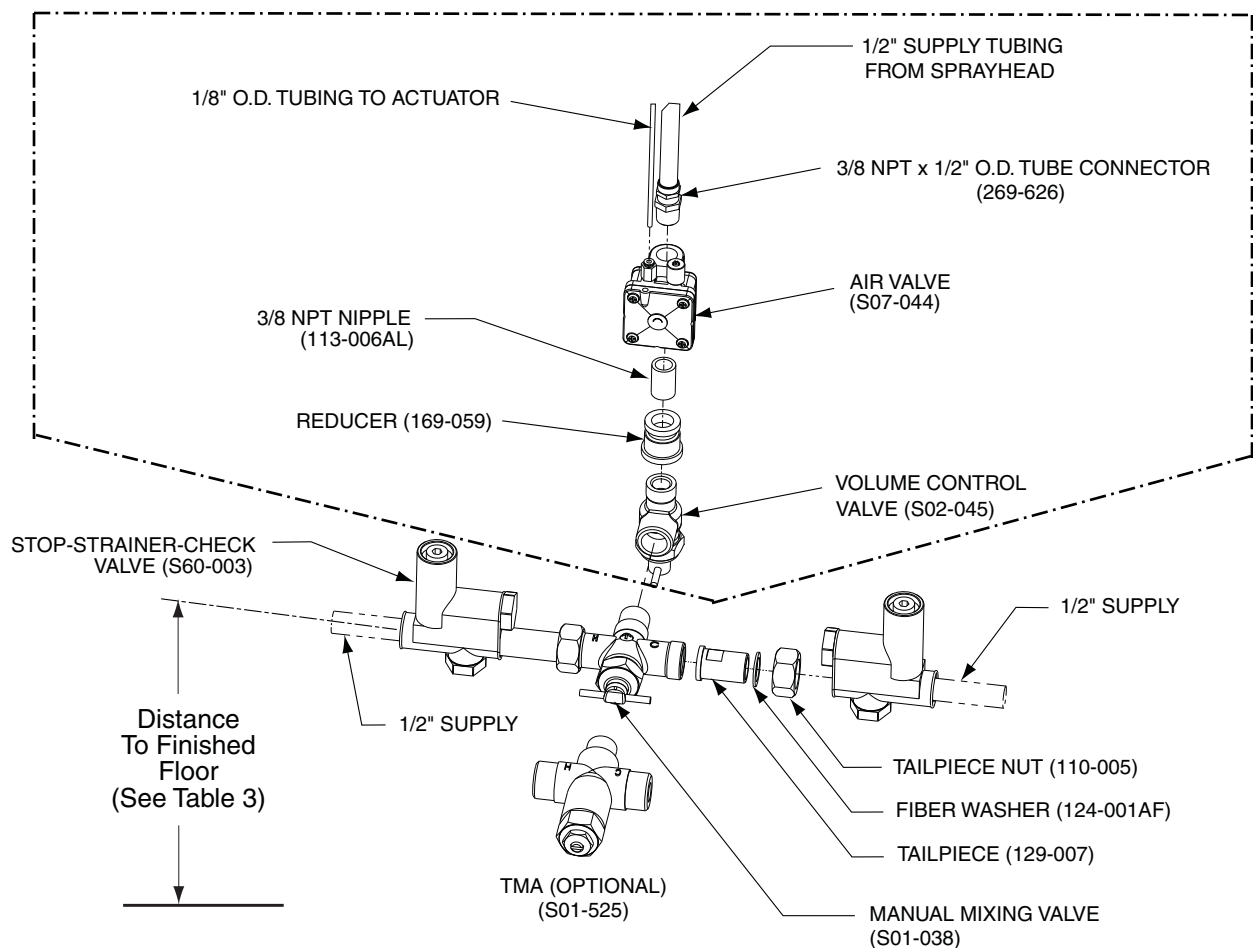

**Figure 10**

Table 3 — Distance from 1/2" Supply to Finished Floor				
Model Number	Type A	Type B	Type O	Type H
Standard Height	9" (229mm)	6-3/16" (157mm)	9" (229mm)	6-3/16" (157mm)
Juvenile Height	5-1/4" (133mm)	3-7/16" (87mm)	5-1/4" (133mm)	3-7/16" (87mm)

## Installation Instructions *continued* . . .

### Step 7: Adjust the air valve metering time

*Note: The air valve timer is located next to the tube connector on the air valve body. The timer is capped with a filter to prevent dirt build-up on the timer. The air valve timing can be adjusted from 5-45 seconds. Refer to Figure 12 when adjusting the air valve.*

1. Remove the filter cap. Use a screwdriver to tighten or loosen the timer. Turning the timer clockwise increases the time, turning the timer counterclockwise decreases the time.
2. Continue to adjust the timer until it is set at the desired length.
3. Replace the filter cap.

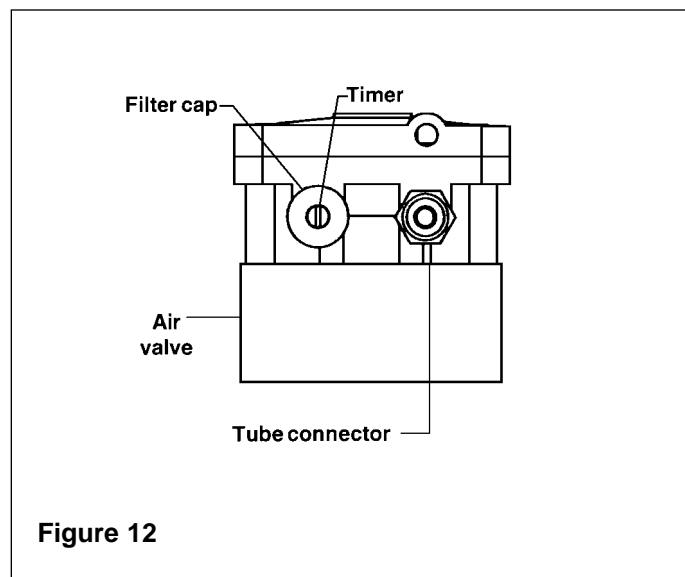
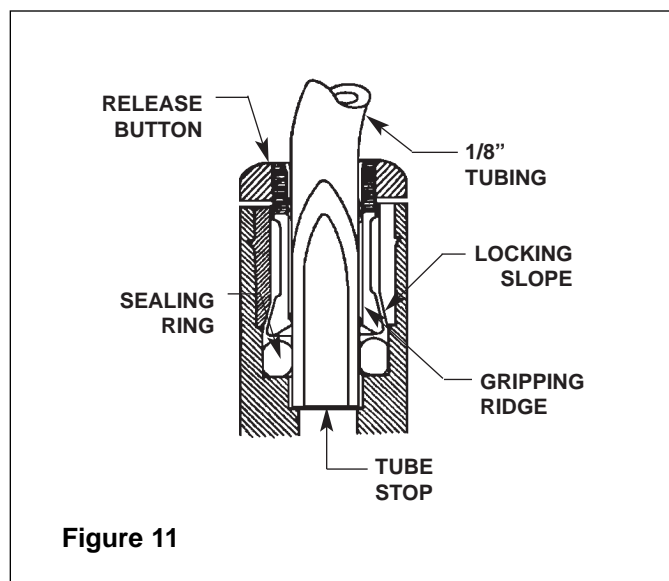

## Air Valve Troubleshooting

**Problem: Valve will not shut off.**

*Cause: Timing mechanism is clogged.*

Solution: Clean and inspect timing mechanism:

1. If compressed air is available, blow water and debris from perforated metal sleeve of timing mechanism.
2. Turn adjusting screw in all the way but do not force screw.
3. Turn adjusting screw out to desired cycle time.

**Problem: Valve will not turn on.**

*Cause: Water is not being supplied to unit.*

Solution: Open all stops on mixing valve.

**Problem: Timing can not be adjusted for more than 5 seconds.**

*Cause: There is an air leak*

Solution: Check the valve assembly:

1. Check all tubing and fittings for proper assembly.
2. Tighten all screws which hold valve together.

**Problem: Push button does not work properly.**

*Cause: Air volume may not be sufficient to operate valve.*

Solution: Check for leaks and lubricate U-cup:

1. Check all fittings for air leaks.
2. Disassemble pushbutton and lubricate U-cup seal.

**Problem: Water is dripping from the aerator.**

*Cause: Debris has accumulated on valve seat or orifices.*

Solution: Clean and inspect valve seat.

1. Remove screws and disassemble metering valve.
2. Clean valve seat and inspect for deep gouges or scratches. Replace if necessary.
3. Remove all debris that may be clogging center hole of plastic diaphragm assembly.
4. Remove any debris clogging off-center hole in rubber diaphragm.

## Check Valve Troubleshooting

**If water just dribbles or does not flow from sprayhead:**

1. Turn off water supplies to fixture.
2. Inspect check valves for proper installation. See Stop, Strainer and Check Valve on page 22.
3. Open the stops and clean the strainers, if necessary.

**If water sprayhead delivers all hot or cold water:**

1. Turn off water supplies to fixture.
2. Inspect check valves for proper installation.
3. Open the stops and clean the strainers, if necessary.
4. Inspect mixing valve for proper installation (see Vernatherm valve on page 28).

### Air Valve Repair Kits and Parts List

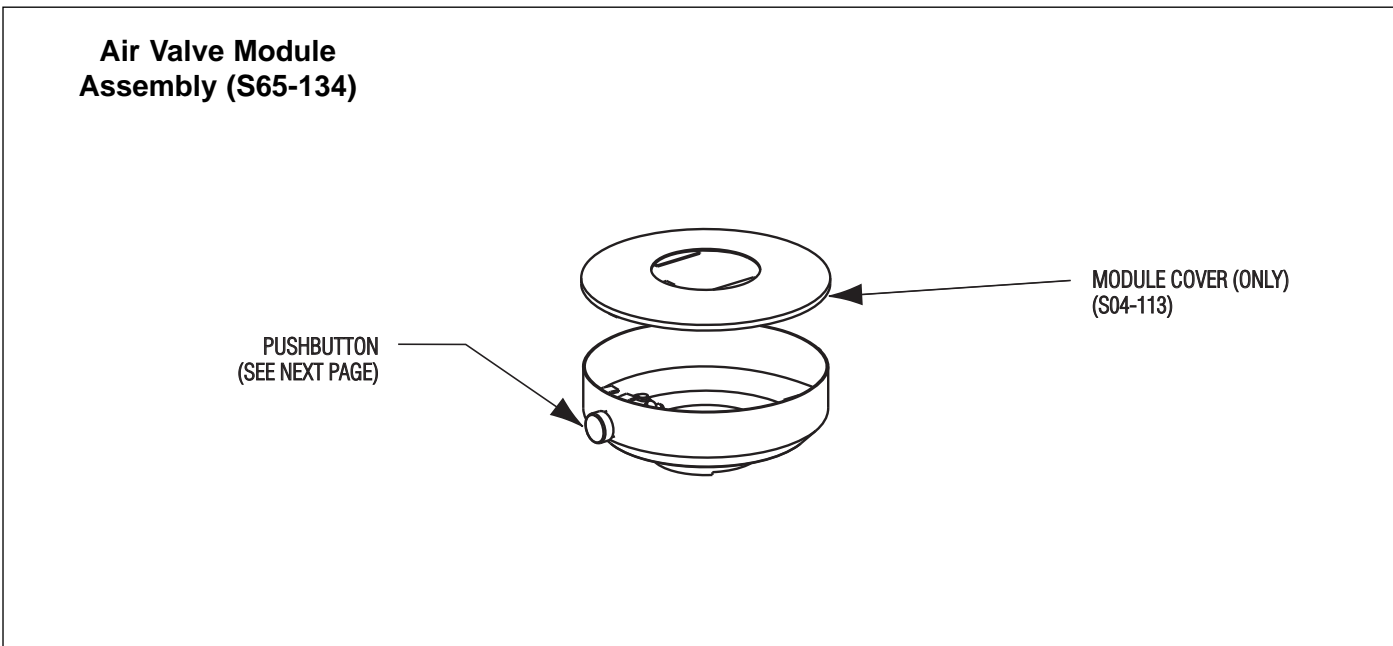
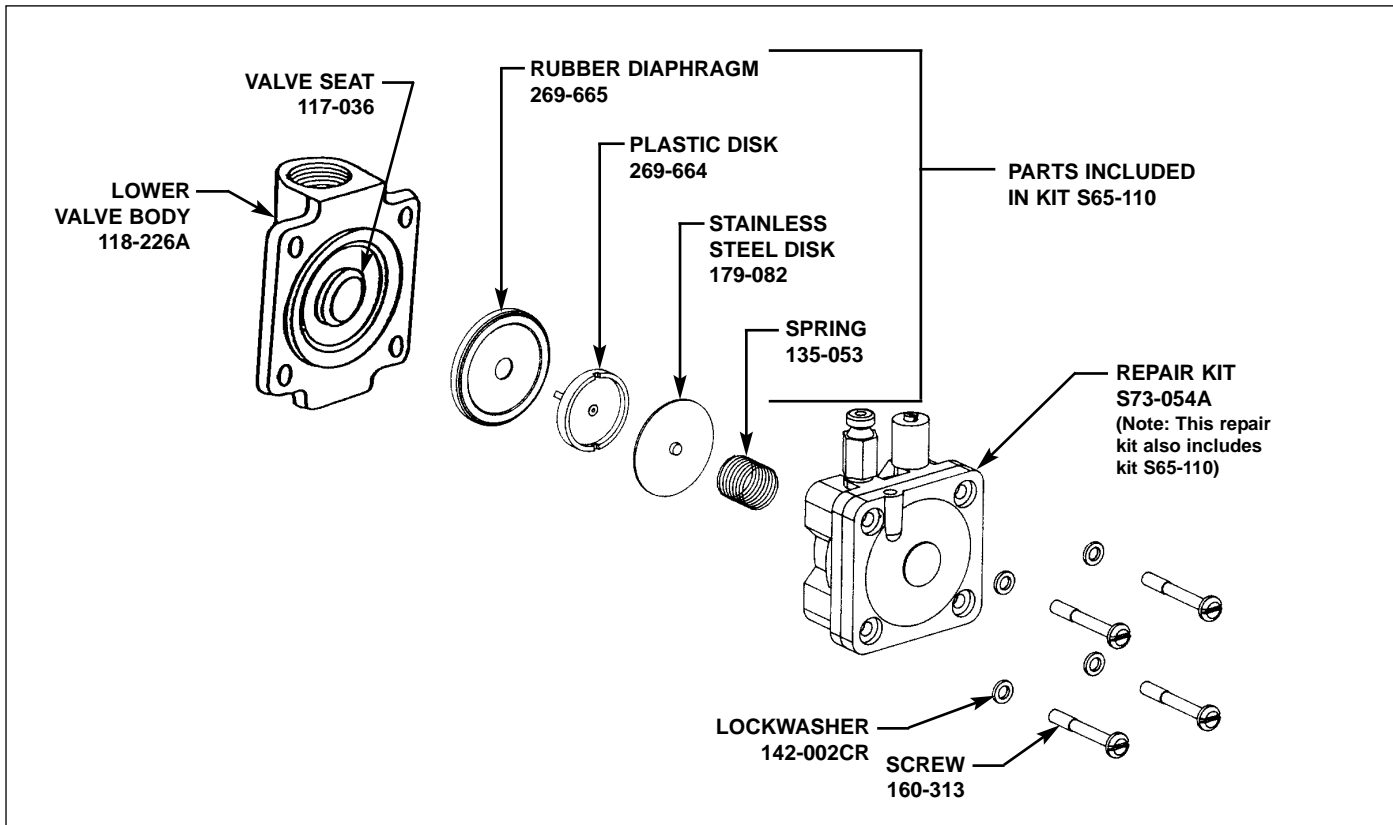

## Actuator Module Assembly Components

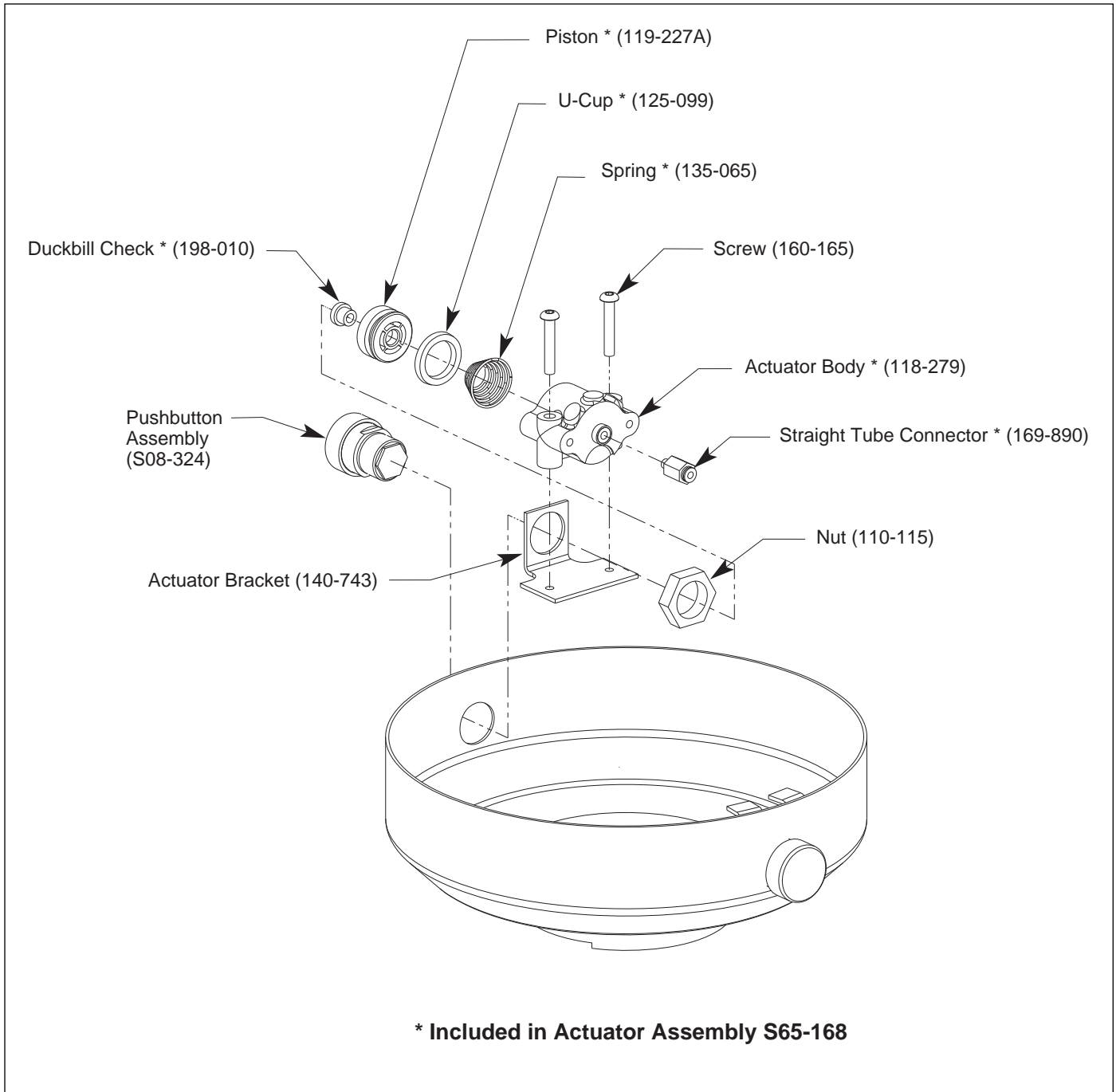

## Stop, Strainer and Check Valve

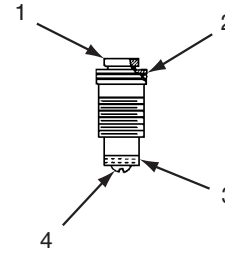
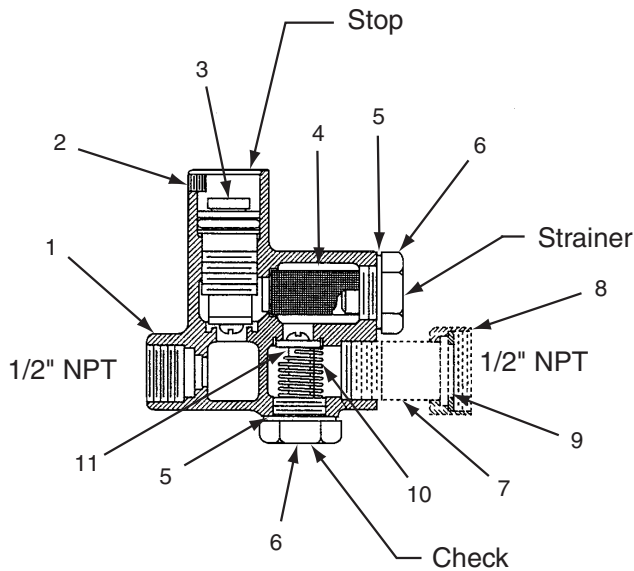

**Parts List** Stop Assembly S21-014  
Standard Celcon Core

Item	Part No.	Qty	Description
1	119-057	1	Valve Core
*2	125-001AW	1	"O" Ring
*3	125-001L	1	Bibb Washer
4	160-164	1	Screw

**Parts List** S60-003 Stop, Strainer and Check Valve

Item	Part No.	Qty	Description
1	118-039	1	Valve Body - Brass
1	118-039A	1	Valve Body - Plated
2	160-131	1	Set Screw
3	S21-014	1	Stop Assembly - Celcon
3	S21-026	1	Stop Assembly - Brass
*4	156-006	1	Strainer
*5	124-001BV	2	Fiber Washer
*6	153-068	2	Plug - Brass
7	129-007	1	Tail Piece - Brass
7	129-007A	1	Tail Piece - Plated
8	110-005	1	Tail Piece Nut - Brass
8	110-005A	1	Tail Piece Nut - Plated
*9	124-001AF	1	Tail Piece Washer
*10	135-001AB	1	Spring
*11	S21-015	1	Check Assembly

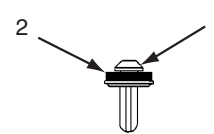

**Parts List** Check Assembly S21-015\*

Item	Part No.	Qty	Description
1	119-091	1	Plunger
2	125-001BB	1	Washer

\* S45-050 Repair Kit Includes these parts

## Soap Recommendations and Maintenance Tips

Quality soap dispensers require good quality soap and periodic maintenance to properly operate. Bradley soap dispensers will provide dependable, consistent operation over the long term when soap with reasonable viscosity and pH levels are used and when a minimal amount of periodic maintenance is performed on the valves.

Soap thickness is determined by a measurement called viscosity. Soap viscosity should be between 100 cps (centerpoise) and 2500 cps for all Bradley soap dispensers. Thinner soaps are perceived by the users as being “watered down” so users tend to take more than they need, resulting in waste. *Thick soaps flow slower and inhibit the “flushing” action of the valves, which allows the soap to congeal in the valve and cause clogs.*

The pH (acid) level of the soap should be in the range of 6.5 to 8.5. More acidic soaps (pH levels lower than 6.5) will corrode metal parts (even stainless steel!!) and degrade rubber and plastic components. They will also cause skin irritation. *Most inexpensive soaps (typically the pink lotion type) fall into this acidic category and will eventually cause valve failure and metal corrosion.* Base soaps (pH levels higher than 8.5) will cause swelling or degradation of rubber and plastic parts and skin irritation.

Generally, any quality soap meeting the viscosity and pH guidelines above will work well with Bradley soap dispensers. PCMX or Isopropanol based antibacterial soaps (within viscosity and pH limits) will also work with Bradley dispensers. Soaps satisfying these basic guidelines will provide consistent flow and reduce clogs.

Most soap dispenser problems are caused by soap that is too thick or corrosive, or by a lack of maintenance. Many soaps come in concentrate form which must be diluted with water. Often, the soap is improperly diluted or used straight out of the bottle, which causes clogging and valve failure. If proper soap is being used, valves that have never been cleaned are usually the source of dispensing problems. Bradley has entered into an agreement with Champion Brand Products to provide additional customer service for purchasers of our dispensers regarding soap issues. They are very helpful and can get to the bottom of almost any soap dispenser-related problem. They also sell an excellent “Bradley approved” soap. Please see Bradley Instruction sheet 215-1286 for soap valve cleaning details and Champion Brand Products contact information.

## Soap Valve - Liquid - S09-007S

This valve delivers a measured amount of soap with each upward stroke. The soap dispenser has been standard on washfountains since 1983 and is not well-suited for very thick lotion soaps.

*NOTE: Lotion soap will clog liquid soap valves. Use only lotion soap valves with lotion soap.*

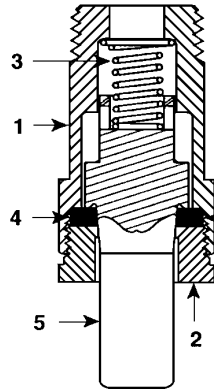

### Parts List

\* Not Illustrated

Item	Part No.	Description	Attaching Parts S09-007S	
			Qty	
1	118-025	Valve Body	1	
2	110-007	Packing Nut	1	
3	135-001L	Spring	1	
4	125-001BU	Washer	1	
5	119-028	Plunger	1	
*	161-014	Nut	1	
*	124-001D	Washer	2	
*	142-002AH	Washer - Stainless Steel	1	

## Soap Valve - Lotion - S09-057S Parts List

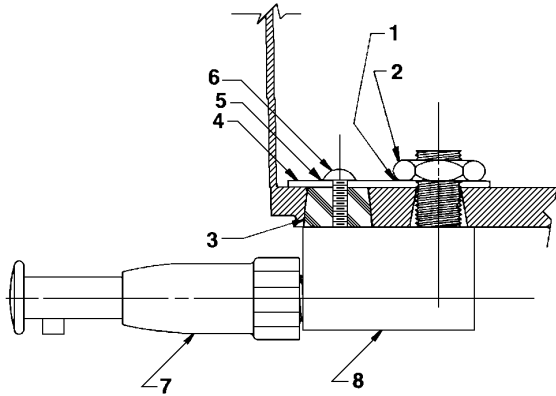

Item	Part No.	Description	Valve Assembly S09-057	Attaching Parts S09-057S
			Qty	
1	124-001D	Washer	—	1
2	110-057	Nut	—	1
3	125-001AN	Stopper	—	1
4	159-114	Reinforcing Plate	—	1
5	124-001AT	Washer	—	1
6	160-176	Screw	—	1
7	S09-040	Valve	1	1
8	S53-045	Adapter	1	1

## Soap Valve - Powdered - S09-010A

### Parts List

Item	Part No.	Qty	Description
1	160-069	1	Screw, 1/4-20 RD
2	142-002X	1	Washer, 1/4 Split-Lock
3	S62-002	1	Agitator / Slide Assy.
4	192-004	1	Lever - Powdered Soap

*NOTE: Reducer plugs are available for use with fine granulated soap to reduce the flow.*

*NOTE: Valves can be changed from powdered to liquid by plugging the innermost, or "bearing" hole with rubber plug, part number 125-001AK. To change from liquid to powdered, the plug must be removed. If none is present, it will be necessary to drill out the bearing hole with a 1/2" or 5/8" drill. The plastic container configuration forms a natural template for locating the bearing hole.*

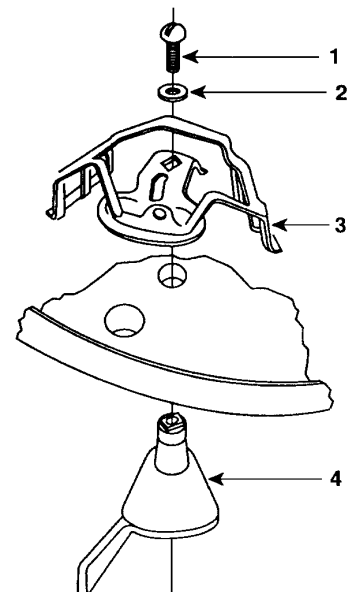



## Sprayhead Troubleshooting and Repair Parts

### Problem: Water splashes over the rim of the bowl.

*Cause: Foreign matter has reduced the size of the sprayhead slots, causing greater pressure at the open slots.*

Solution: Clean the sprayhead:

1. Disassemble the sprayhead and dislodge any dirt, lime build-up and foreign debris with a wire brush.
2. Sprayheads with rubber grommet spray rings may be cleaned by rubbing a coin over the grommet.
3. Throttle down the volume control (water spray should strike the bowl without splashing outside of the bowl).

### Problem: Water flow diminishes from the sprayhead.

*Cause: Strainer portion of the stop-strainer-check valve is plugged.*

Solution: Remove and clean the strainer screen from the stop-strainer-check valve.

*NOTE: The sprayhead shown below includes a perforated rubber spray ring grommet that is self-cleaning. The water pressure flexes the spray holes which slows accumulation of foreign matter and tends to "break loose" any such deposits that may have accumulated.*

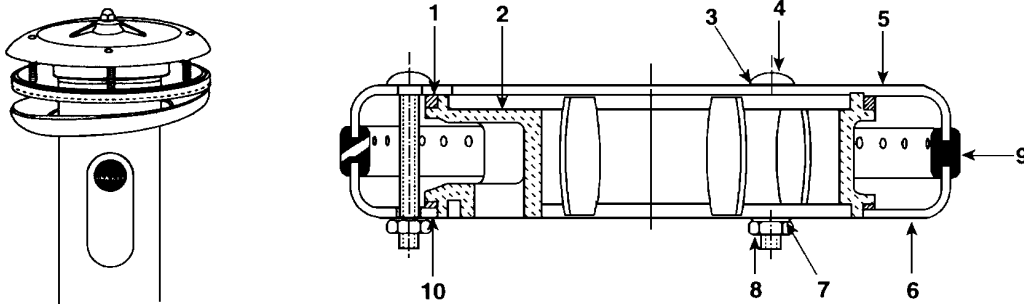

## Parts List

Item	Part No.	Description	Sprayhead Assembly S05-054B	Repair Kit S45-051
			Qty	
1	125-001DE	Neoprene Washer-Top	1	1
2	139-031	Sprayhead Manifold	1	—
3	124-001AL	Washer	3	4
4	160-211	Carriage Bolt	3	4
5	115-061	Sprayhead Top	1	—
6	116-008	Sprayhead Bottom	1	—
7	124-001AT	Washer	3	4
8	161-025	Nut	3	4
9	124-020D	Sprayhead Grommet - Semi-circle	1	—
10	125-001DF	Neoprene Washer-Bottom	1	1

## Manual Mixing Valve Repair Parts

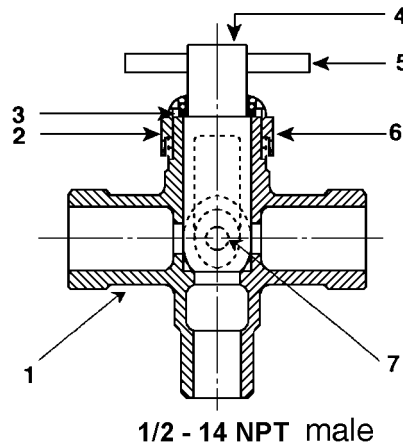

## Manual Mixing Valve Parts List

Item	Part No.	Description	Valve Assembly S01-038	Valve and Tailpieces S01-038S	Repair Kit S45-197
			Qty		
1	118-034	Mixing Valve Body - Brass	1	1	—
1	118-034A	Mixing Valve Body - Chrome	—	—	—
2	124-001BD	Fiber Washer	1	1	1
3	125-001BC	O-Ring	1	1	1
4	119-059	Mixing Valve Core	1	1	1
5	152-038	Roll Pin	1	1	1
6	121-016	Bonnet - Brass	1	1	1
6	121-016A	Bonnet - Chrome	—	—	—
7	160-197	Screw - Brass	1	1	—
7	160-189	Screw - Stainless Steel	—	—	—
*	129-007	Tailpiece - Brass	—	2	—
*	110-005	Tailpiece Nut - Brass	—	2	—
*	129-007A	Tailpiece - Chrome	—	—	—
*	110-005A	Tailpiece Nut - Chrome	—	—	—
*	124-001AF	Tailpiece Washer	—	2	2

\* Parts not shown

## Volume Control Valve Repair Parts

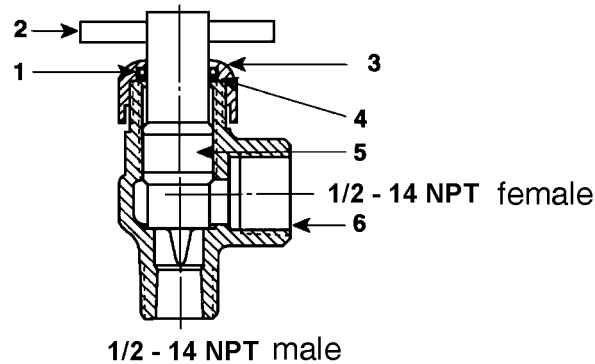

## Volume Control Valve Parts List

Item	Part No.	Description	Brass Valve S02-045	Repair Kit S45-198
			Qty	
1	125-001BC	O-Ring	1	1
2	152-038	Roll Pin	1	1
3	121-016	Bonnet	1	1
3	121-016A	Bonnet	—	—
4	124-001BD	Fiber Washer	1	1
5	119-060	Valve Core	1	1
6	118-033	Valve Body	1	—
6	118-033B	Valve Body	—	—

## Adjusting the Vernatherm Thermostatic Mixing Valve

 **NOTE:** This valve is **NOT** factory preset. Upon installation, the temperature of this valve must be checked and adjusted to ensure delivery of a safe water temperature. **Water in excess of 110°F (43°C) may cause scalding.**

1. Check the temperature when approximately 1.0 GPM water flow is reached and adjust if necessary (the range of the valve is 95°F–115°F (35°C–43°C). To adjust the temperature, follow the procedure below:
  - Loosen temperature locking nut with wrench.
  - Using a blade screwdriver, turn the adjustment stem **counterclockwise** to **increase** the temperature or **clockwise** to **decrease** the temperature (Figure 13).
  - Once desired temperature has been reached, tighten lock nut to prevent change in temperature.
2. Shut the hot water inlet off by closing the hot water stop-strainer-check valve. While the hot water supply is turned off, check to make sure the cold water flow is reduced. If the cold water is reduced properly, reopen the hot water supply.
3. Shut the cold water inlet off by closing the cold water stop-strainer-check valve. While the cold water supply is off, check to make sure that the hot water flow has shut down.

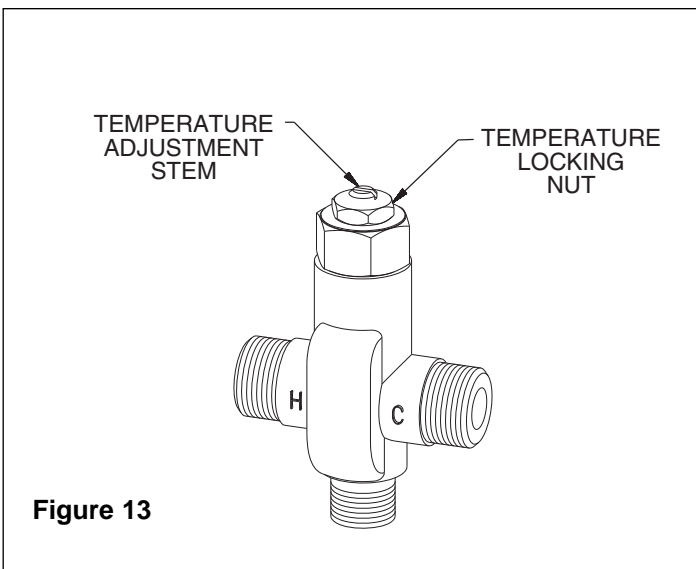

## Thermostatic Mixing Valve Maintenance and Troubleshooting

*NOTE: Before attempting to troubleshoot the valve or disassemble the components, check for the following conditions:*

- *If stop/check valves are used, make sure that they are fully open*
- *Make sure that the hot and cold inlet pipes are connected properly, and that there are no cross-connections or leaking stop/check valves*
- *check the hot water heater output to make sure that it is at least 20° F above the set temperature.*

*Be sure to close the appropriate shut-off valves prior to disassembly of the valve and reopen the valves after inspection and repair is complete.*

### **Problem: Limited water flow**

*Cause: Dirt and debris have built up in the valve.*

Solution: Check the valve's piston for free and smooth movement, follow the procedures outlined below:

1. Remove the valve's cap and thermostat (see Figure 14 on Page 30).
2. Push down on the piston with your finger (the piston should move freely). If the movement is not as it should be, the piston needs to be cleaned. Follow the method outlined below for cleaning the piston and valve body:
  - Remove the thermostat.
  - Lift the piston out with a needle-nose pliers and remove the spring.
  - Any cleaner suitable for brass and stainless steel may be used (if cleaning with suitable cleaner is not sufficient to remove debris, a 400-grit sandpaper may be used to polish and hone the piston and valve body).
  - Snap spring into piston (will detent) and reassemble into the valve body.
  - Retest the piston.
3. If, after a thorough cleaning, the piston does not move freely, the piston must be replaced. Contact your Bradley representative and ask for Repair Kit (part number S65-259).

### **Problem: External leaks in the system**

*Cause: O-rings have been damaged.*

Solution: Replace O-rings where necessary. For replacement of the O-rings, contact your Bradley representative and ask for Repair Kit (part number S65-259).

### **Problem: Improper water temperature or temperature fluctuation**

*Cause: Thermostat is slowly failing or not working at all.*

Solution: "Check the thermostat for proper operation".

1. At room temperature (80° F or less) remove cap and thermostat.
2. Place thermostat into container with 115° F water. The pushrod should pop out of the thermostat approximately 1/10".
3. If thermostat pushrod does not pop out, the thermostat must be replaced. Contact your Bradley representative and ask for Repair Kit (part number S65-259).

*Cause: Valve temperature is not properly set.*

Solution: "Adjust the temperature" per steps on Page 28.

**Vernatherm Thermostatic Mixing Valve (S01-525) Parts List — Repair Kit S65-259**

**Parts List S65-259 Valve Repair Kit**

Item	Part No.	Qty	Description
5	S39-413	1	Thermostat
7	125-001BX	1	O-Ring
8	125-157	1	O-Ring

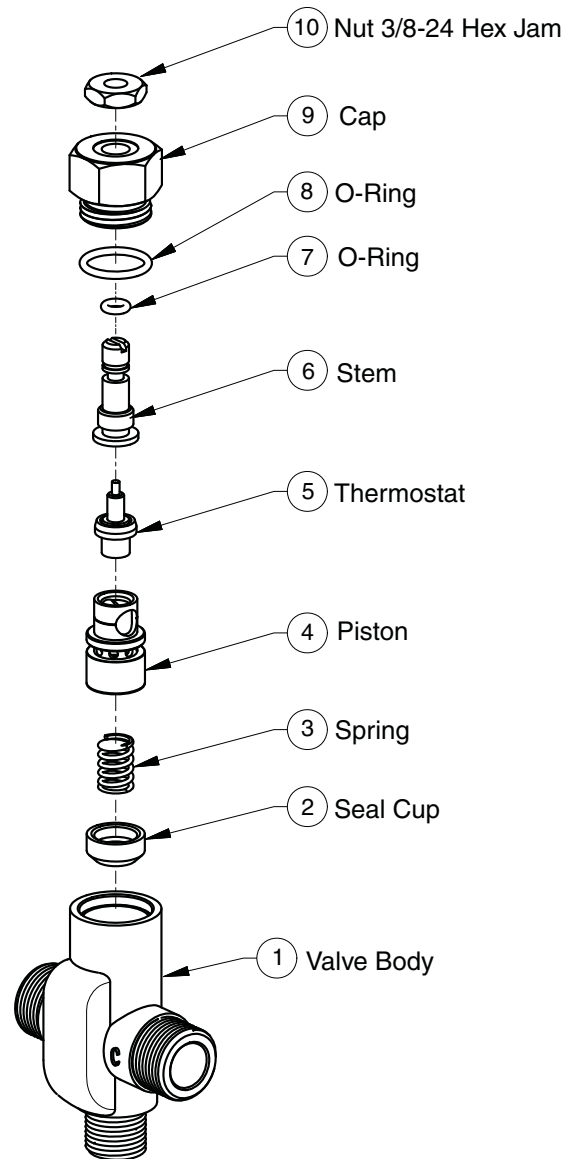

Figure 14

## Cleaning and Maintenance Instructions for Terreon®

**Material Description:** Terreon® is a NAHB Certified densified solid surface material composed of polyester resin and is resistant to chemicals, stains, burns and impact. Surface damage can be easily repaired with everyday cleansers or fine grit abrasives.

**Routine Cleaning:** Clean daily or as often as conditions require using a standard commercial or household cleaner such as Formula 409® or Windex®.

**Stubborn Stains:** Remove tough stains with Ajax®, Comet®, or Soft-Scrub® and a green Scotch-Brite® pad or lightly sand in a circular motion with 240 grit wet/dry sandpaper. The finish can be renewed with a maroon Scotch-Brite pad.

### Special Situations for Material

**Scratches:** Remove scratches with a green Scotch-Brite® pad. The finish can then be renewed with a maroon Scotch-Brite® pad.

**Hard Water Deposits:** Remove hard water deposits with a mild solution of vinegar and water. Always rinse the unit thoroughly after cleaning.

**Restoring the surface:** Use Hope's® Solid Surface cleaner and polish to refresh and protect the Terreon Solid Surface material. Bradley recommends additional care and maintenance for the darker colored Terreon, for complete instructions on this additional maintenance see Bradley document #1505.



**IMPORTANT: DO NOT USE STRONG ACID OR ALKALINE CHEMICALS AND CLEANSERS TO CLEAN TERREON. IF THESE CHEMICALS COME IN CONTACT WITH THE TERREON SURFACE, WIPE THEM OFF IMMEDIATELY AND RINSE WITH SOAPY WATER.**

**AVOID CONTACT WITH HARSH CHEMICALS SUCH AS PAINT REMOVER, BLEACH, ACETONE, ETC. AVOID CONTACT WITH HOT PANS AND OBJECTS.**

**Repair Kits:** Terreon® repair kits are available. Contact your Bradley representative or distributor for part numbers and pricing.

*NOTE: Repair kits are made to order and have a shelf life of 30 days.*

## Cleaning and Maintenance Instructions for Bradstone

Bradstone is impervious to most chemicals and stains. Soap and dirt accumulations should be washed off with detergent cleaners. Abrasives and caustic cleaners are not recommended. An occasional waxing with automotive wax will make future cleaning even easier.

## Cleaning and Maintenance Instructions for Stainless Steel

**Material Description:** Stainless steel is extremely durable, and maintenance is simple and inexpensive. Proper care, particularly under corrosive conditions, is essential. Always start with the simplest solution and work your way toward the more complicated.

**Routine cleaning:** Daily or as often as needed use a solution of warm water and soap, detergent, or ammonia. Apply the cleaning solution per the manufactures instructions and always use a soft cloth or sponge to avoid damaging the finish.

**Stubborn Stains:** To remove stains from stainless steel use a stainless steel cleaner and polish such as Ball® stainless steel cleaner or a soft abrasive. Always follow the manufactures instructions and apply in the same direction as the polish lines.



**IMPORTANT: NEVER USE ORDINARY STEEL WOOL OR STEEL BRUSHES ON STAINLESS STEEL. ALWAYS USE STAINLESS STEEL WOOL OR STAINLESS STEEL BRUSHES.**

### Special Situations for Material

**Fingerprints and Smears:** To remove fingerprints or smears use a high quality stainless steel cleaner and polish in accordance with the manufactures instructions. Many of these products leave a protective coating the helps prevent future smears and fingerprints.

**Grease and Oil :** To remove grease and oil use a quality commercial detergent or caustic cleaner. Apply in accordance to the manufactures instructions and in the direction of the polish lines.

**Precautions:** Avoid prolonged contact with chlorides (bleaches, salts), bromides (sanitizing agents), thiocyanates (pesticides, photography chemicals, and some foods), and iodides on stainless steel equipment, especially if acid conditions exist.



**IMPORTANT: DO NOT PERMIT SALTY SOLUTIONS TO EVAPORATE AND DRY ON STAINLESS STEEL.**

The appearance of rust streaks on stainless steel leads to the belief that the stainless steel is rusting. Look for the actual source of the rust in some iron or steel particles which may be touching, but not actually a part of the stainless steel structure.

*NOTE: Strongly acidic or caustic cleaners may attack the steel causing a reddish film to appear. The use of these cleaners should be avoided.*

**Brand Names:** Use of brand names is intended only to indicate a type of cleaner. This does not constitute an endorsement, nor does the omission of any brand name cleaner imply its inadequacy. Many products named are regional in distribution, and can be found in local supermarkets, department and hardware stores, or through your cleaning service. It is emphasized that all products should be used in strict accordance with package instructions.

### Drain Cleaning

Drains can be cleaned with a plumbers snake inserted through the drain spud after removing the strainer, or through the trap clean out plug



**IMPORTANT: Do not put drain cleaners in bowl. Damage to bowl will result.**