

Installation

LC800

Patient Care Unit, 47", Fixed Water Closet

Table of Contents

Pre-Installation Information	2
Supplies Required	2
Step 1: Water Closet	3
Step 2: LC800 Cabinet	3
Step 3: Push Button Flush Valve	4
Step 4: Backflow Preventer/Bedpan Washer ...	4
Step 5: Countertop	5
Step 6: Faucet and Supplies	5
Cleaning and Maintenance	6

⚠ IMPORTANT! ⚠

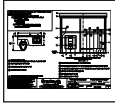

BEFORE beginning installation, all supply, drain and waste piping rough-ins must be completed according to rough-ins received prior to receiving the unit. If you have not received rough-ins, contact your Bradley representative.

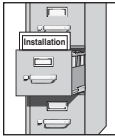

Read this entire installation manual to ensure proper installation. When finished with the installation, file this manual with the owner or maintenance department. Compliance and conformity to local codes and ordinances is the responsibility of the installer. Bradley cannot assume any responsibility for personal injury or damage to equipment due to an improperly installed LC800 unit.

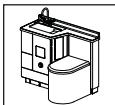

Left-hand model is shown throughout this manual. Installation of right-hand model is opposite. This manual covers all models included in the Bradley LC800 series. Simply omit the steps that do not apply to the model you are installing. For units with a laminate top, remove the top before beginning installation.



Separate parts from packaging and make sure all parts are accounted for before discarding any packaging material. If any parts are missing, do not begin installation until you obtain the missing parts.

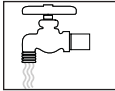

Make sure that all water supply lines have been flushed and then completely turned off before beginning installation. Debris in supply lines can cause valves to malfunction.

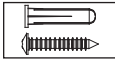

Hardware supplied by installer must be appropriate for wall construction. Wall anchors used must have a minimum pull-out rating of 1,000 lbs.



Product warranties and service parts information may be found on our web site at bradleycorp.com.

Supplies Required:

- (6) 3/8" wall anchors and bolts and washers to secure the cabinet to the wall (minimum pull-out rating of 1,000 lbs.)
- Steel angles and hardware for anchoring the water closet (if concrete is lightweight or less than 4" thick)
- Hardware for waste outlet connections
- Shims (for water closet or cabinet installation, if necessary)
- Water supply piping to water closet, faucet or foot valve, and optional backflow preventer and bedpan washer
- Waste outlet piping to water closet
- P-trap and drain piping
- 5/16" toilet-mounting hardware (for floor-mount option)

1a Floor-Mount Water Closet

For units with optional china water closet, refer to manufacturer's instructions.

A Align water closet waste outlet per rough-in submittal. Using the water closet as a template, drill two 2-1/8" deep holes into the water closet support anchoring locations (use a 5/8" concrete drill bit). Holes must be clean and free of debris.

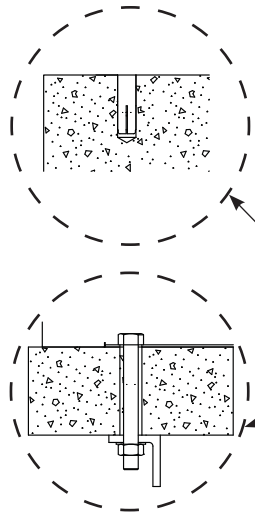

B Remove the water closet. Drive the two 2-1/8" anchors provided into the drilled holes for the water closet using a hammer and the setting tool supplied. The anchor should be driven in flush with the floor.
Install the 1/2" x 2" studs provided into the two 2-1/8" anchors.
IMPORTANT: If the floor concrete is lightweight or less than 4" thick, Bradley recommends through-bolting to the steel angles under the floor.

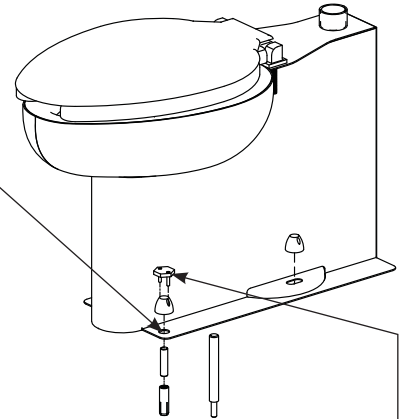

C Place the water closet over the threaded studs. Connect the water closet to the floor or wall waste outlet using a flanged gasket connection.
Secure the 1/2" water closet nuts using the nut driver provided. **NOTE:** 5/16" Acorn nuts also provided for anchoring flange. Additional mounting hardware supplied by installer.

1b Wall-Mount Water Closet

- In-wall carrier is recommended
- Reference submittal for bolt hole pattern
- Mounting hardware supplied by installer

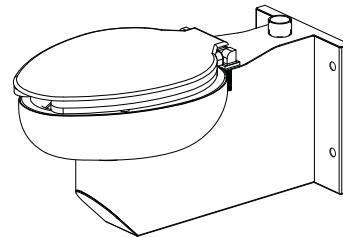

2 LC800 Cabinet

A With assistance, lift the cabinet over the water closet. Secure the cabinet to the back wall in (6) places with 3/8" anchors and fasteners.

For cabinets with laminate countertop option, remove the top prior to installation.

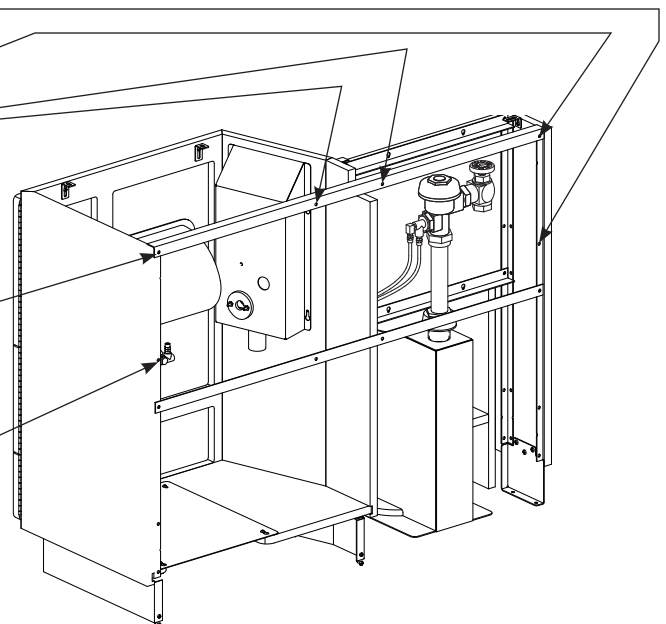

3 Push Button Flush Valve

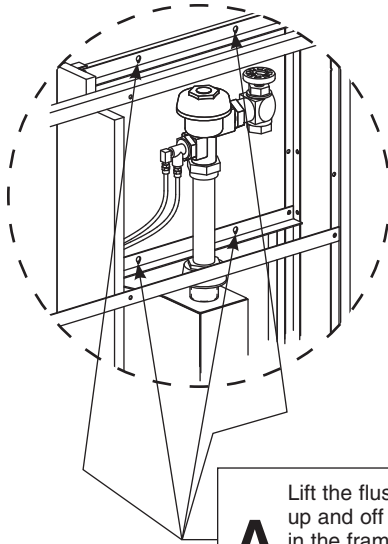

A Lift the flush valve access panel up and off the (4) keyhole slots in the frame. The screws are not tightened flush to the backside panel, allowing for easy removal.

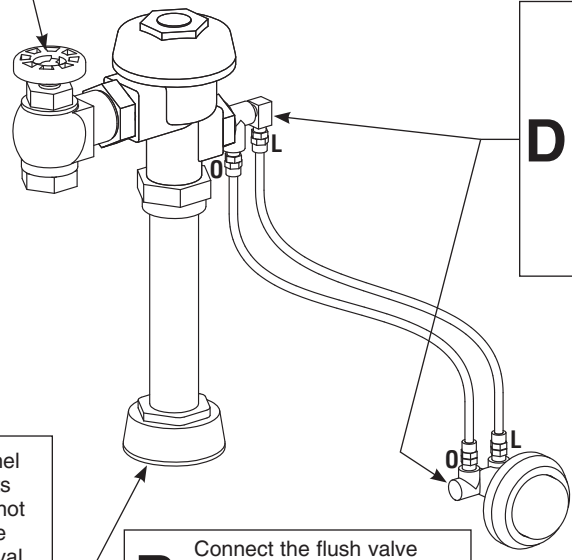

C Connect the flush valve water supply piping to the flush valve 1" NPT inlet.

D Connect the tube from the "O" outlet on the flush valve casting to the "O" indicated on the flush button casting. Connect the tube from the "L" outlet on the flush valve casting to the "L" indicated on the flush button casting.

B Connect the flush valve outlet to the top spud inlet of the water closet per manufacturer's instructions.

4 Backflow Preventer and Bedpan Washer

For more details, please reference the rough-in submittal for the backflow preventer.

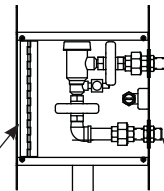

A Connect the piping to the backflow preventer inlet and outlet per local code.

C Connect the backflow preventer outlet pipe to the 1/2" NPT bedpan washer hose.

B Connect the 1/2" NPT volume control valve outlet (or the optional foot valve outlet) to the backflow preventer inlet pipe.
IMPORTANT: The backflow preventer will pipe directly into the hand control inlet. The hand control does not have an outlet.

Bedpan washer cabinet

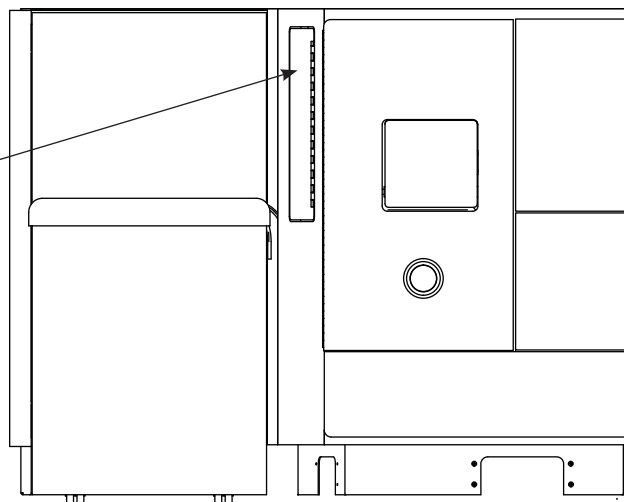

5 **Countertop**

Terreon® top is shown.



A Position the countertop inserts over the brackets on the cabinet and set the countertop in place. Secure the countertop to the cabinet with (3) screws and washers provided.

Optional roll-away shown

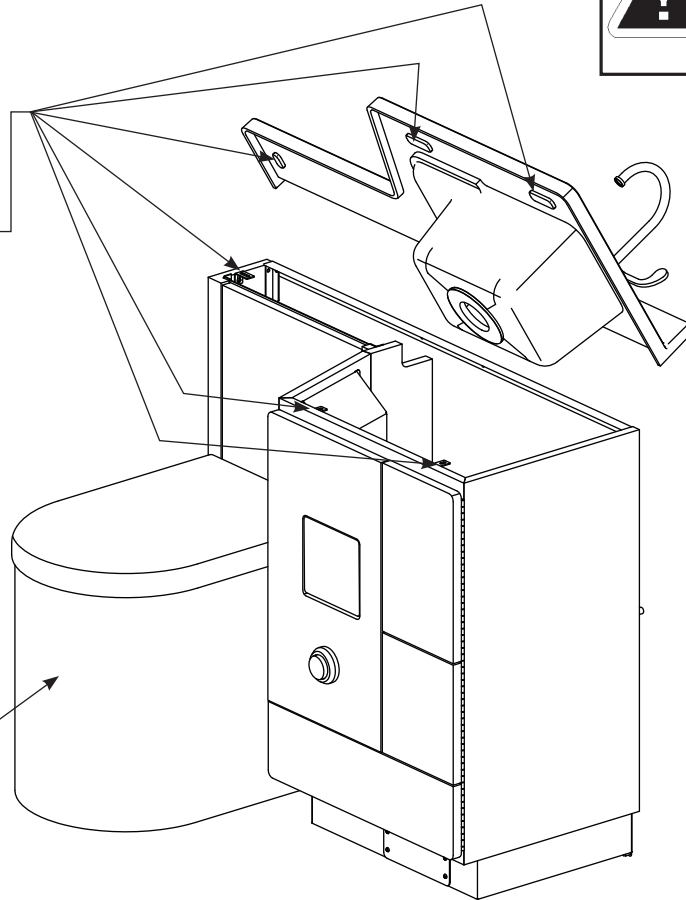

6 **Faucet, Optional Foot Valve and Supplies**

Before connecting supplies, install the faucet per manufacturer's instructions.

B Connect the hot and cold water supply piping to the 1/2" NPT inlet connections on the foot valve.

C Connect the P-trap to the sink's 1-1/4" or 1-1/2" O.D. drain pipe and to the 1-1/2" O.D. tailpiece from the wall.
IMPORTANT: Laminate top option requires 1-1/4" to 1-1/2" adapter for drain connection.

D Turn on the water supplies and check for leaks and adequate water flow. Activate the faucet, bedpan washer and flush valve several times to purge air from the supply lines.

A Connect one end of the supply hose to the supply shank on the faucet.
Connect the other end of the hose to the foot valve outlet connection.

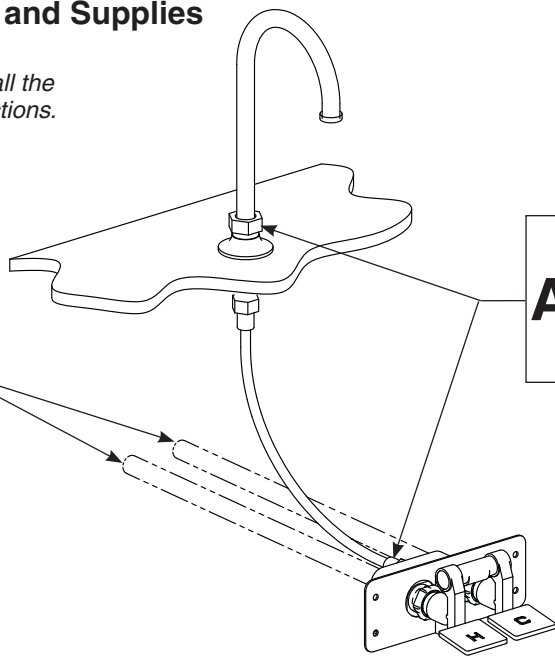

Cleaning and Maintenance for Terreon®

Material Description: Terreon® is an NAHB Certified densified solid surface material composed of polyester resin and is resistant to chemicals, stains, burns and impact. Surface damage can be easily repaired with everyday cleansers or fine grit abrasives.

Routine Cleaning: Clean daily or as often as conditions require using a standard commercial or household cleaner such as Formula 409® or Windex®.

Stubborn Stains: Remove tough stains with Ajax®, Comet®, or Soft-Scrub® and a green Scotch-Brite® pad or lightly sand in a circular motion with 240 grit wet/dry sandpaper. The finish can be renewed with a maroon Scotch-Brite® pad.

Special Situations for Terreon Material

Scratches: Remove scratches with a green Scotch-Brite® pad. The finish can then be renewed with a maroon Scotch-Brite® pad, followed by a white Scotch-Brite® pad or 30-micron sandpaper.

Hard Water Deposits: Remove hard water deposits with a mild solution of vinegar and water. Always rinse the unit thoroughly after cleaning.

Restoring the surface: Use Hope's® Solid Surface cleaner and polish to refresh and protect the Terreon® Solid Surface material. Bradley recommends additional care and maintenance for the darker colored Terreon®, for complete instructions on this additional maintenance refer to Bradley technical document #1505.



Do not use strong acid or alkaline chemicals and cleansers to clean Terreon®. If these chemicals come in contact with the surface, wipe them off immediately and rinse with soapy water. Avoid contact with harsh chemicals such as paint remover, bleach, acetone, etc. Avoid contact with hot pans and objects.

Repair Kits: Terreon® repair kits are available. Contact your Bradley representative or distributor for part numbers and pricing. Repair kits are made to order and have a shelf life of 30 days.



Terreon® is a unique, cast solid surface material. Aggregate flow and distribution as well as shades of color can vary from product to product creating natural characteristics.

Cleaning Stainless Steel

Material Description: Stainless steel is extremely durable, and maintenance is simple and inexpensive. Proper care, particularly under corrosive conditions, is essential. Always start with the simplest solution and work your way toward the more complicated.

Routine Cleaning: Daily or as often as needed use a solution of warm water and soap, detergent, or ammonia. Apply the cleaning solution per the manufactures instructions and always use a soft cloth or sponge to avoid damaging the finish.

Stubborn Stains: To remove stains from stainless steel use a stainless steel cleaner and polish such as Ball® stainless steel cleaner or a soft abrasive. Always follow the manufactures instructions and apply in the same direction as the polish lines.



Never use ordinary steel wool or steel brushes on stainless steel. Always use stainless steel wool or stainless steel brushes.

Special Situations for Stainless Steel Material

Fingerprints and Smears: To remove fingerprints or smears use a high quality stainless steel cleaner and polish in accordance with the manufactures instructions. Many of these products leave a protective coating the helps prevent future smears and fingerprints.

Grease and Oil: Grease and Oil : To remove grease and oil use a quality commercial detergent or caustic cleaner. Apply in accordance to the manufactures instructions and in the direction of the polish lines.

Precautions: Precautions: Avoid prolonged contact with chlorides (bleaches, salts), bromides (sanitizing agents), thiocyanates (pesticides, photography chemicals, and some foods), and iodides on stainless steel equipment, especially if acid conditions exist.



Do not permit salty solutions to evaporate and dry on stainless steel.

The appearance of rust streaks on stainless steel leads to the belief that the stainless steel is rusting. Look for the actual source of the rust in some iron or steel particles which may be touching, but not actually a part of the stainless steel structure.



Strongly acidic or caustic cleaners may attack the steel causing a reddish film to appear. The use of these cleaners should be avoided.

Brand Names

Use of brand names is intended only to indicate a type of cleaner. This does not constitute an endorsement, nor does the omission of any brand name cleaner imply inadequacy. Many products named are regional in distribution, and can be found in local supermarkets, department and hardware stores, or through your cleaning service. It is emphasized that all products should be used in strict accordance with package instructions.