

Installation and Maintenance Instructions

Bradley Stainless Steel Lavatory Model Nos. 921-6380 & 921-6580

Table of Contents

Installation Instructions	2-3
Cleaning Stainless Steel	4
warranty	

IMPORTANT

Read this entire instruction sheet to ensure proper installation.

Make sure that water supply is completely off before installation is begun.

Flush all the water supply lines before making connections.

File these instructions with the owner or maintenance department.

Compliance and conformity to local codes and ordinances is the responsibility of the installer.



Installation Instructions continued. ..

Step 2: Installation

1. Assemble four 1/2-13 threaded studs into back of fixture by screwing in approximately 1/2".
2. Assemble the wall drain pipe to the drain coupling located on the back of the fixture.
3. Secure fixture to wall using nuts, washers and brackets provided. Fasteners must be securely tightened to 60 ft. lbs.

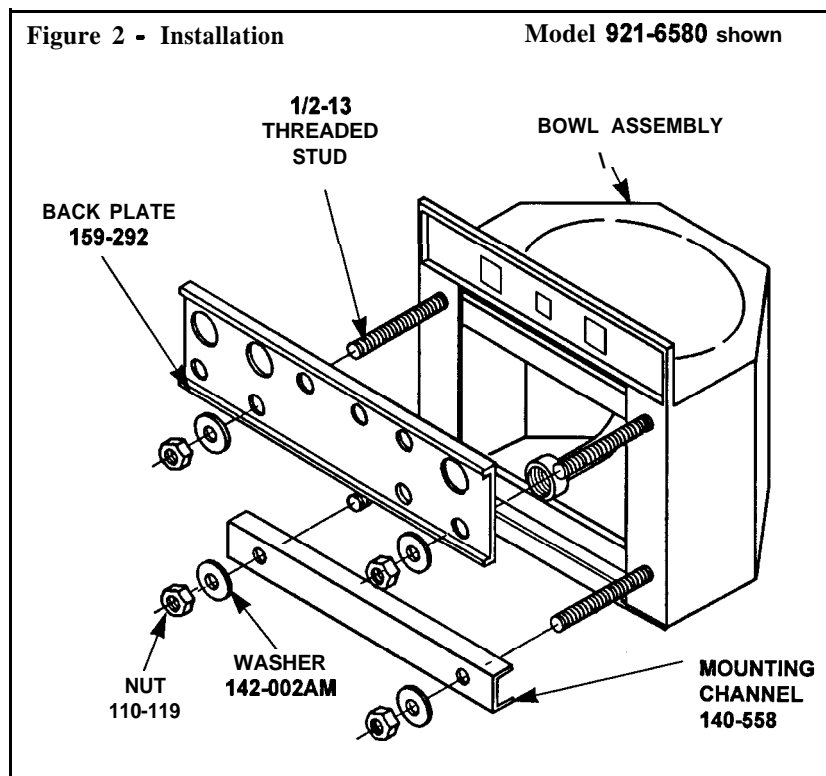

Cleaning Stainless Steel

Frequent cleaning can prolong the service life of the stainless steel components, as well as maintain an attractive appearance. Adhere to the following cleaning suggestions:

- Stainless steel should be rinsed and dried thoroughly after washing. Ordinary deposits of dirt and grease can be removed with soap and water. For stubborn deposits, use a stainless steel polishing powder.
- DO NOT allow salt solutions to evaporate on stainless steel.

⚠ IMPORTANT: DO NOT USE STEEL WOOL OR STEEL BRUSHES TO CLEAN STAINLESS STEEL. PARTICLES OF STEEL CAN BECOME LODGED IN THE STAINLESS STEEL AND EVENTUALLY RUST.

- The appearance of rust on stainless steel is not an indication that the stainless steel is rusting, rather, it is the result of rusting deposits of iron or ordinary steel lodged in the stainless steel. If necessary, use only stainless steel brushes or stainless steel wool.
- Avoid the use of acidic or caustic cleaners, as they can corrode stainless steel causing a reddish film to appear.

Lavatory Warranty

Bradley Corporation warrants to commercial and institutional purchasers only each unit free from defects in material and workmanship under normal use and service upon the following terms and conditions.

1. This warranty is limited to replacing or repairing, at our option, transportation charges prepaid by the purchaser, any Bradley unit or part thereof which our inspection shall show to have been defective within the limitations of this warranty.
2. The period during which Bradley's urinal is warranted is measured one (1) year from the date of our invoice.
3. This warranty does not cover installation or any other labor charges and does not apply to any units which have been damaged by accident, abuse, improper installation or improper maintenance.
4. The replacement or repair of defective units as stated in this warranty shall constitute the sole remedy of the purchaser and the sole liability of Bradley Corporation under this warranty. Bradley Corporation shall not otherwise be liable under any indirect damages caused by defects in the repair or replacement thereof.
5. This warranty extends only to commercial and institutional purchaser and does not extend to any others, including consumer customers of commercial institutional purchasers.
6. This warranty is in lieu of all other warranties, expressed or implied, including any implied warranty of merchantability or fitness for a particular purpose or otherwise.