

Model 923-8300

# Installation

## Stainless Steel Saddle-Type Washout Urinal

### Models:

923-8300

923-8301

923-8302FM

923-8303FM

### Table of Contents

Overview .....	2
Pre-Installation Information .....	3
Installation Instructions .....	4-7
Cleaning Instructions .....	7
Flush Valve Troubleshooting.....	8



## WARNING



Read this entire installation manual to ensure proper installation. When finished with the installation, file this manual with the owner or maintenance department. Compliance and conformity to local codes and ordinances is the responsibility of the installer.



Separate parts from packaging and make sure all parts are accounted for before discarding any packaging material. If any parts are missing, do not begin installation until you obtain the missing parts.



Before installing components, all connection supply lines must be flushed and free of foreign material such as pipe dope, chips, solder, etc. Bradley will not be responsible for leaking valves due to the presence of foreign material, or distorted stop gaskets where excessive pressure (above 30 lbs. of torque) has been applied to the stop cap.

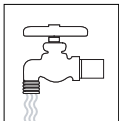

After flushing has been completed, make sure that all water supply lines have been completely turned off before beginning installation. After installation has been completed, turn the water supply lines back on and test the unit for leaks and adequate water flow.



Product warranties may be found under "Product Information" on our web site at [www.bradleycorp.com](http://www.bradleycorp.com).

# Overview

## Construction

**Materials:** All cabinet materials, including interior, are Type 304 stainless steel. The cabinet, bowl, flushing rim, trap and trap covers are 14 gauge stainless steel. The P-Trap waste is 16-gauge.

**Finish:** All exposed stainless steel surfaces are polished to a #4 satin finish. Exposed fittings are triple chrome plated.

**Wall Anchoring:** Standard fixture is completely secured from pipe chase side with rustproof mounting hardware so there are no exposed mounting fasteners in cell area. FM (front mounted) units have rustproof mounting hardware.

## Accessories

Whenever chase access is not possible for a built-in flush valve, Bradley recommends a 7900 series flush valve box. This unit can be used with back-supplied Bradley toilets and urinals.

## Supplies required:

- 1" NPT supply piping to flush valve or 3/4" pending flush valve type.
- Urinal waste connections.
- Wire nuts sized for 22 AWG wire to connect to 24 VAC power source (for TouchTime).

## Urinal Warranty Information

Bradley Corporation warrants to commercial and institutional purchasers only each unit free from defects in material and workmanship under normal use and service upon the following terms and conditions.

1. This warranty is limited to replacing or repairing, at our option, transportation charges prepaid by the purchaser, any Bradley unit or part thereof which our inspection shall show to have been defective within the limitations of this warranty.
2. The period during which Bradley's urinal is warranted is measured one (1) year from the date of our invoice.
3. This warranty does not cover installation or any other labor charges and does not apply to any units which have been damaged by accident, abuse, improper installation or improper maintenance.
4. The replacement or repair of defective units as stated in this warranty shall constitute the sole remedy of the purchaser and the sole liability of Bradley Corporation under this warranty. Bradley Corporation shall not otherwise be liable under any indirect damages caused by defects in the repair or replacement thereof.
5. This warranty extends only to commercial and institutional purchaser and does not extend to any others, including consumer customers of commercial institutional purchasers.
6. This warranty is in lieu of all other warranties, expressed or implied, including any implied warranty of merchants ability or fitness for a particular purpose or otherwise.

# Pre-Installation Information

## ⚠ IMPORTANT

- Read this entire instruction sheet to ensure proper installation.
- Make sure that water supply is completely off before installation is begun.
- Flush all the water supply lines before making connections.
- Wall anchors used must have a minimum pull-out rating of 1,000 lbs.
- File these instructions with the owner or maintenance department.

## Urinal Dimensions

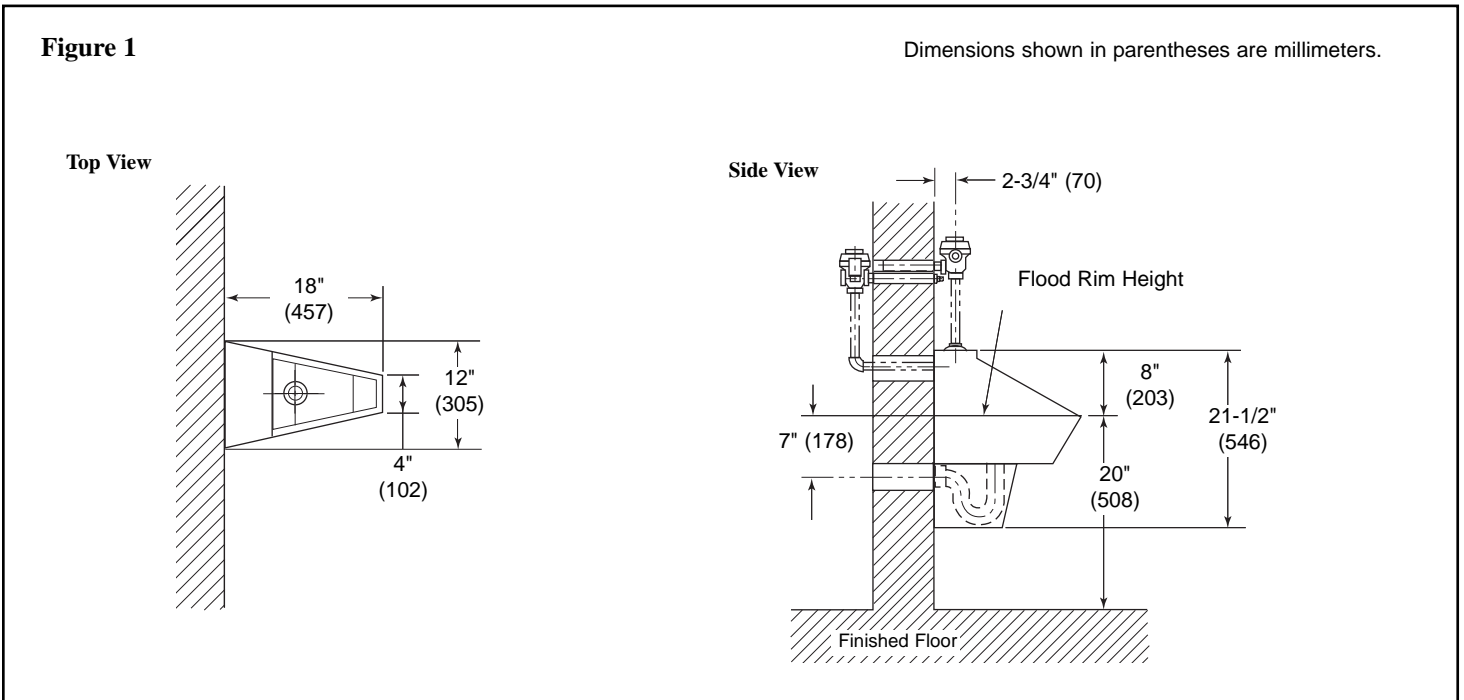

# Installation Instructions

## Step 1: Rough-in supplies, drain and waste outlet

### ▲ IMPORTANT:

- Compliance and conformity to local codes and ordinances is the responsibility of the installer
- Make sure that the water is completely shut off before beginning installation
- Wall anchors need to withstand 1000 lb. pull force.

NOTE: See Figures 2 & 3 for piping rough-in dimensions and wall anchor locations.

1. Rough-in wall opening for a unit as shown.
2. Rough-in a 1" NPT supply inlet to flush valve or 3/4" pending flush valve type.
3. Rough-in a waste outlet at the dimension shown.

**Figure 2 - Chase-Mounted Fixtures**

Dimensions shown in parentheses are millimeters.

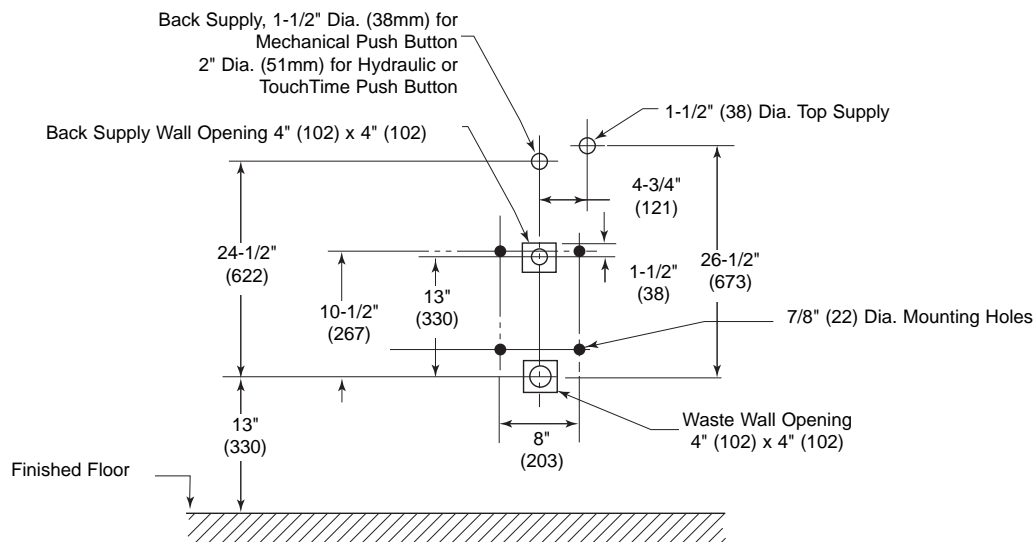

**Figure 3 - Front-Mounted (FM) Fixtures**

Dimensions shown in parentheses are millimeters.

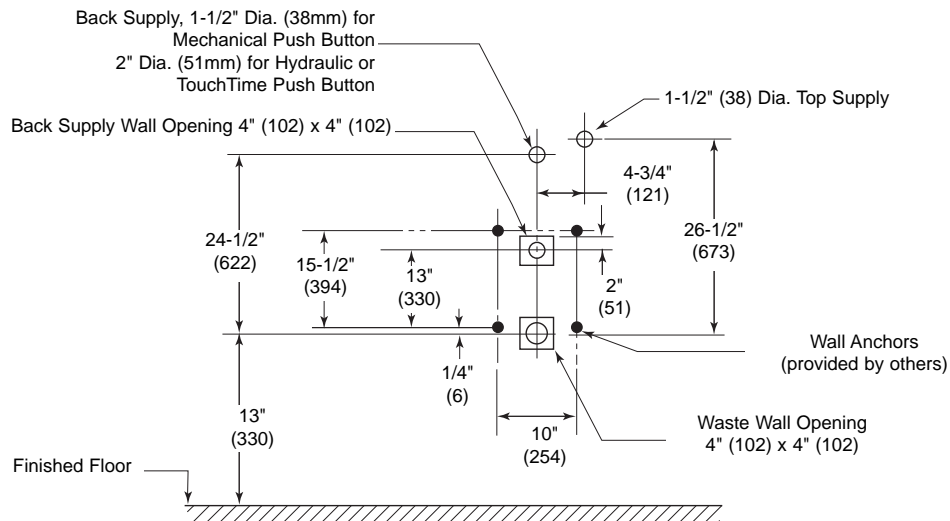

## Step 2a: Mount unit to wall

### FOR CHASE-MOUNTED FIXTURES (SEE INSTRUCTIONS ON PAGE 6 FOR FRONT-MOUNTED UNITS)

NOTE: Refer to Figure 4 when mounting unit.

1. Install 1/2-13 threaded studs approximately 1/2" into back of fixture.
2. Assemble 3/4" flush valve supply pipe (furnished by others) to 3/4" NPT inlet half coupling located on back of fixture.
3. Sliding studs and pipes through wall openings, locate fixture in place (flood rim height at 20" above finished floor).
4. Secure fixture to wall using anchor brackets, washers and nuts provided.

**⚠ CAUTION: All fasteners must be securely tightened to approximately 60 ft./lbs.**

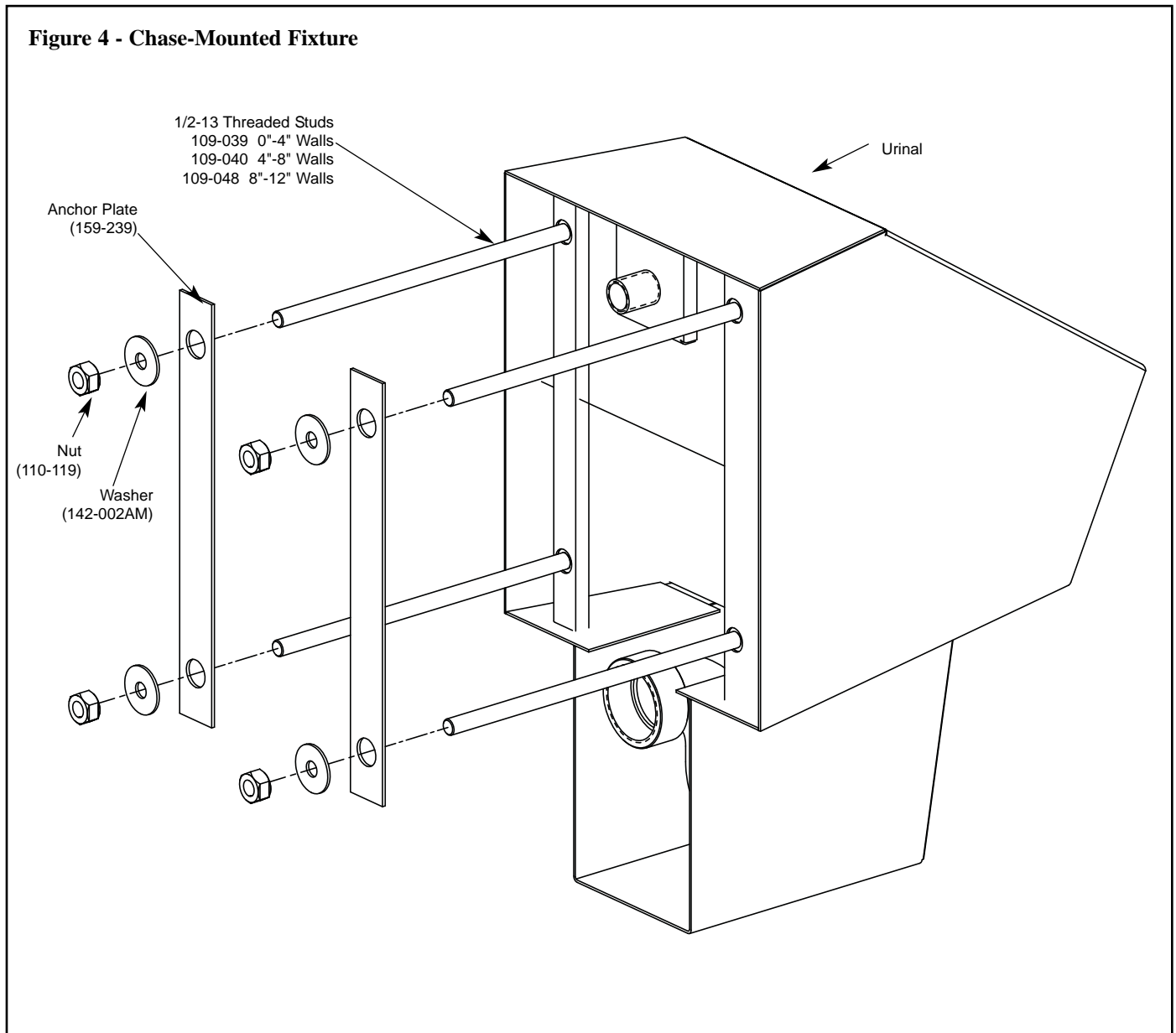

## Step 2b: Mount unit to wall

### FOR FRONT-MOUNTED (FM) FIXTURES (SEE INSTRUCTIONS ON PAGE 5 FOR CHASE-MOUNTED UNITS)

*NOTE: Refer to Figure 5 when mounting unit.*

1. Select location on wall where fixture is to be installed. Strike vertical centerline of fixture on wall using a plumb-bob. Draw centerline approximately 50" long starting at finished floor. Strike appropriate horizontal lines for required wall openings and wall anchors as shown.

*NOTE: Use extreme care when making wall openings. Only 1/8" adjustment is provided between the 3/8" diameter fixture mounting holes and the 1/4"-20 screws provided with the fixture.*

2. Install wall anchors. Remove test cap from slip joint waste connector and install on the drain line per dimensions shown. Lubricate O-ring on the connector and slide urinal into place using care not cut the O-ring. Check for proper alignment of wall anchors with fixture mounting holes. (Flood rim height at 20" above finished floor.)
3. Remove the urinal from the wall. Install the test cap on the slip joint waste connector until system check is complete.
4. Remove the test cap and reinstall urinal to the wall. Secure with vandal-proof screws and finishing washers provided.

**⚠ CAUTION: All fasteners must be securely tightened to approximately 60 ft./lbs.**

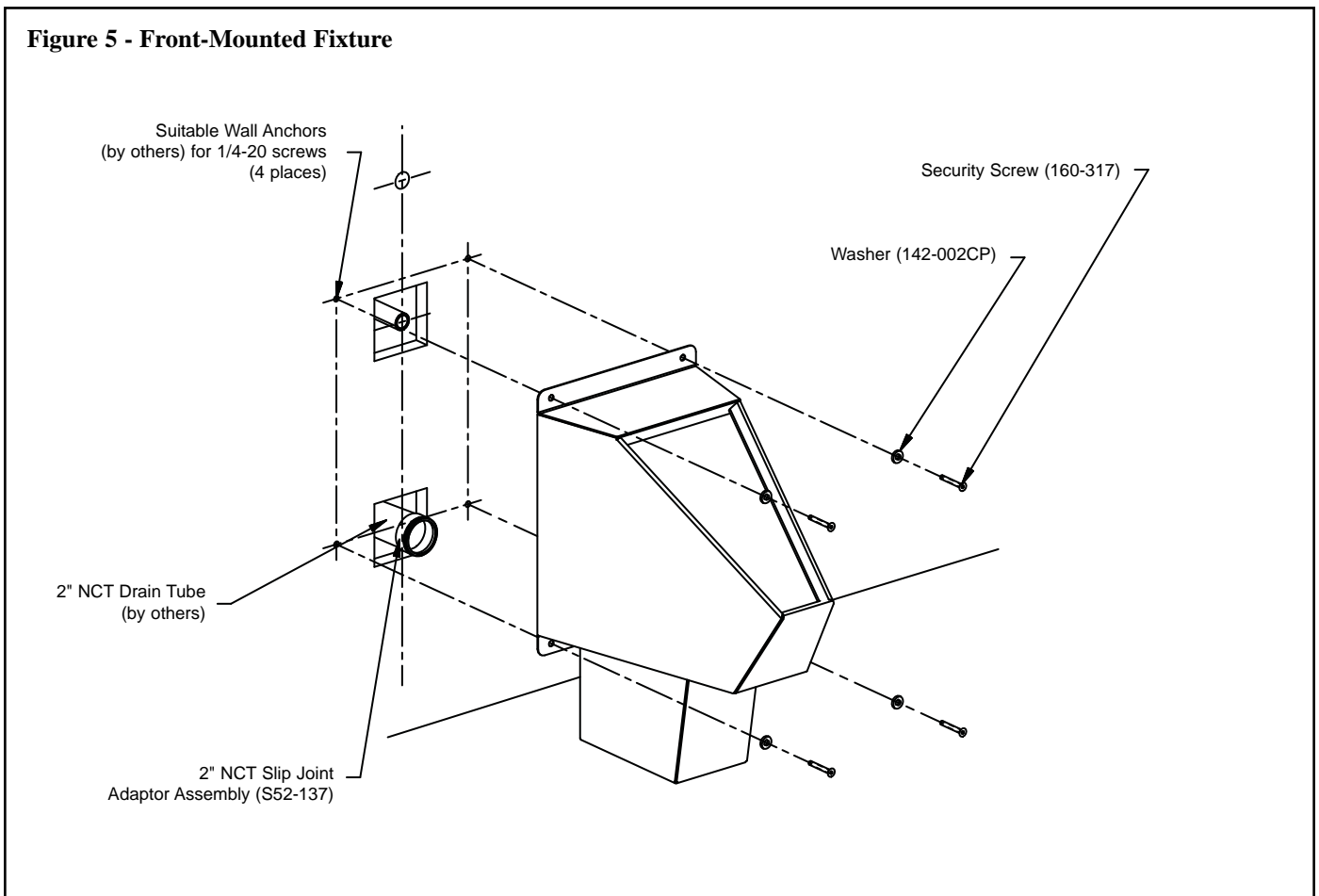

### Step 3: Make supply, drain and waste connections

**⚠ IMPORTANT: Flush all supply lines thoroughly before making connections.**

1. Make water supply connections to flush valve (piping supplied by installer).
2. Make the waste outlet connections (piping supplied by installer).
3. Install the flush valve assembly in the appropriate location. Refer to the Installation Instructions supplied with the valve for assembly procedure.

*NOTE: On units equipped for top water supply, flush valve is mounted last, after fixture is fully mounted on the wall.*

### Step 4: Complete installation

1. Turn on water supply to the unit and check for leaking.
2. Activate the flush valve several times to purge air from lines.

## Cleaning Instructions

Stainless steel is extremely durable, and maintenance is simple and inexpensive. Proper care, particularly under corrosive conditions, is essential. Follow the cleaning instructions listed below.

- Ordinary deposits of dirt and grease are quickly removed with soap and water. Thoroughly rinse and dry the panel after washing. To remove stubborn deposits, use stainless steel polishing powder. In all cases, rubbing should be in the direction of polishing lines.
- Avoid prolonged contact with chlorides, bromides, thiocyanates and iodides on stainless steel equipment, especially if acid conditions exist.
- Do not permit salty solutions to evaporate and dry on stainless steel.
- The appearance of rust on stainless steel is not an indication that the stainless steel is rusting. It is the result of rusting deposits of iron or ordinary steel lodged in the stainless steel. If necessary, use only stainless steel brushes or stainless steel wool.

*NOTE: Strongly acidic or caustic cleaners may attack the steel causing a reddish film to appear. The use of these cleaners should be avoided.*

**⚠ IMPORTANT: Do not use steel wool or steel brushes to clean the stainless steel panel. Particles of steel can become lodged in the stainless steel and eventually rust.**

## Flush Valve Troubleshooting

**Problem:** Valve does not function.

Cause: Control stop or main valve is closed.

Solution: Open control stop or main valve.

**Problem:** Insufficient volume of water to adequately siphon fixture.

Cause: Control stop is not open enough.

Solution: Adjust control stop for desired delivery of water.

Cause: Urinal Valve parts installed in Closet Valve.

Solution: Replace inside urinal valve parts with proper valve parts.

Cause: Inadequate volume or pressure at supply.

Solution: If no gauges are available to properly measure supply pressure or volume of water at the valve, then completely remove the entire Diaphragm Assembly and open the control stop to allow water to pass through the empty valve. If the supply is adequate to siphon the fixture in this manner, the Restriction Ring (A-32 on brass guides, A-164 on Cylolac guides) may be removed from the bottom of the guide to provide additional flow or a Sloan Guide Assembly (A-13-A Fullback) may be installed in the valve. Should neither of these steps work, increase the pressure and/or supply.

**Problem:** Valve closes off immediately.

Cause: Ruptured or damaged diaphragm.  
Enlarged by-pass orifice from corrosion or damage.

Solution: Install inside parts kit to correct problem and update the flush valve.

**Problem:** Length of flush too short (short flushing).

Cause: Diaphragm assembly and guide assembly are not hand tight.

Solution: Screw the two assemblies hand tight.

Cause: Enlarged by-pass orifice from corrosion or damage.

Solution: Install inside parts kit to correct problem and update flush valve.

Cause: A-19-AU Urinal Relief Valve installed in Closet Flush Valve.

Solution: Replace the Urinal Relief Valve with HY-34-A Closet Relief Valve.

**Problem:** Length of flush too long (long flushing) or failing to close off.

Cause: Relief Valve (HY-34-A) is not seating properly or by-pass orifice is clogged because of foreign material, or by-pass orifice is closed by an invisible gelatinous film from "over-treated" water.

Solution: Disassemble the working parts and wash them thoroughly.

*NOTE: The size of the orifice in the by-pass is very important for the proper metering of water into the upper chamber of the valve. DO NOT enlarge or damage this orifice.*

Cause: Line pressure has dropped and is not sufficient to force Relief Valve to seat.

Solution: Shut off control stops until pressure has been restored, then open them again.

**Problem:** Water splashes out of fixture.

Cause: Supply volume is more than necessary.

Solution: Throttle down control stop.

Cause: Lime accumulation on vortex or spreader holes.

Solution: Remove lime build-up.