

- Ideal for renovations
- Large 2-1/4" diameter stainless steel drain pipe
- Reinforced receptor pan
- All units factory tested for proper operation

Specifications

Materials

All cabinet materials are Type 304 stainless steel. The fixture is made from heavy gauge stainless steel with seamless welded surfaces.

Construction

Panel

Panels are pierced and tapped to use #10-24 vandal-resistant screws for assembling unit together. Shower receptor pan is welded solid with exposed welds ground smooth to eliminate all accessible seams and voids. Underside of receptor is reinforced with heavy stainless steel center support to floor. Drain has over 2 square inches of free area. Waste pipe connections are anchored to prevent damage. Vent grille is 6-1/2" x7-1/2" square, has 1/4" round holes and over 20 square inches of free area. Cabinet is shipped completely assembled with valve shipped loose for field installation.

Bradley's "SX" severe service showerhead is installed on column. Stainless steel soap dish has concealed fasteners. Tension-release towel hook is secured on outside of entry. Elbow waste and P-trap are sloped 1/4" per foot and factory-piped to chase wall with 2-1/4" no-hub connection. 2" caulk style waste also available.

Valves

Two valve arrangements are offered on unit. Both valve types are chase located:

- Single Temperature Air Metering Valve with 5 to 60 second timing cycle adjustable from chase side only.
- TouchTime® equipped fixtures control water flow at each station through the use of solid state, digital circuitry. When the push button is pressed, a signal is sent through its built-in circuitry controlling the opening and closing of solenoid valves. The system operates directly on 24 volt power or 110 volt with the use of an optional transformer. Timing is electronically controlled at 60 seconds.

Showerhead

Bradley "SX" severe service 2.5 GPM showerhead has fixed direction spray. Spray pattern is adjusted through orifice with 1/8" Allen wrench.

Finish

Exposed sides at the exterior and interior, except receptor, have a #4 satin finish. Receptor has a non-skid surface. Exposed fitting surfaces are triple chrome plated.

Wall Anchoring

Wall or floor anchors are not provided as standard equipment. Unless optional anchors are specified, the cabinet is free-standing. Anchors are recommended for locations where extreme abuse is likely.



Fixture requires wall openings and accessible chase for installation and maintenance. Some field assembly may be required.

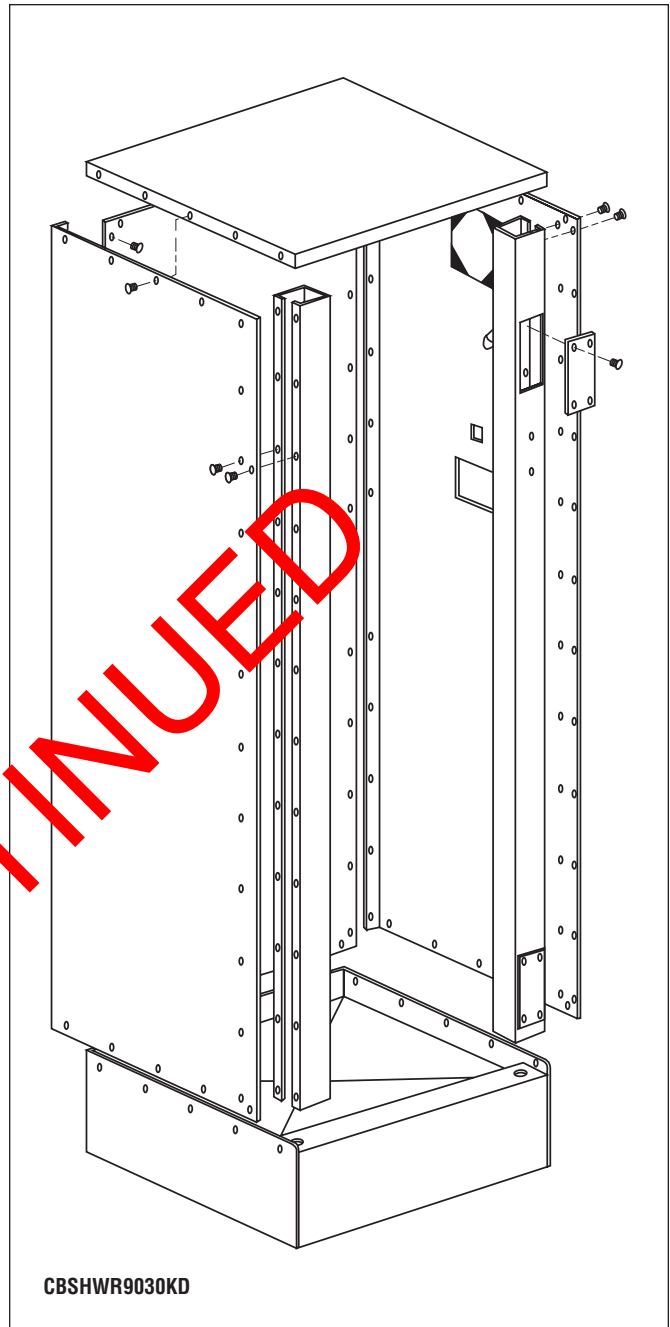

Model	Size (Must select one)
<input type="checkbox"/> 9030KD	30" x 30"
<input type="checkbox"/> 9032KD	32" x 32"
<input type="checkbox"/> 9036KD	36" x 36"

Required Selections (Must select one from each category)

Drain (select one):

- EW-NH** Elbow Waste No Hub Drain
- PT-NH** P-Trap No Hub Drain
- CAK** Caulk Drain

Chase Location (select one):

- RIGHT** Right Side
- BACK-R** Back Chase, Right*
- LEFT** Left Side
- BACK-L** Back Chase, Left*

Polish (select one):

- | | |
|---|---|
| <input type="checkbox"/> RP Right Side | <input type="checkbox"/> LP Left Side |
| <input type="checkbox"/> BP Both Sides | <input type="checkbox"/> NP No Polish on Sides |

Valve Assembly (select one):

- ASTM** Air Single Temp Metering Valve
- TTST** TouchTime® Single Temp Electronic Metering Valve
- NV** No Valve

Optional Selections

Valve Boxes:

- RMPB** Recessed Mounted Pressure Balancing Box
- SMPB** Surface Mounted Pressure Balancing Box

Other Options:

- DOOR** Stainless Steel Door

* Back Chase Location, showerhead on right or left as indicated



Top and chase side exterior are not polished.

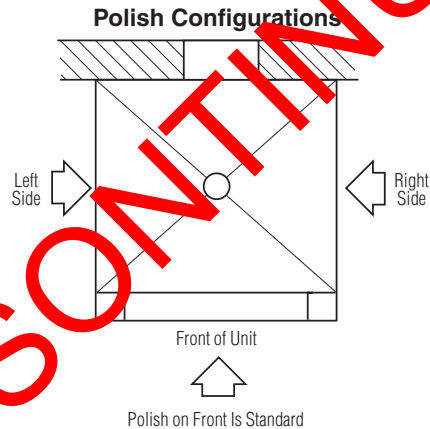

Chase configurations are provided to show relationship of drain and showerhead locations to the chase wall. Vent grille, push button, and recessed soap dish are located on the shower panel positioned against the chase wall.

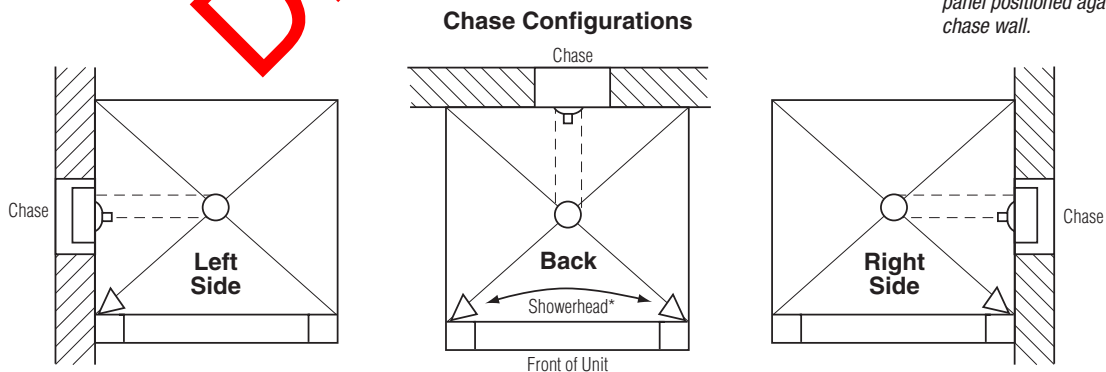

(mm)

Descriptive Notes:

1. Integral strainer has over two square inches of free area.
2. Showerhead spray is directed into cabinet corner.
3. Tension-release towel hook is installed on the same side as showerhead.
4. Vent grille has 1/4" round holes with over 20 square inches of free area.
5. Recessed soap dish.
6. Elbow waste shown. Dotted line indicates P-trap waste (2-1/4" stainless steel tubing).
7. Center support integral with receptor reinforcement.
8. Optional Lead Caulk waste.

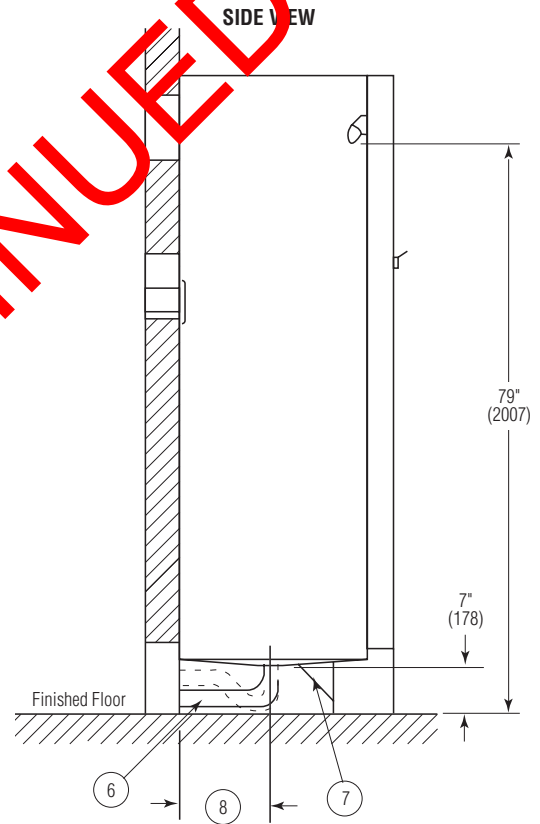
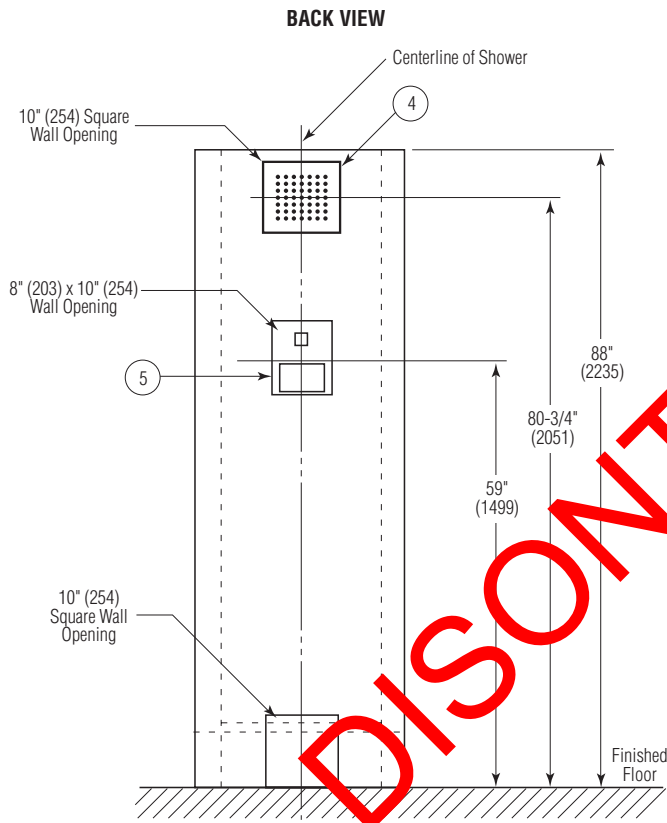
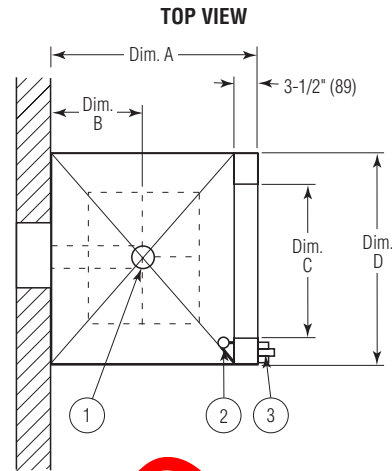

DISCONTINUED



See installation instruction for drain configurations and dimensions.

MODELS

Size Code	Dimension A	Dimension B	Dimension C	Dimension D
30	30" (762)	13-1/4" (337)	23" (584)	30" (762)
32	32" (813)	14-1/2" (368)	25" (635)	32" (813)
36	36" (914)	16-1/4" (413)	29" (737)	36" (914)