

# Installation

## CBSHWR9000KD

### Cabinet Shower

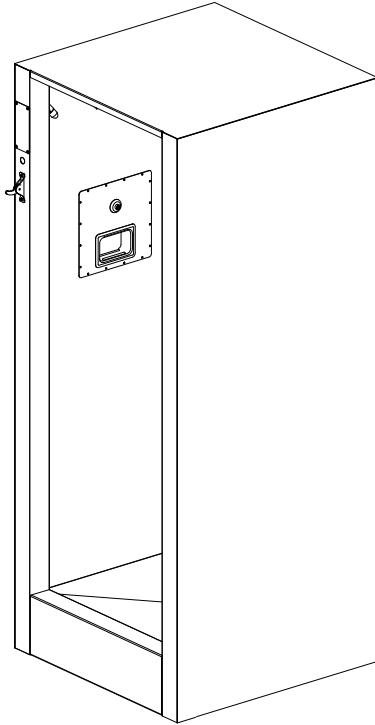

#### Table of Contents

Supplies Required .....	2
Rough-In Information .....	2
Installation Instructions .....	3
Cleaning Instructions .....	4



## IMPORTANT!



**Read this entire installation manual to ensure proper installation. When finished with the installation, file this manual with the owner or maintenance department. Compliance and conformity to local codes and ordinances is the responsibility of the installer. Bradley cannot assume any responsibility for improperly installed units.**



**Separate parts from packaging and make sure all parts are accounted for before discarding packaging material. If any parts are missing, do not begin installation until you obtain the missing parts.**

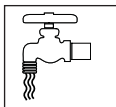

**Make sure that all water supply lines have been flushed and then completely turned off before beginning installation. Debris in supply lines can cause valves to malfunction.**



**Product warranties may be found under "Products" on our web site at [bradleycorp.com](http://bradleycorp.com).**

**Supplies Required:**

- 1/2" NPT supply pipe
- Caulk (suitable for plumbing applications) for panel seams.
- Supplies required for optional lead caulk drain joint.

(mm)

**Floor Drain Rough-In Dimensions**

MODEL	A	B	C
9030KD	30" (762)	15" (381)	13-1/4" (337)
9032KD	32" (813)	16" (406)	14-1/4" (362)
9036KD	36" (914)	18" (457)	16-1/4" (413)

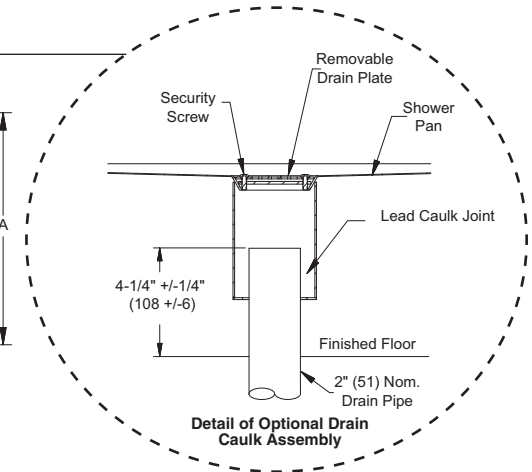
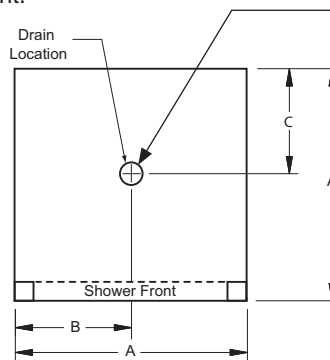

**Configuration and Connection Options**

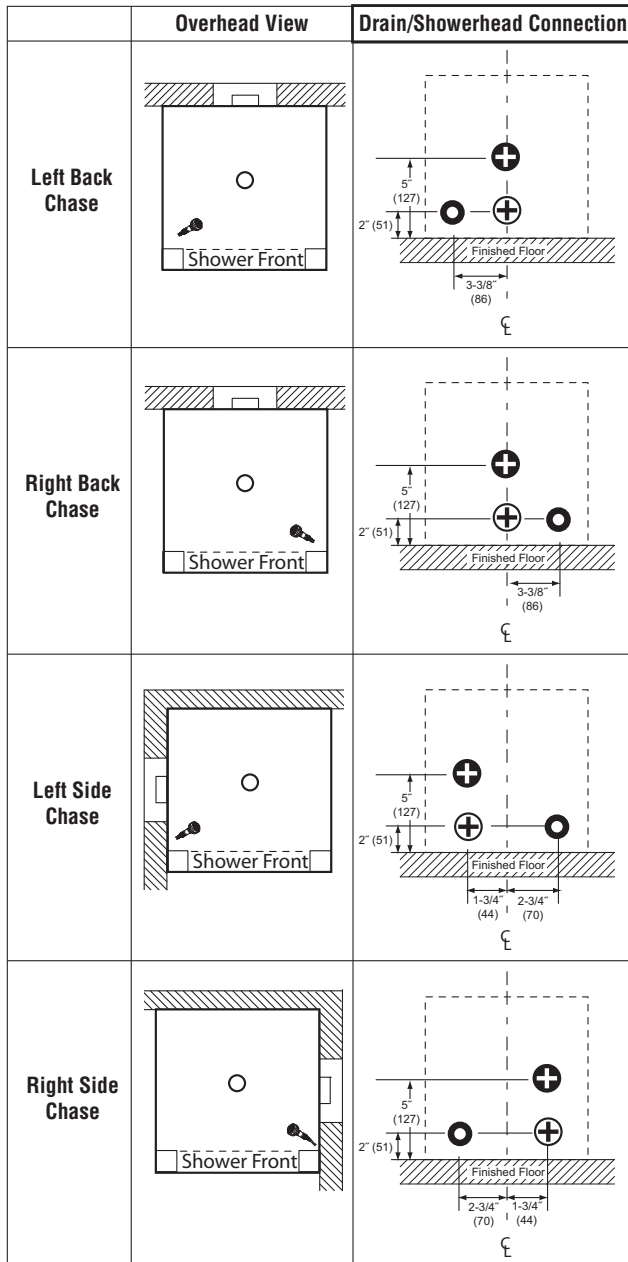

**Rough in Dimensions**

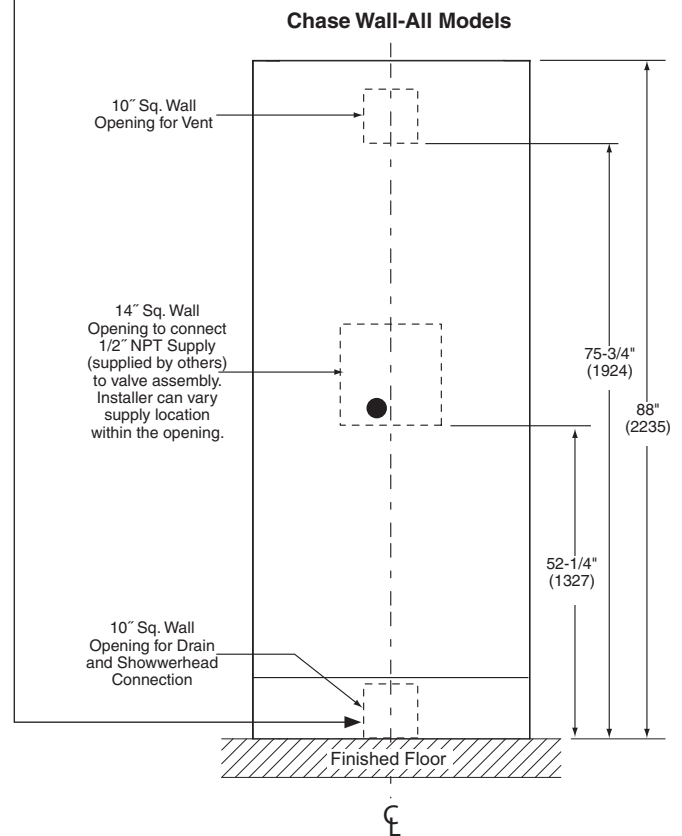

**Key**

- 1/2" Supply: Nominal Copper Tube
- ⊕ 2-1/4" (57) No-Hub P-Trap (if specified)
- ⊕ 2-1/4" (57) No-Hub Elbow (if specified)
- Showerhead Connection Point

# 1 Assemble Shower

**A** For optional caulk drain, position shower pan over drain. Connect drain to lead caulk drain joint. Use no-hub coupling for p-trap and elbow style waste.

**B** Bolt the two side panels and chase panel together. **DO NOT TIGHTEN BOLTS.**

**C** Bolt panels to shower pan. **DO NOT TIGHTEN BOLTS.**

**D** Bolt top to side panels. Tighten all bolts after unit is completely assembled.

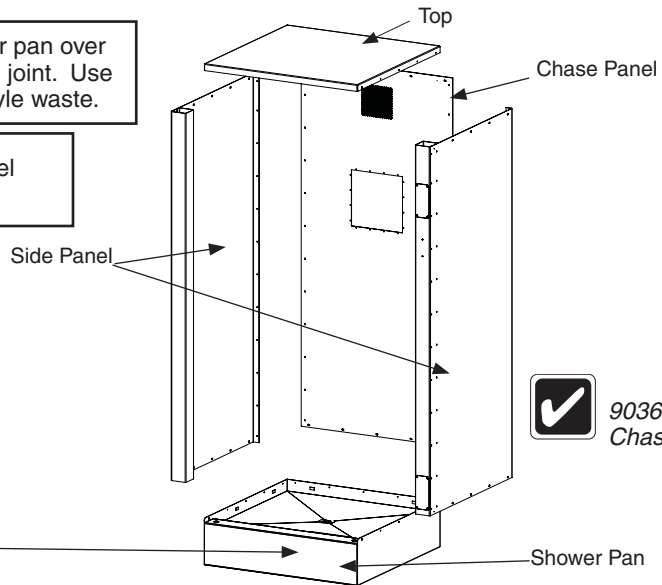

9036KD Back Right Chase Shown.

# 2 Position Shower and Make Plumbing Connections

**A** Install the valve assembly to the supply and attach the push button to the panel per the valve instructions.

**B** Connect 3/8" Showerhead supply tube from the valve assembly to the Showerhead connection point in the base.

**C** Attach Access Panel Assembly to the cabinet with security screws provided.

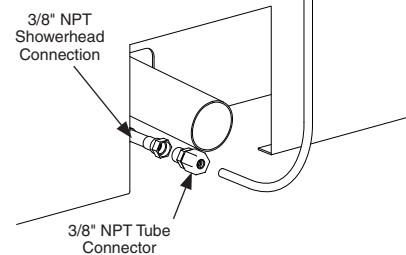
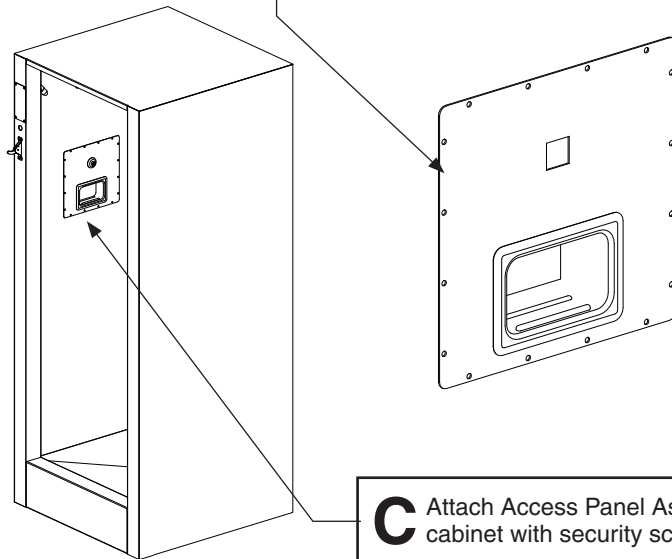

Back View of Chase Panel

9036KD Left Side Chase Shown.

Caulk around Valve Panel to seal against water intrusion.

## Cleaning Stainless Steel

**Material Description:** Stainless steel is extremely durable, and maintenance is simple and inexpensive. Proper care, particularly under corrosive conditions, is essential. Always start with the simplest solution and work your way toward the more complicated.

**Routine Cleaning:** Daily or as often as needed use a solution of warm water and soap, detergent, or ammonia. Apply the cleaning solution per the manufactures instructions and always use a soft cloth or sponge to avoid damaging the finish.

**Stubborn Stains:** To remove stains from stainless steel use a stainless steel cleaner and polish such as Ball® stainless steel cleaner or a soft abrasive. Always follow the manufactures instructions and apply in the same direction as the polish lines.



**Never use ordinary steel wool or steel brushes on stainless steel. Always use stainless steel wool or stainless steel brushes.**

### Special Situations for Stainless Steel Material

**Fingerprints and Smears:** To remove fingerprints or smears use a high quality stainless steel cleaner and polish in accordance with the manufactures instructions. Many of these products leave a protective coating the helps prevent future smears and fingerprints.

**Grease and Oil:** Grease and Oil : To remove grease and oil use a quality commercial detergent or caustic cleaner. Apply in accordance to the manufactures instructions and in the direction of the polish lines.

**Precautions:** Precautions: Avoid prolonged contact with chlorides (bleaches, salts), bromides (sanitizing agents), thiocyanates (pesticides, photography chemicals, and some foods), and iodides on stainless steel equipment, especially if acid conditions exist.



**Do not permit salty solutions to evaporate and dry on stainless steel.**

The appearance of rust streaks on stainless steel leads to the belief that the stainless steel is rusting. Look for the actual source of the rust in some iron or steel particles which may be touching, but not actually a part of the stainless steel structure.



**Strongly acidic or caustic cleaners may attack the steel causing a reddish film to appear. The use of these cleaners should be avoided.**

### Brand Names

Use of brand names is intended only to indicate a type of cleaner. This does not constitute an endorsement, nor does the omission of any brand name cleaner imply inadequacy. Many products named are regional in distribution, and can be found in local supermarkets, department and hardware stores, or through your cleaning service. It is emphasized that all products should be used in strict accordance with package instructions.