

- Constructed of Terreon® Solid Surface Material
- Choose from satin or textured stainless steel cabinets
- ADA and ANSI Compliant

Specifications

The Advocate Lav System features several accessories that mount either with the lavatory system or as stand-alone items. When used as part of the Advocate Lavatory System, the accessories help to prevent water from dripping off hands and on to the floor, making cleaning and maintenance easier while providing a safer restroom environment.

Construction

Shelf Cover

Constructed of Terreon, a densified solid surface material composed of polyester resin or Terreon®RE, a densified solid surface material composed of a bio-based resin and preconsumer recycled granules. Terreon and TerreonRE are resistant to chemicals, stains, burns and impact. Surface damage can be easily repaired with everyday cleansers or fine grit abrasives. Terreon and TerreonRE are NAHB certified to meet ANSI Z124.3, Z124.6 and ANSI/ICPA SS-1-2001. Terreon and TerreonRE are GREENGUARD® certified as low-emitting materials.

Mounting

The LA-Series includes 16 gauge stainless steel mounting channels, eliminating the need for additional specifications and/or casework to support the fixture. All Advocate Lavatory Systems meet or exceed industry standards for load testing.

Standard Equipment

LA15 Advocate Lavatory System Accessories feature cabinets made from 300 series stainless steel. Heavy gauge stainless steel mounting channels support the accessories whether they are standing alone or used as part of the lavatory system.

Towel Dispenser

The Advocate Towel Dispenser module features a solid surface cover and stainless steel cabinet. towel dispenser installs to heavy gauge stainless steel mounting channels. Install this Towel Dispenser for end-users who may prefer a sturdy over hand dryers. Uses one standard center-pull towel roll up to 4" wide x 9" diameter. For more information on the Advocate Towel Dispenser, visit bradleycorp.com.

Waste Receptacle

Waste Receptacle module features a solid surface cover and stainless steel cabinet. The waste receptacle installs to heavy gauge stainless steel mounting channels. Seven-gallon capacity liner is made from type 1 impact resistant PVC and features a handle for easy removal. For more information on the Terreon Waste Receptacle for the Advocate LA-Series, visit bradleycorp.com.

Storage Cabinet

The Advocate Storage Cabinet module features a solid surface cover and stainless steel cabinet with two stainless steel shelves. The storage cabinet installs to heavy gauge stainless steel mounting channels. Install this storage cabinet for cleaning and maintenance personnel to quickly freshen up the restroom area. Capacity is 2.4 cu. ft. For more information on the Advocate Storage Cabinet, visit bradleycorp.com.

Protected by one or more of the following U.S. Patents: D588,676, D595,521. Other Patents Pending.

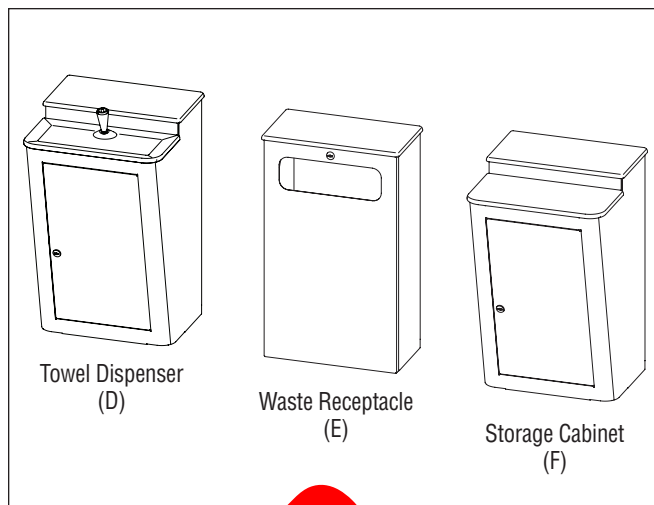

Code Compliance and Certifications

ANSI Standards

Terreon and TerreonRE are certified by NAHB to meet ANSI Z124.3, Z124.6 and ANSI/ICPA SS-1-2001.



Rough-Ins for LA15 Advocate Lavatory System Accessories

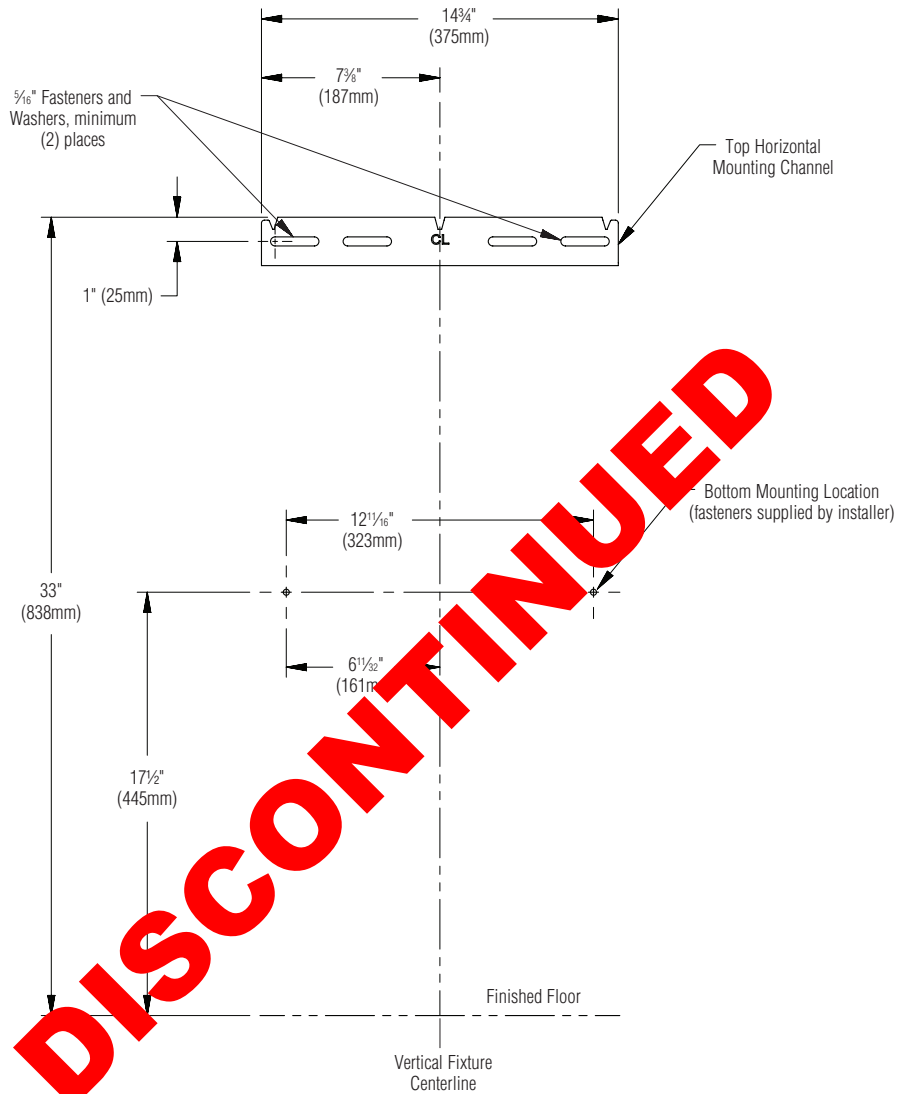

Rough-In Note: Secure the channel to the wall with suitable 5/16" fasteners at either end. Use appropriate backing at these locations. The channel must be horizontal to the floor and positioned with the notches on top of the channel. **DO NOT OVERTIGHTEN.**

Waste Receptacle

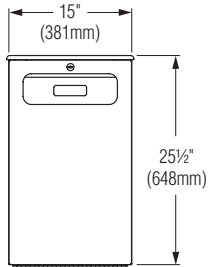

Towel Dispenser

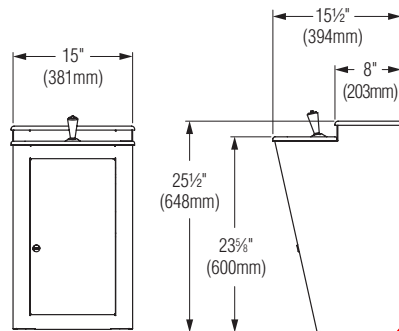

Storage Cabinet

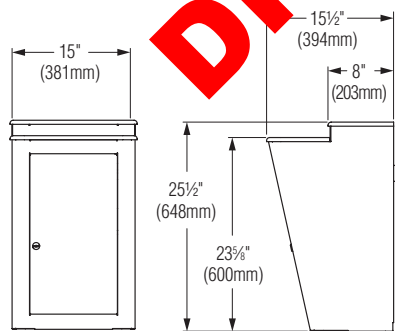

Model

LA15 Advocate Lavatory System – LA-Series

Standard Selections (Must select one from each category)

Color of Terreon Bowl/Dryer Housing/Cover (select one):

Standard Colors

- | | |
|--|---|
| <input type="checkbox"/> E-GRAY Empire Gray | <input type="checkbox"/> GRAPH Graphite |
| <input type="checkbox"/> PEP-WHT Peppered White | <input type="checkbox"/> LANNON Lannonstone |
| <input type="checkbox"/> SAND Sandtrap | <input type="checkbox"/> COBBLE Cobblestone |
| <input type="checkbox"/> CHAR Charcoal Gray | <input type="checkbox"/> WHT SAND White Sand |
| <input type="checkbox"/> JADE Jade | <input type="checkbox"/> LONDON GRAY London Gray |
| <input type="checkbox"/> O-TAUPE Organic Taupe | |

Element Colors

- | | |
|--|---|
| <input type="checkbox"/> SS-GRAY Soapstone Gray | <input type="checkbox"/> CA-TAN Canyon Tan |
|--|---|

*Designer Colors**

- | | |
|--|---|
| <input type="checkbox"/> ARC-CHIP Arctic Chip | <input type="checkbox"/> COFFEE Coffee Bean |
| <input type="checkbox"/> S-SAGE Summer Sage | <input type="checkbox"/> CORN Cornfield |
| <input type="checkbox"/> RIVER Riverstone | <input type="checkbox"/> BLUESKY Blue Sky |
| <input type="checkbox"/> MYSTIC-M Mystic Mist | <input type="checkbox"/> HILLSIDE Hill Side |
| <input type="checkbox"/> STAR-D Star Dust | <input type="checkbox"/> MOUNTAIN Mountain Top |

*TerreonRE Colors**

- | | |
|---|---|
| <input type="checkbox"/> BIRCH-BARK Birch Bark | <input type="checkbox"/> MOONDUST Moondust |
| <input type="checkbox"/> DUSK Dusk | <input type="checkbox"/> OAT Oat |
| <input type="checkbox"/> FERN Fern | <input type="checkbox"/> OCEAN-MIST Ocean Mist |
| <input type="checkbox"/> MAIZE Maize | <input type="checkbox"/> OLIVE Olive |

Cabinet Exposure

- | |
|---|
| <input type="checkbox"/> 1 Stainless Steel, Satin |
| <input type="checkbox"/> 2 Stainless Steel, Textured SWL |

Model # Style

Select the Character for Desired Accessory)

- | |
|--|
| <input type="checkbox"/> D Accessory — Towel Dispenser |
| <input type="checkbox"/> E Accessory — Waste Receptacle |
| <input type="checkbox"/> F Accessory — Storage Cabinet |

* Designer and TerreonRE colors available at an additional charge (non-cancelable, non-returnable).

DISCONTINUED