

# Installation

WF2605

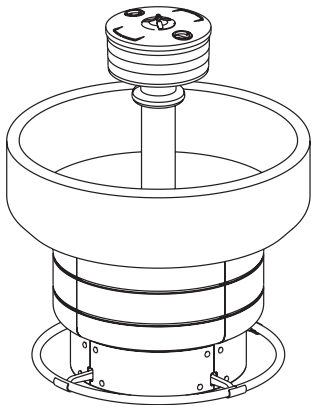

**WF2500 Series Terreon Classic**  
**WF2600 Series Terrazzo**  
**WF2700 Series Stainless Steel**  
**WF2800 Series Bradstone**  
**WF3200 Series Terreon Deep Bowl**  
**TDB3100 Series Terreon Deep Bowl**

WF3203

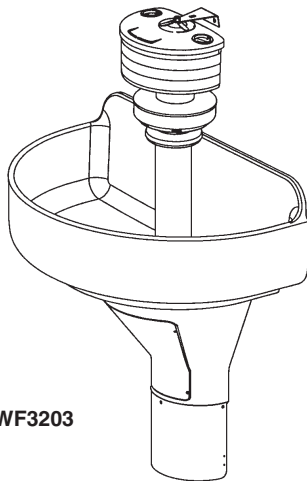

## WARNING

Make sure that all water supply lines have been flushed and then completely turned off before beginning installation. Debris in the supply lines can cause valves to malfunction.

Turn OFF electrical supply to the unit before installation.

## NOTICE

Main water supply to the unit should be "ON" at all times.

## IMPORTANT

Read this installation manual completely to ensure proper installation, then file it with the owner or maintenance department. Compliance and conformity to drain requirements and other local codes and ordinances is the responsibility of the installer.

Separate parts from packaging and make sure all parts are accounted for before discarding any packaging material. If any parts are missing, do not begin installation until you obtain the missing parts.

Product warranties and parts information may also be found under "Products" on our web site at [bradleycorp.com](http://bradleycorp.com).





## Cleaning and Maintenance for Terreon®

**Material Description:** Terreon is a densified solid surface material composed of bio based resin and is resistant to chemicals, stains, burns and impact. Surface can be easily repaired with everyday cleansers or fine grit abrasives. Because Terreon is a unique cast material, its aggregate flow and distribution, and shades of color can vary from product to product creating natural characteristics.

**Routine Cleaning:** For regular cleaning, use mild neutral base cleaners.

**Stubborn Stains:** Remove tough stains with Soft-Scrub® and a green Scotch-Brite® pad or lightly sand in a circular motion with 240 grit wet/dry sandpaper. The finish can then be renewed with a maroon Scotch-Brite pad.

**Scratches:** Remove scratches with a green Scotch-Brite pad. The finish can then be renewed with a maroon Scotch-Brite pad.

**Hard Water Deposits:** Remove hard water deposits with a mild solution of vinegar and water. Always rinse the unit thoroughly after cleaning.

**Restoring the surface:** Use Hope's® Perfect Countertop to refresh and protect the Terreon Solid Surface material. Dark Terreon colors may require additional care and maintenance. For complete instructions on this additional maintenance, visit bradleycorp.com.

**Repair Kits:** Terreon repair kits are available. Contact your Bradley representative or distributor for part numbers and pricing. Repair kits are made to order and have a shelf life of 30 days.

**NOTICE!** Do not use strong acid or alkaline chemicals and cleaners to clean Terreon. If these chemicals come in contact with the surface, wipe them off immediately and rinse with soapy water. Avoid contact with harsh chemicals such as paint remover, bleach, acetone, etc. Avoid contact with hot pans and objects.

## Cleaning and Maintenance for Stainless Steel

**Material Description:** Stainless steel is extremely durable, and maintenance is simple and inexpensive. Proper care, particularly under corrosive conditions, is essential. Always start with the simplest solution and work your way toward the more complicated.

**Routine cleaning:** Daily or as often as needed use a solution of warm water and soap, detergent, or ammonia. Apply the cleaning solution per the manufacturer's instructions and always use a soft cloth or sponge to avoid damaging the finish.

**Stubborn Stains:** To remove stains from stainless steel use a stainless steel cleaner and polish such as Ball® stainless steel cleaner or a soft abrasive. Always follow the manufacturer's instructions and apply in the same direction as the polish lines.

**NOTICE!** Never use ordinary steel wool or steel brushes on stainless steel. Always use stainless steel wool or stainless steel brushes.

**Fingerprints and Smears:** To remove fingerprints or smears use a high quality stainless steel cleaner and polish in accordance with the manufacturer's instructions. Many of these products leave a protective coating that helps prevent future smears and fingerprints.

**Grease and Oil:** To remove grease and oil use a quality commercial detergent or caustic cleaner. Apply in accordance to the manufacturer's instructions and in the direction of the polish lines.

**Precautions:** Avoid prolonged contact with chlorides (bleaches, salts), bromides (sanitizing agents), thiocyanates (pesticides, photography chemicals, and some foods), and iodides on stainless steel equipment, especially if acid conditions exist.

**NOTICE!** Do not permit salty solutions to evaporate and dry on stainless steel.

The appearance of rust streaks on stainless steel leads to the belief that the stainless steel is rusting. Look for the actual source of the rust in some iron or steel particles which may be touching, but not actually a part of the stainless steel structure.

**NOTICE!** Strongly acidic or caustic cleaners may attack the steel causing a reddish film to appear. The use of these cleaners should be avoided.

## Brand Names

Use of brand names is intended only to indicate a type of cleaner. This does not constitute an endorsement, nor does the omission of any brand name cleaner imply inadequacy. Many products named are regional in distribution, and can be found in local supermarkets, department and hardware stores, or through your cleaning service. It is emphasized that all products should be used in strict accordance with package instructions.



## Cleaning and Maintenance for Terrazzo

**Material Description:** Terrazzo is a mosaic-looking natural stone and concrete material polished to a high gloss and sealed with clear polyurethane resin for long lasting beauty. Terrazzo is precast and composed of 85% stone and 15% binder with steel reinforcing rods cast into the bowl.

**Routine Cleaning:** Clean daily or as often as conditions require with any standard detergent, warm water and a soft cloth.

**Stubborn Stains:** If stains have permeated the surface of the terrazzo, follow instructions for restoring the surface listed below.

**Restoring the surface:** Use paint stripper to remove the existing polyurethane (it is important to remove all of the old polyurethane to ensure a high quality finish). Then use light grit sand paper to remove any stubborn stains that have permeated the surface. Clean and thoroughly dry the bowl. Then apply 2 to 3 coats of polyurethane to the terrazzo in accordance with the manufacturer's instructions. Allow the polyurethane to dry completely per the manufacturer's recommendations before turning on the water.

**NOTICE!** If the bowl is not completely dry before applying the polyurethane, the polyurethane will not adhere to the surface.

**NOTICE!** Make sure the surface is completely covered with polyurethane to prevent water from penetrating the surface and damaging the terrazzo.

**Repair Kits:** Terrazzo repair kits are available. Contact your Bradley representative or distributor for part numbers and pricing.

**NOTICE!** Do not place acid or alkaline solutions (floor stripper or drain cleaners) into the terrazzo bowl or use them to clean the bowl. If these solutions come into contact with the terrazzo, rinse the bowl immediately with water and inspect for damage. If damage has occurred, follow the directions for restoring the surface. If bowl begins to haze, it is usually a sign that the terrazzo has come into contact with an acid or alkaline chemical or has been exposed to UV radiation. To repair this condition, follow the instructions for restoring the surface.

## Cleaning and Maintenance for Bradstone

**Material Description:** Bradstone is an extremely durable plastic material made of reinforced thermosetting polyester resins, finely ground inorganic fillers and fade resistant pigments. Bradstone is impervious to most chemicals and stains.

**Routine Cleaning:** Soap and dirt accumulations should be washed off with detergent cleaners. Abrasive and caustic cleaners are not recommended. An occasional waxing with automotive wax will make future cleaning even easier.



*This document describes installation of washfountain bowl and pedestal only. Some optional equipment and accessories are shown for clarity. For activation, optional equipment and accessory installation, see installation documents included with those parts.*



*Before installation of bowl and pedestal assemblies, review all included instructions. Some options may require additional steps during the bowl and pedestal installation process.*

## **Supplies Required by Installer**

- (4) 1/2" lag bolts, screws or other fasteners to anchor washfountain pedestal
- 1/2" nominal copper tubing for hot and cold water supply lines
- 1" hot and cold water or tempered supply lines and fittings (see activation instructions)
- Reducing fittings and 1/2" nominal copper tubing supply lines for types with supplies from above (see activation instructions)
- Standard P-trap (vented trap supplied by Bradley when required)
- 2" drain lines and fittings
- 1-1/2" vent or tie pipe on fixtures vented through washfountain column
- Teflon tape or pipe dope





## Semi-Circular Washfountain Dimensions

### Model WF3204

#### 54" Semi-circular - side view

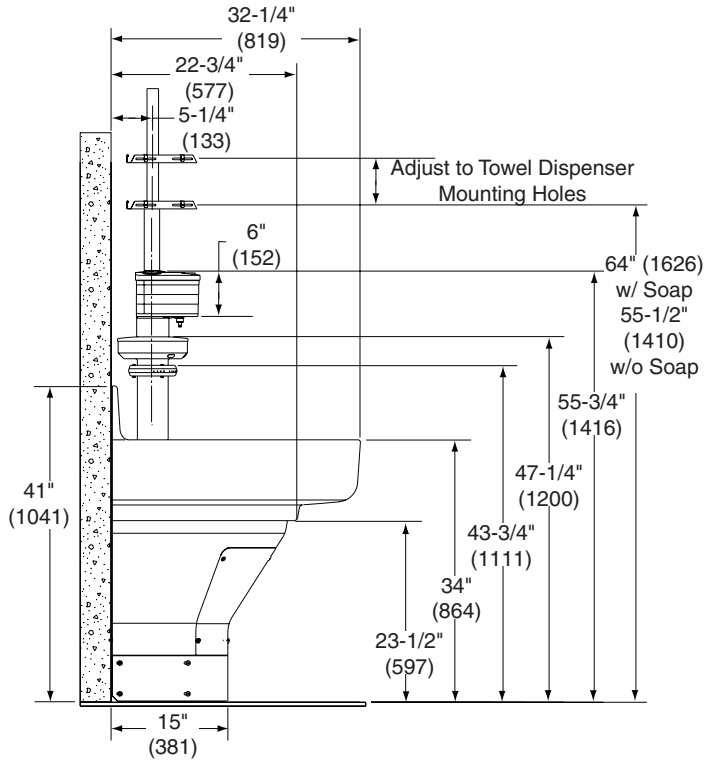

**Model WF3204 is not ADA compliant**



# Rough-In Specifications

(mm)

## Type A Drain

- Supplies from below or through wall
- Vent from below or through wall off-drain

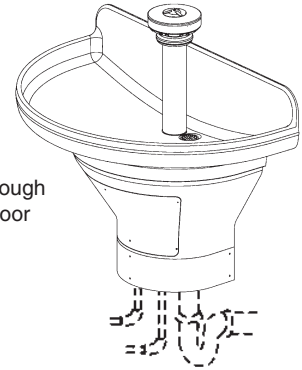
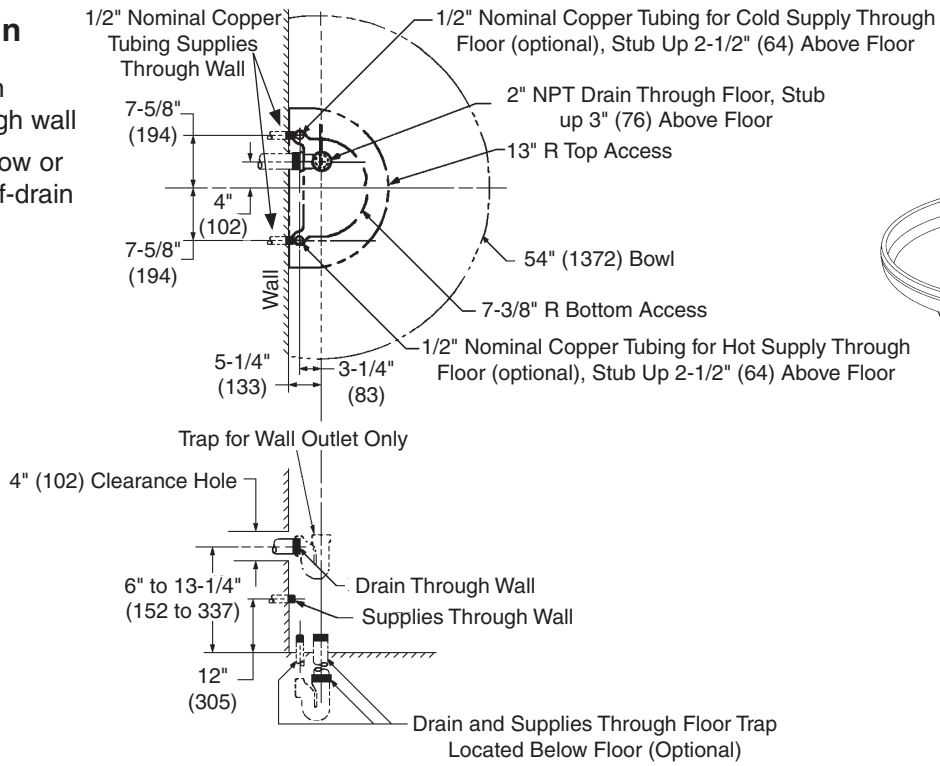

## Type B Drain

(mm)

- Supplies from above
- Vent through ceiling off trap inside pedestal

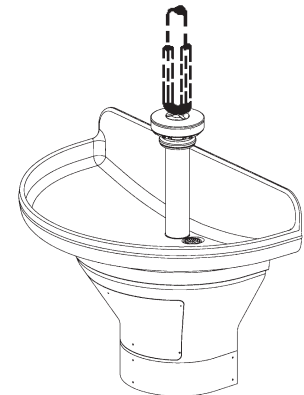
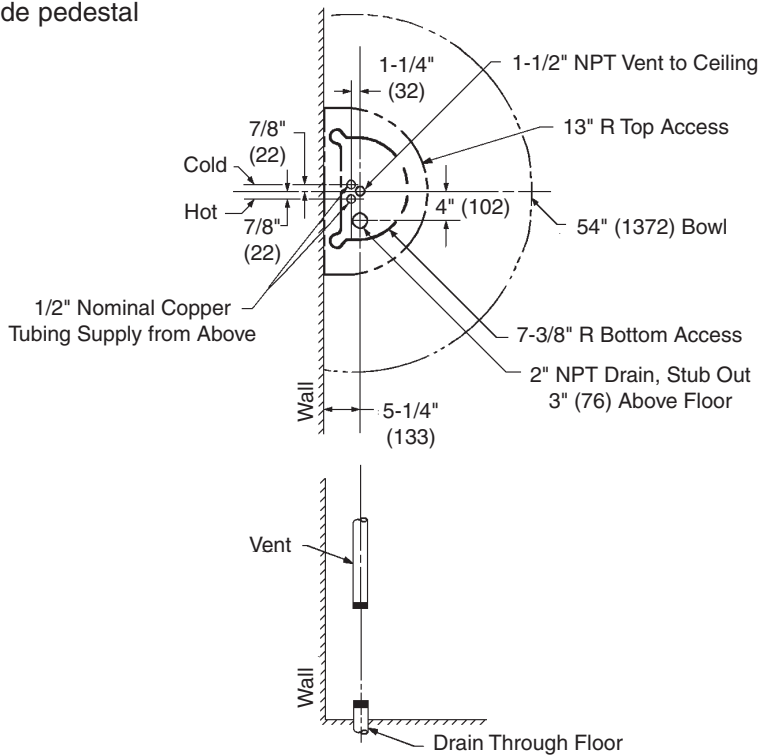



# Rough-In Specifications

(mm)

## Type H Drain

- Supplies from below or through wall
- Vented through ceiling off trap inside pedestal

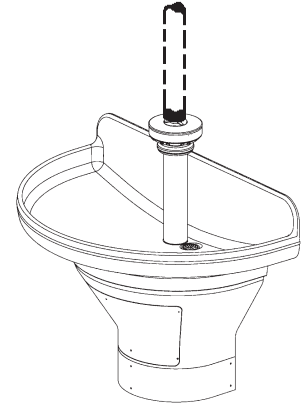
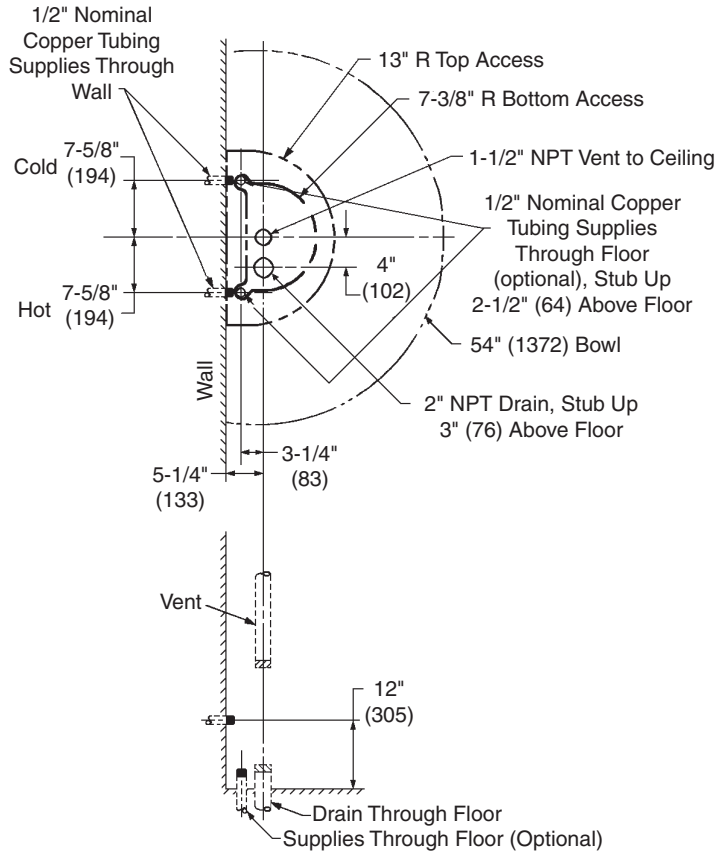

## Type O Drain

- Supplies from above
- Vented from below or through wall off drain

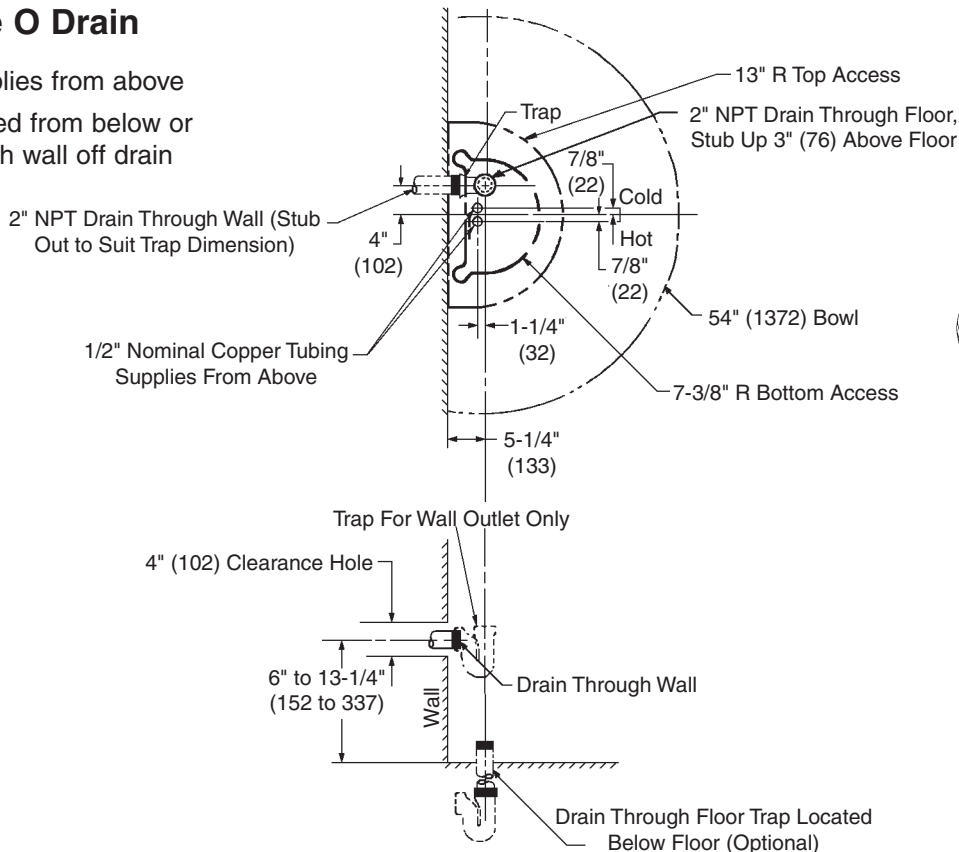

(mm)

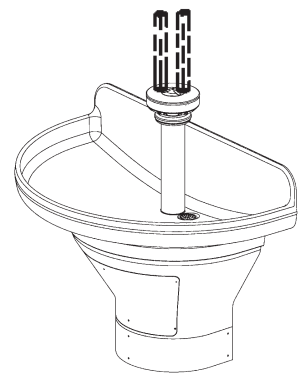





# 1 Installing the Drain



All piping shown in dotted lines to be supplied by installer.

- A** Rough in supply and drain piping as required for your installation.
- B** Assemble the drain to the dimension for the bowl you are installing.

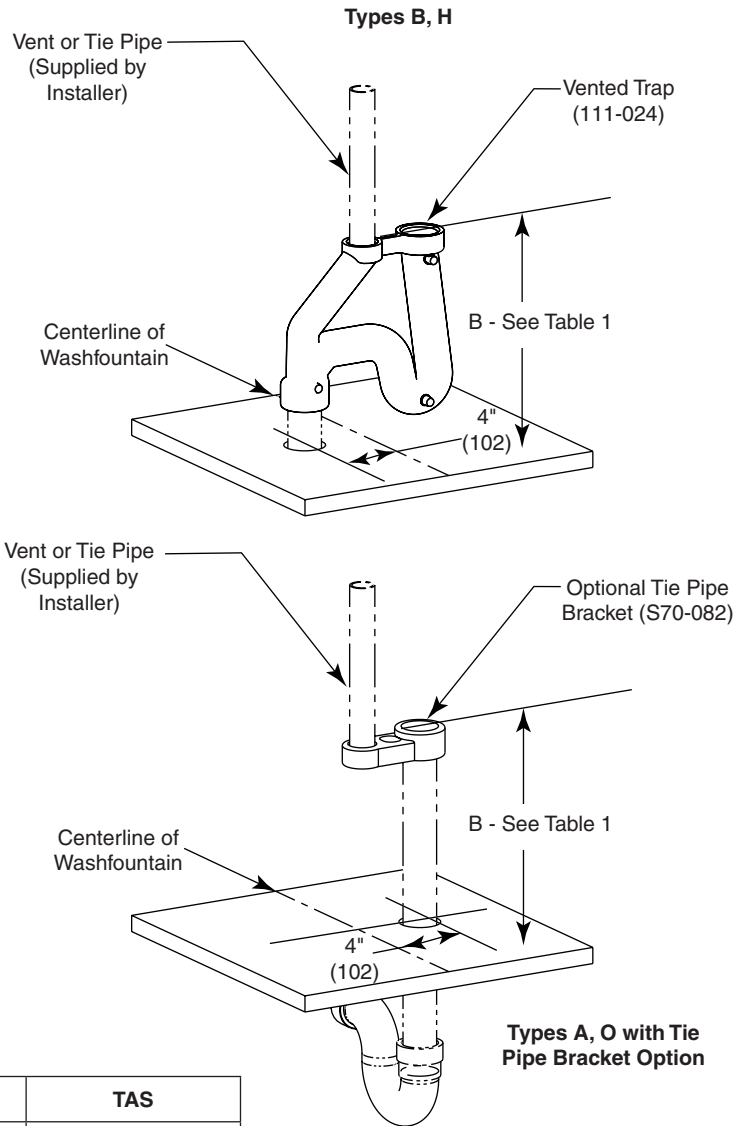
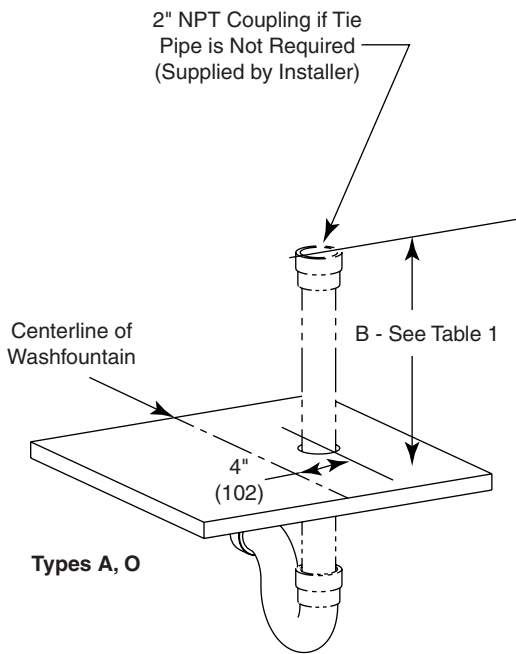

See Rough-In information for dimensions not shown.

Dim	Standard Height	Juvenile Height	TAS
B	23-3/8" (594mm)	22-1/2" (572mm)	24-1/2" (622mm)



## 2 Bowl/Pedestal Mounting and Assembly

**A** Position the pedestal at desired location and mark the position of the (2) pedestal wall mounting locations and (2) pedestal floor mounting locations.

**TAS OPTION:** Place TAS spacer on floor over the mounting holes. Place pedestal on top of the spacer.

**B** Secure pedestal to floor with suitable fasteners, 1/2" anchors and bolts (supplied by installer). Do not overtighten.

**C** Using two to three people, carefully lift bowl onto pedestal.

**D** Position the bowl so that the threaded rods in the bowl mate with the slotted holes in the pedestal.

**E** Using 1/4" wing nuts and washers, secure the bowl to the pedestal, three places.

**CAUTION!** Bowl surface is very smooth. Approximate weight of bowl is 146 pounds (model TDB3104), 136 pounds (model WF3204) or 101 pounds (model TDB3104/JUV). Handle with Care!

Top View

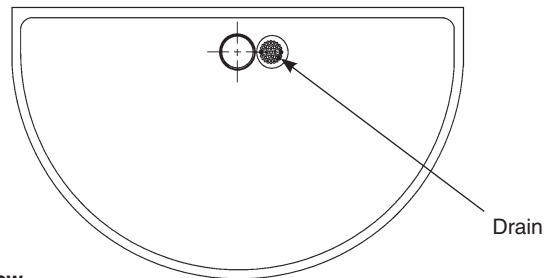

Front View

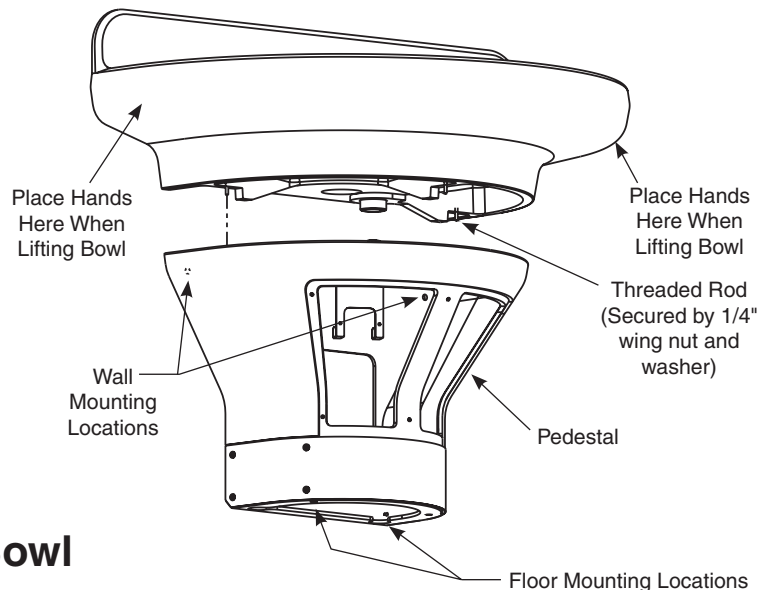

## 3 Installing Drain Spud in Bowl

**A** Loosely attach the drain spud to the bowl with the locknut and washer.

**B TRAP OPTION:** attach B trap to drain spud.

**Tie Pipe OPTION:** attach tie pipe bracket to drain spud.

**B** Tighten the spud and lock nut against the bowl.

**C** Secure the strainer to drain spud with the screws provided.

**D** Connect spud (or B Trap or Tie Pipe Bracket) to drain.



Seal between drain spud and drain hole with plumber's putty (supplied by installer).

Drain Pre-Pack (S45-273)

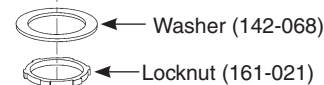
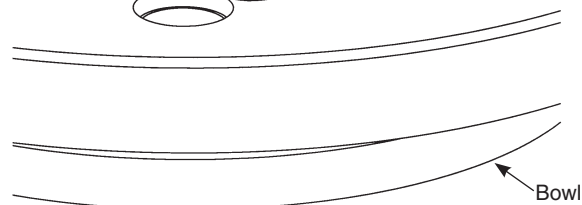
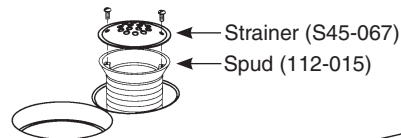



## **Cleaning and Maintenance for Terreon®**

**Material Description:** Terreon is a densified solid surface material composed of bio based resin and is resistant to chemicals, stains, burns and impact. Surface can be easily repaired with everyday cleansers or fine grit abrasives. Because Terreon is a unique cast material, its aggregate flow and distribution, and shades of color can vary from product to product creating natural characteristics.

**Routine Cleaning:** For regular cleaning, use mild neutral base cleaners.

**Stubborn Stains:** Remove tough stains with Soft-Scrub® and a green Scotch-Brite® pad or lightly sand in a circular motion with 240 grit wet/dry sandpaper. The finish can then be renewed with a maroon Scotch-Brite pad.

**Scratches:** Remove scratches with a green Scotch-Brite pad. The finish can then be renewed with a maroon Scotch-Brite pad.

**Hard Water Deposits:** Remove hard water deposits with a mild solution of vinegar and water. Always rinse the unit thoroughly after cleaning.

**Restoring the surface:** Use Hope's® Perfect Countertop to refresh and protect the Terreon Solid Surface material. Dark Terreon colors may require additional care and maintenance. For complete instructions on this additional maintenance, visit [bradleycorp.com](http://bradleycorp.com).

**Repair Kits:** Terreon repair kits are available. Contact your Bradley representative or distributor for part numbers and pricing. Repair kits are made to order and have a shelf life of 30 days.

**NOTICE!** Do not use strong acid or alkaline chemicals and cleaners to clean Terreon. If these chemicals come in contact with the surface, wipe them off immediately and rinse with soapy water. Avoid contact with harsh chemicals such as paint remover, bleach, acetone, etc. Avoid contact with hot pans and objects.

## **Cleaning/Maintenance Instructions for Gel-coated Fiberglass**

**Material Description:** The Terreon Washfountains referenced in this installation manual use a gel-coated fiberglass pedestal.

**Routine Cleaning:** The gel-coated pedestal should be cleaned daily or as often as needed with a mild solution of detergent and water. Always use a soft cloth to avoid damage to the finish.

**Repair Kits:** There are no repair kits available for fiberglass materials. However, replacement parts are available, contact your Bradley representative for pricing and part numbers.

**NOTICE!** Do not expose gel-coated fiberglass to solvents as they will damage the material and may create harmful fumes.

**Brand Names:** Use of brand names is intended only to indicate a type of cleaner. This does not constitute an endorsement, nor does the omission of any brand name cleaner imply its inadequacy. Many products named are regional in distribution, and can be found in local supermarkets, department and hardware stores, or through your cleaning service. It is emphasized that all products should be used in strict accordance with package instructions.



# Sprayheads WF2500, WF2600, WF2700, WF2800, WF3200, TDB3100 Series

P.O. Box 309 • Menomonee Falls, WI 53052-0309 • 1 800 BRADLEY • 262 251 6000 • bradleycorp.com

## Sectional Sprayhead

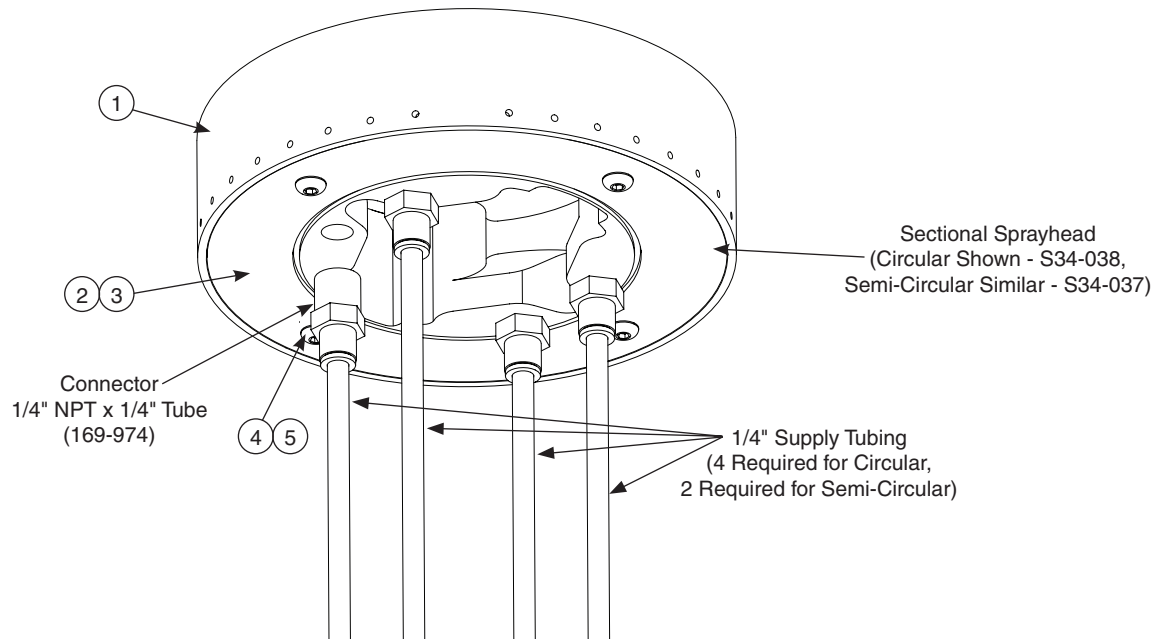

## Parts List

Item	Part No.	Description	Circular	Semi-Circular
			Qty	
1	115-080	Sectional Sprayhead - Plated (Circular)	1	
1	115-079	Sectional Sprayhead - Plated (Semi-Circular)		1
2	159-115	Bottom Plate	1	1
3	124-032	Gasket	1	1
4	160-138	Screw, 10-24 x 1/2" Button Head	4	4
5	142-002BT	Washer, #10, Split Lock	4	4



## Non-Sectional Sprayhead



*Repair kit does not include sprayhead grommet. Order as a separate item.*

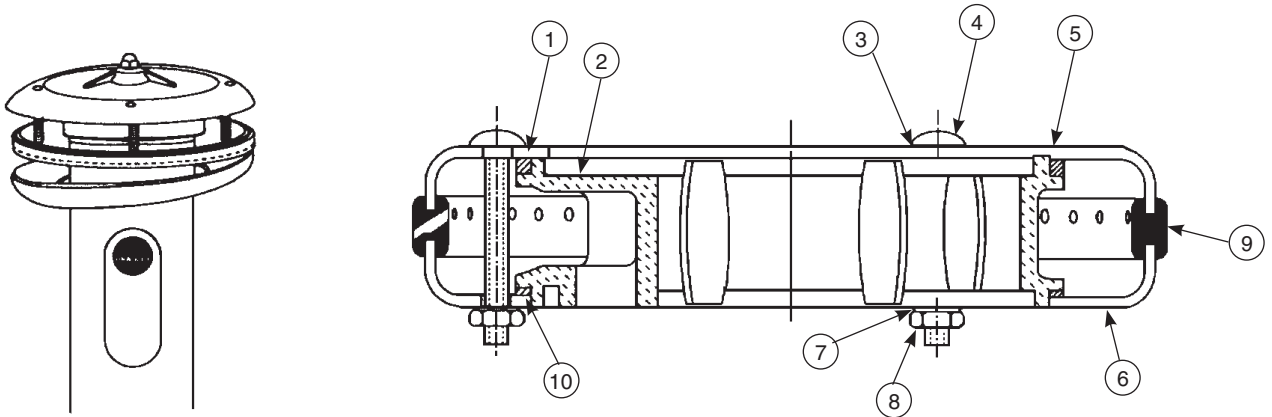

### Parts List

Item	Part No.	Description	Sprayhead Assembly	Repair Kit S45-051
			Qty	
1	125-001DE	Neoprene Washer - Top	1	1
2	139-031	Sprayhead Manifold	1	-
3	124-001AL	Washer	3	4
4	160-211	Carriage Bolt	3	4
5	115-061	Sprayhead Top	1	-
6	116-008	Sprayhead Bottom	1	-
7	124-001AT	Washer	3	4
8	161-025	Nut	3	4
9	124-020C	Sprayhead Grommet - Circle	1	-
9	120-020D	Sprayhead Grommet - Semi-Circle	1	-
9	120-020E	Sprayhead Grommet - Corner	1	-
10	125-001DF	Neoprene Washer - Bottom	1	1



## Sprayhead Troubleshooting

Problem	Cause	Solution
Water splashes over the rim of the bowl.	Foreign matter has reduced the size of the sprayhead slots, causing greater pressure at the open slots.	Clean the sprayhead: <ol style="list-style-type: none"> <li>1. Disassemble the sprayhead and dislodge any dirt, lime build-up and foreign debris with a wire brush.</li> <li>2. Sprayheads with rubber grommet spray rings may be cleaned by rubbing a coin over the grommet.</li> </ol>
		Throttle down the volume control (water spray should strike the bowl without splashing outside of the bowl).
Water flow diminishes from the sprayhead.	Strainer portion of the stop-strainer-check valve is plugged.	Remove and clean the strainer screen from the stop-strainer-check valve.  <i>The non-sectional sprayhead includes a perforated neoprene spray ring grommet that is self-cleaning. The water pressure flexes the spray holes which slows accumulation of foreign matter and tends to "break loose" any such deposits that may have accumulated.</i>

## Sprayhead Tubing Connections

**⚠ WARNING** Flush supply lines before making connections.

**A** Using a sharp razor, cut tubing squarely and remove any burrs. DO NOT pinch or crush end of tubing.

**B** Loosen nut on fitting. Moisten end of tube and push into fitting until it is firmly seated. Tighten nut to secure tube to fitting (make sure nut is securely tightened).

**C** If connector leaks, reseal tubing according to above procedure. If leaking persists, replace male connector, or call a Bradley representative for assistance.

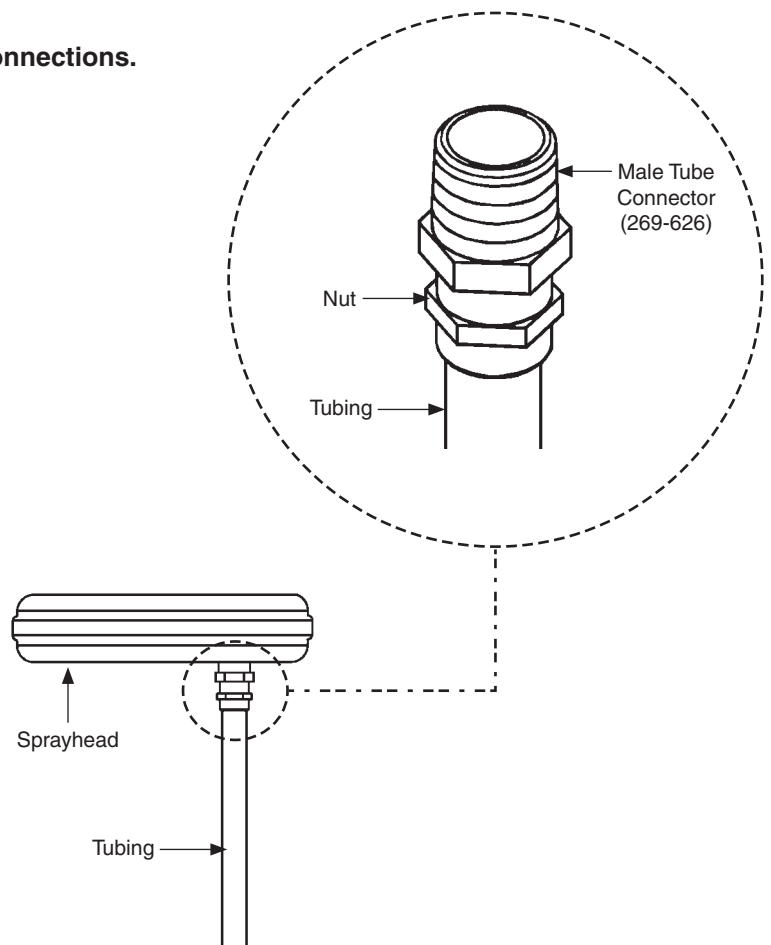



## Supplies Required by Installer

- (4) 1/2" lag bolts, screws or other fasteners to anchor washfountain to pedestal
- 1/2" nominal copper tubing for hot and cold water supply lines
- Standard p-trap (vented trap supplied by Bradley when required)
- 2" drain lines and fittings
- 1-1/2" vent or tie pipe on fixtures vented through washfountain column
- Teflon tape or pipe dope

## Pre-Installation Information

### Cylindrical Air Valve

The air valve pushbutton allows each user to activate an air metering valve (starting the flow of water) by pushing and releasing the pushbutton. The air metering valve is factory-preset to run for 10 seconds and can be adjusted to run from 5-60 seconds.



*Not all equipment shown in this document is available on all washfountains shown within these pages. See Tech Data for optional equipment available for your washfountain.*



# Air Metering Activation Modules - Non-Sectional Semi-Circular Washfountains TDB3103, WF3203, TDB3104, WF3204

P.O. Box 309 • Menomonee Falls, WI 53052-0309 • 1 800 BRADLEY • 262 251 6000 • bradleycorp.com

## 1a Air Metering Valve Assembly – A and O Units without Tie Pipe Option

**A** Install hemmed end (not sharp end) of support tube with gasket onto bowl.

**B** Place sprayhead with 3/8" tubing onto support tube. Run the tubing down through the support tube and connect to valve tube connector. Make sure the spray holes point away from the wall.

**C** Place the upper tie bar (notched at both corners of each end) on top of sprayhead parallel to wall. Connect the longer tie rod to the 4-1/4" tie rod using the coupling nut with hex head set screws. Run the tie rod assembly down through upper tie bar and secure from underneath the bowl using lower tie bar (no notches) and hex nut with socket head set screw.

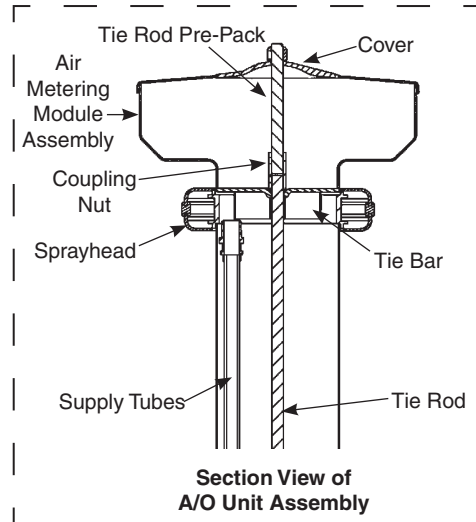

Some optional equipment shown.

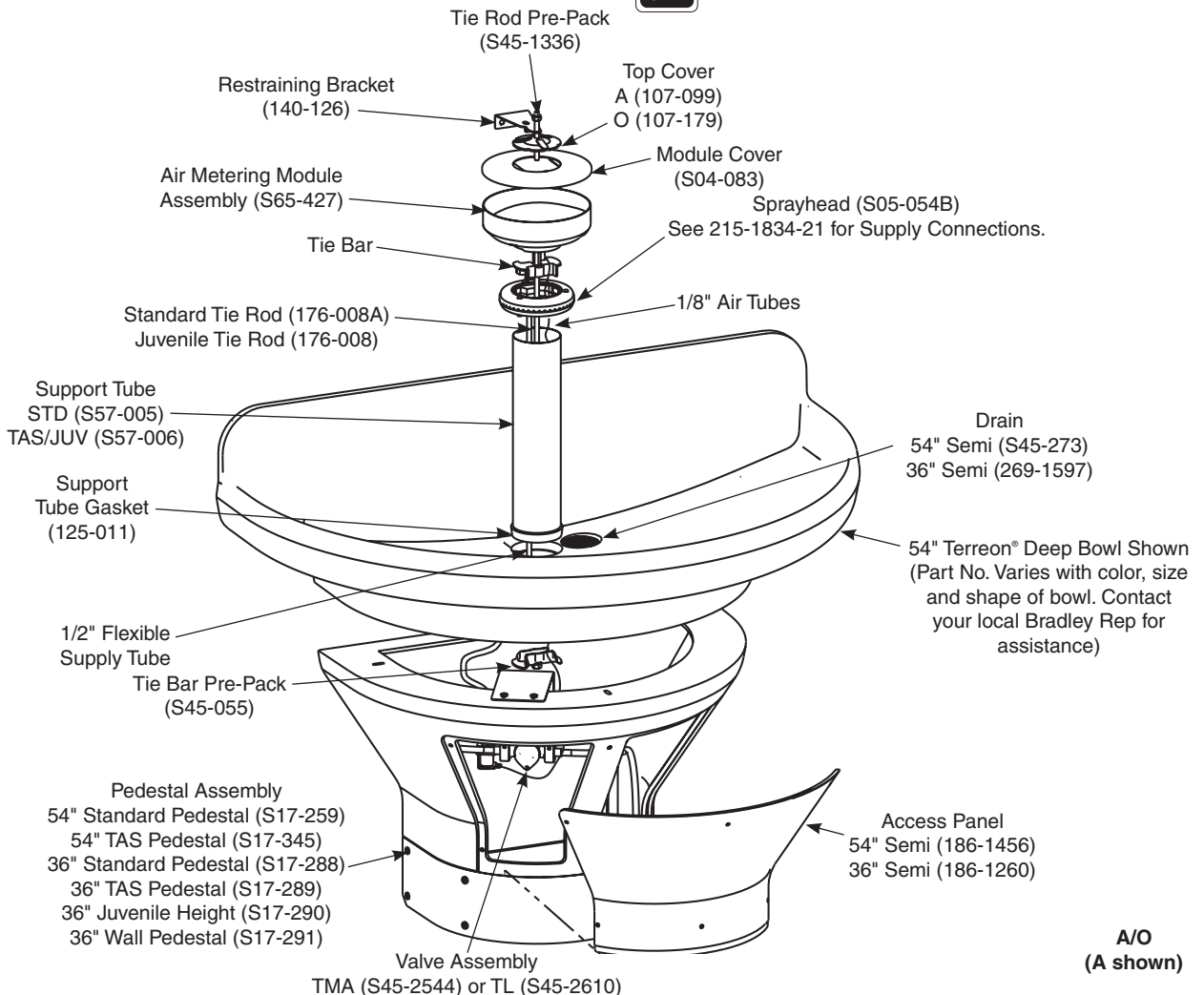

A/O  
(A shown)





# 1a Air Metering Valve Assembly – A and O Units without Tie Pipe Option

**D** Place the air metering module assembly on top of sprayhead. Rotate until the air metering module locks in with tie bar. Drop 1/8" diameter tube down to valve assembly and connect to the air valve. Make sure air valve pushbuttons are facing away from the wall.

*Skip to step F for units without soap.*

**E** For units with soap option, install the spacer, soap dispenser and cover using the third tie rod (8-5/8" long) and second coupling nut as shown. Secure with acorn nut and set screw.

**F** Secure module cover and top cover with sprayhead restraining bracket, acorn nut and set screw.

**G** Connect supply stops onto stub-outs.  
 Connect flexible hoses to supply stops.

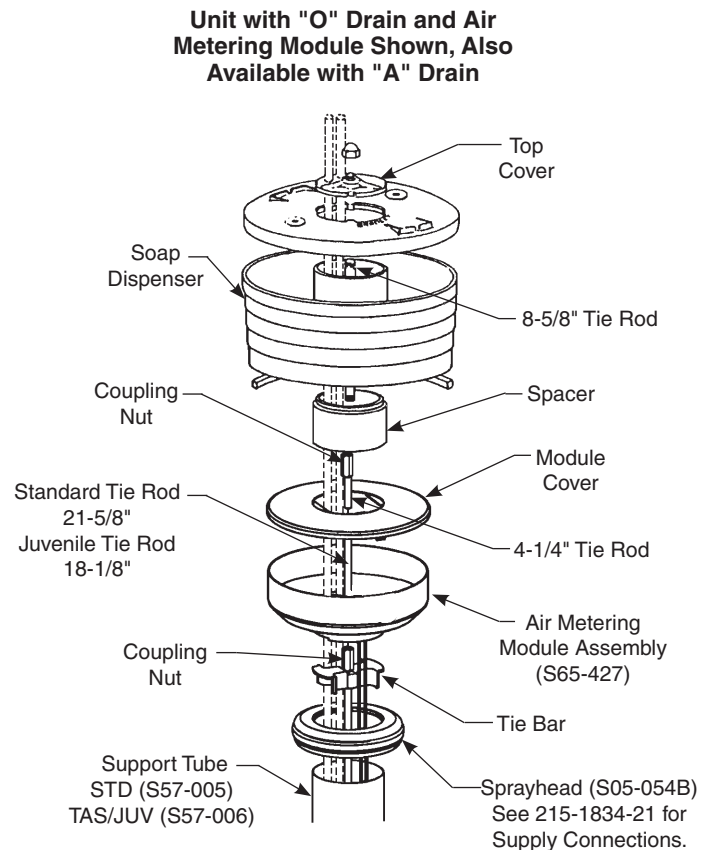

*Some optional equipment shown.*



# Air Metering Activation Modules - Non-Sectional Semi-Circular Washfountains TDB3103, WF3203, TDB3104, WF3204

P.O. Box 309 • Menomonee Falls, WI 53052-0309 • 1 800 BRADLEY • 262 251 6000 • bradleycorp.com

## 1b Air Metering Valve Assembly for B Drain and H Drain Units with Tie Pipe Option

**A** Install hemmed end (not sharp end) of support tube with gasket onto bowl.

**B** Place sprayhead with 3/8" tubing onto support tube. Run the tubing down through the support tube and connect to valve tube connector. Make sure the spray holes point away from the wall.

**C** Insert the 1-1/2" vent pipe (supplied by installer) down through the support tube and thread into vented trap.

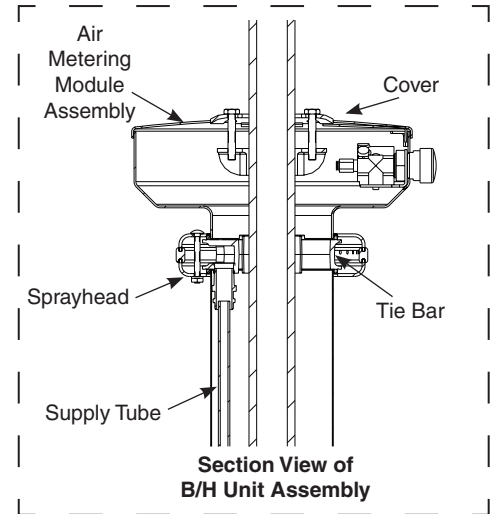

Some optional equipment shown.

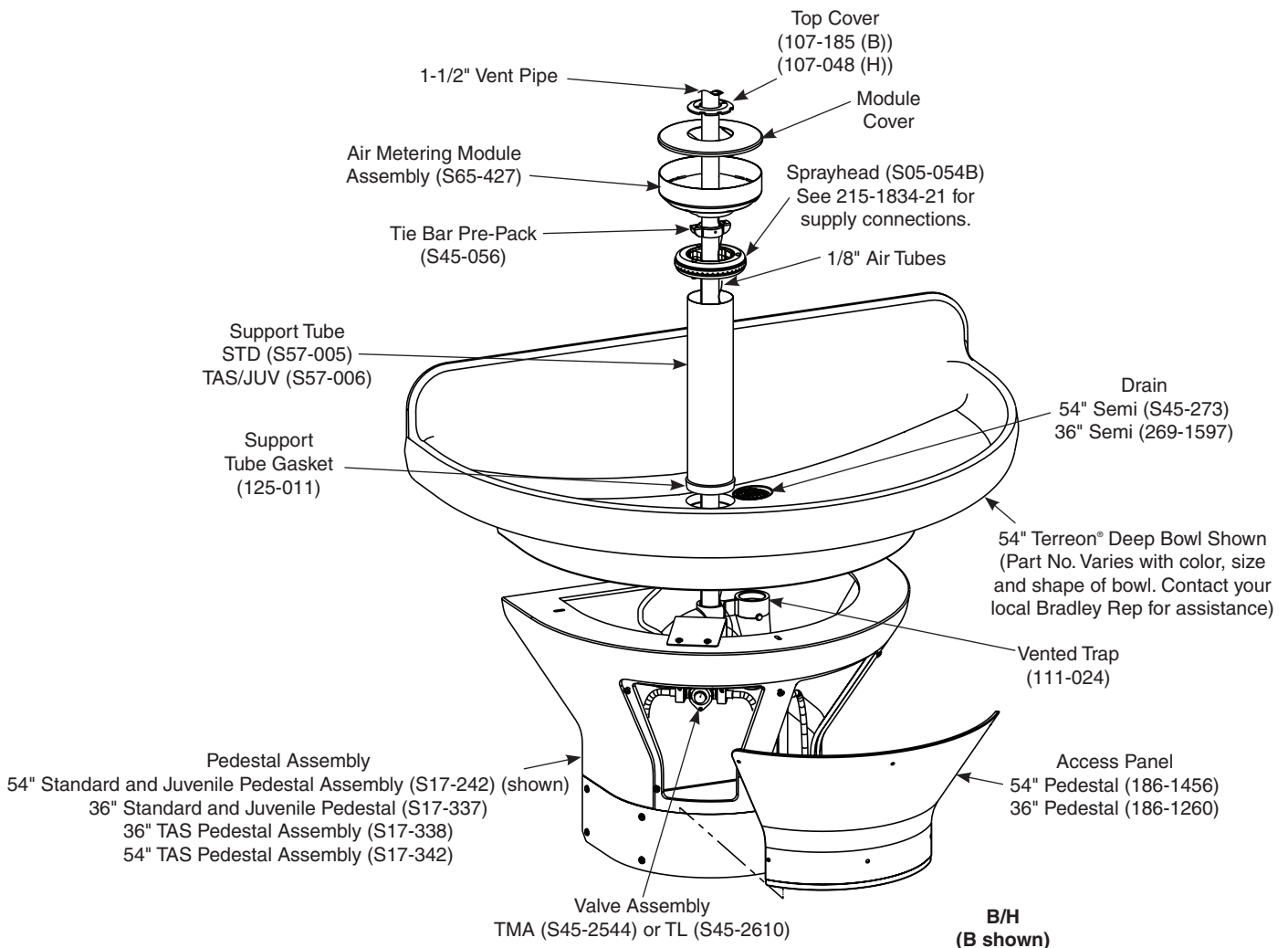



# 1b Air Metering Valve Assembly for B Drain and H Drain Units with Tie Pipe Option

**D** Place the air metering module assembly on top of sprayhead. Rotate until the air metering module locks in with tie bar. Drop 1/8" diameter tube down to valve assembly and connect to the air valve. Make sure air valve pushbuttons are facing away from the wall.

Skip to step F for units without soap.

**E** For units with soap option, slide the spacer and soap dispenser over the 1-1/2" pipe.

**F** Position the upper tie bar slightly below the module or soap dispenser and fasten securely to vent pipe with set screws provided. Secure top cover to tie bar with two cap screws provided.

**G** Connect supply stops onto stub-outs.  
 Connect flexible hoses to supply stops.

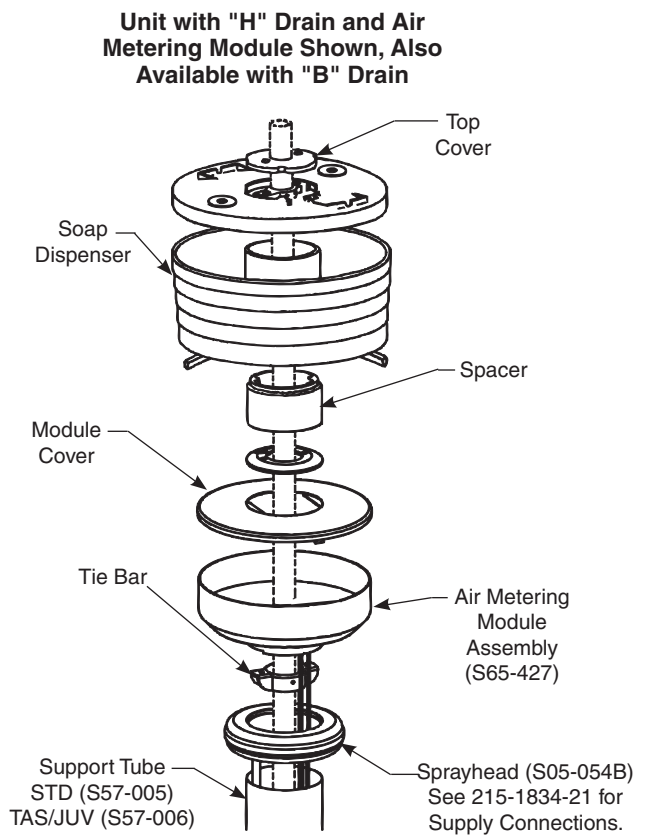

Some optional equipment shown.



## 2 Connect Valve and Tubing for Non-Sectional Air Metering Activation



*Flush supply lines before making connections.*

**A** Connect 3/8" dia. tubing to tee and ball valve, two places. The male connector for the valve assembly will remain tight and leakproof when tubing is cut and installed properly. Follow the procedures below when installing tubing to ensure that you achieve a leakproof seal.

- Using a sharp razor, cut tubing squarely and remove any burrs. **DO NOT** pinch or crush end of tubing.
- Loosen nut on fitting. Moisten end of tube and push into fitting until it is firmly seated. Tighten nut to secure tube to fitting (make sure nut is securely tightened).
- If connector leaks, reseal tubing according to above procedure. If leaking persists, replace male connector, or call your Bradley representative for assistance.



*For "O" and "B" units (overhead supplies) skip steps C through E.*

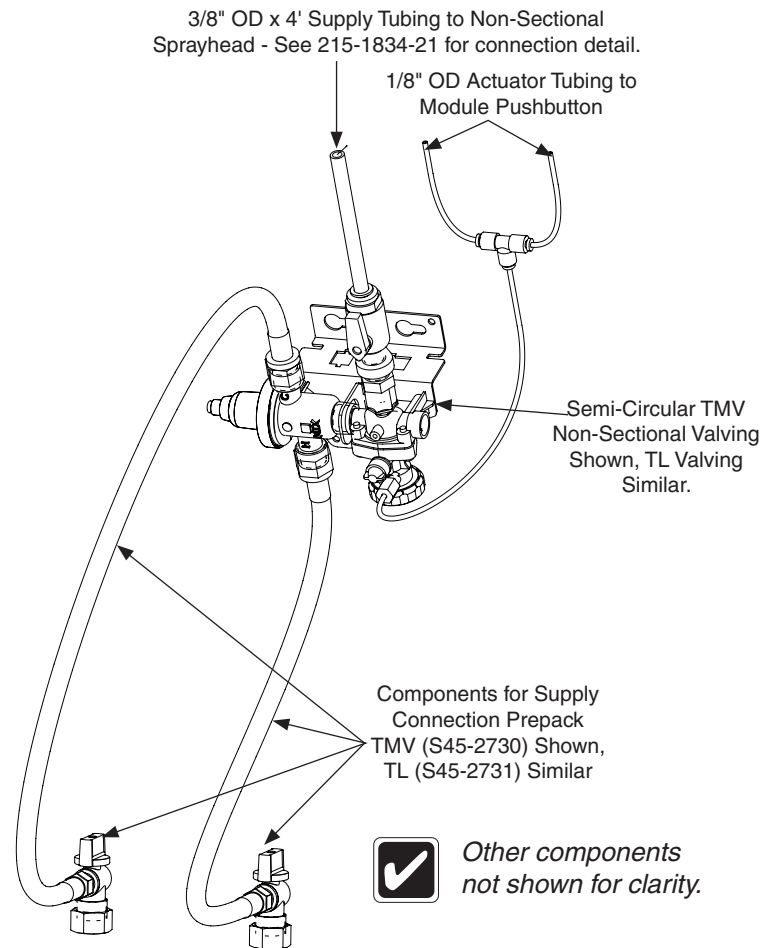

*Other components not shown for clarity.*



# Air Metering Activation Modules - Non-Sectional Semi-Circular Washfountains TDB3103, WF3203, TDB3104, WF3204

P.O. Box 309 • Menomonee Falls, WI 53052-0309 • 1 800 BRADLEY • 262 251 6000 • bradleycorp.com

## 2 Connect Valve and Tubing for Non-Sectional Air Metering Activation (Cont...)

- B** Hang valve assembly on pedestal bracket. Use included #10-24 screws to secure.
- C** Use wire tie to secure valving to valve bracket.
- D** Connect the 1/2" NPT female end of the stop/check valves to the rough-ins.
- E** Attach flexible hosing to thermostatic mixing valve, two places.
- F** Insert the filter washers (provided) into the swivel nut at the end of the supply hoses and connect to the stop/check valves.
- G** Check to make sure both Stop/Check valves and volume control valve is fully open.
- H** Turn on the main water supply and check for leaking.
- I** Push operating pushbutton until air is purged from lines.
- J** When tubing connections are complete, ball valve is to be used as volume controls to control spray pattern from sprayhead.

54" TDB Semi-Circular Valve Installation

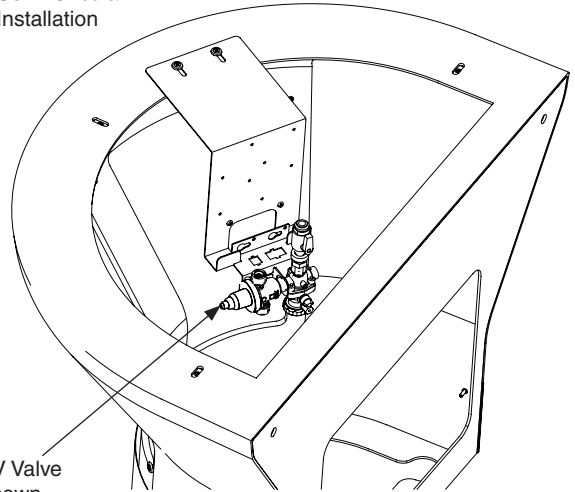

S45-2544 TMV Valve Assembly Shown, S45-2610 TL Similar (Hang on valve mounting bracket, as shown.)



*Bowl, tubing and supplies not shown for clarity.*

36" TDB Semi-Circular Valve Installation

S45-2544 TMV Valve Assembly Shown, S45-2610 TL Similar (Hang on valve mounting bracket, as shown.)

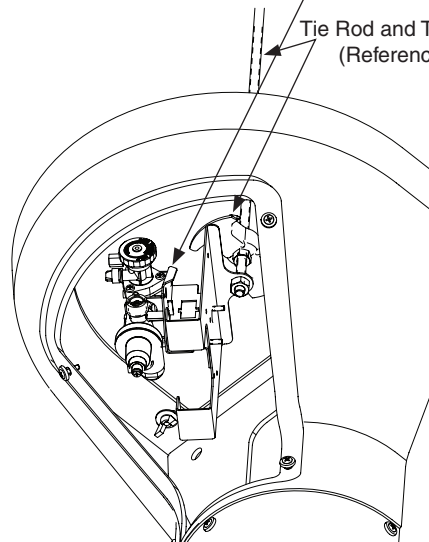
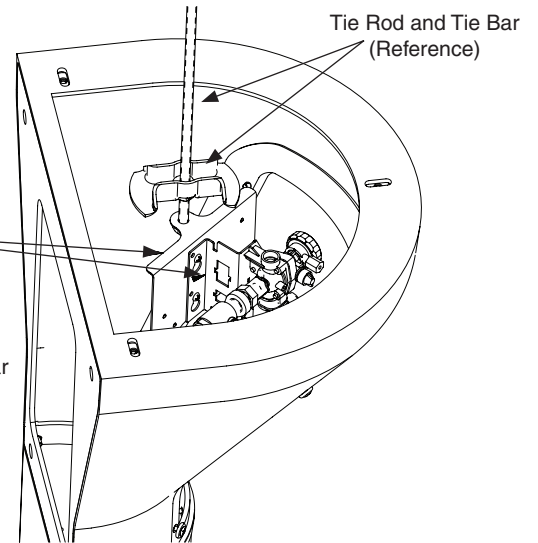

Tie Rod and Tie Bar (Reference)

Tie Rod and Tie Bar (Reference)



# Air Metering Activation Modules - Non-Sectional Semi-Circular Washfountains TDB3103, WF3203, TDB3104, WF3204

P.O. Box 309 • Menomonee Falls, WI 53052-0309 • 1 800 BRADLEY • 262 251 6000 • bradleycorp.com

## 3 Turn on Water, Test and Adjust Unit

Check to make sure stop valves are open before turning on water.

Single valve TMV assembly shown. Other AST valve assembly adjustments similar.

**A** Turn on water supply and check for leaks. Activate each push/foot button to purge air from the lines.

**B** Adjust air-valve meter timing, if desired (hand-operated units only)

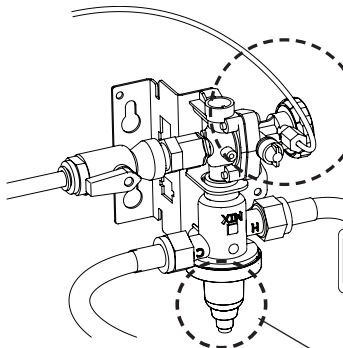

Semi-Circular TMV valve assembly shown, semi-circular TL assembly similar.

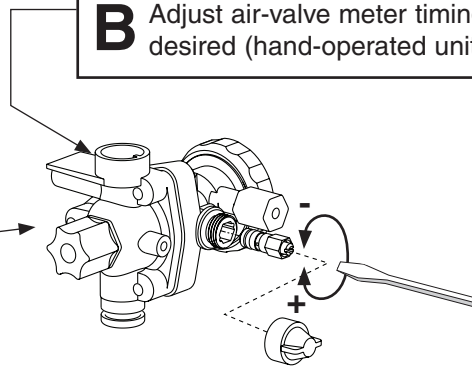

**Air Metering Timer**  
(Hand-operated push button only)

**C** Loosen the cap screw about 1/4" (4-6 turns) and lift up the cover (do not remove).

**D** Using the cover, turn the cartridge gently until desired water temperature is reached. Do not turn past stops as this may damage the unit. Push the cover down and tighten the screw.

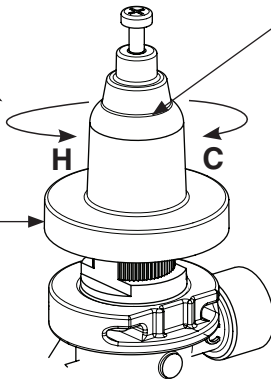

This valve is NOT factory preset. Upon installation, the temperature of this valve must be checked and adjusted to ensure delivery of a safe water temperature. Water in excess of 110°F (43°C) may cause scalding.

## Air Metering Module Components

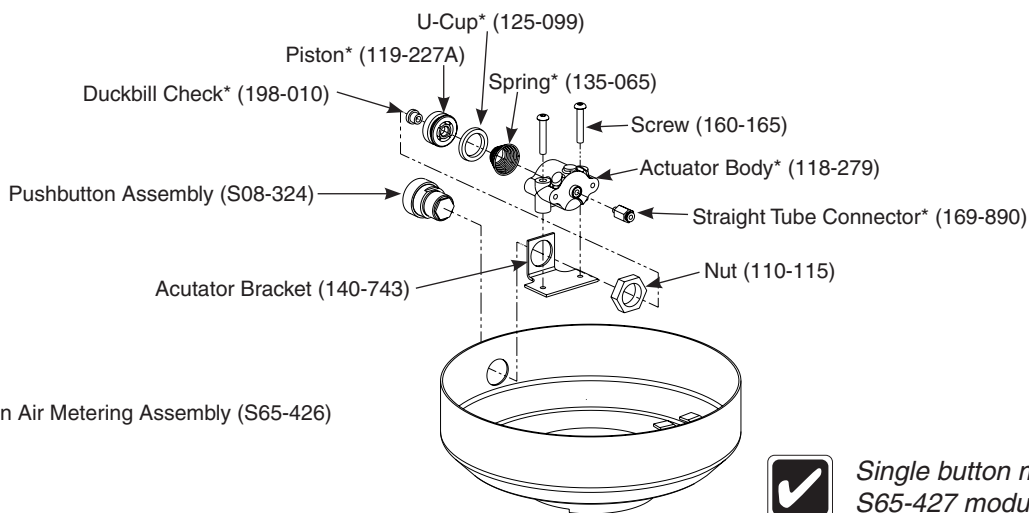

\* Included in Air Metering Assembly (S65-426)

Single button module shown. S65-427 module has 2 buttons.



## Metering Air Valve Maintenance

- ✓
 The air valve timer is located next to the tube connector on the air valve body. The timer is capped with a filter to prevent dirt build-up on the timer. The air valve timing can be adjusted from 5–60 seconds.

## Adjust Air Valve Meter Time

**A** Remove filter cap and use a screwdriver to tighten or loosen the timer (see illustration at right). Turning the timer clockwise increases the time; turning the timer counterclockwise decreases the time.

**B** Continue to adjust until the timer is set at desired length.

**C** Replace filter cap over the timer.

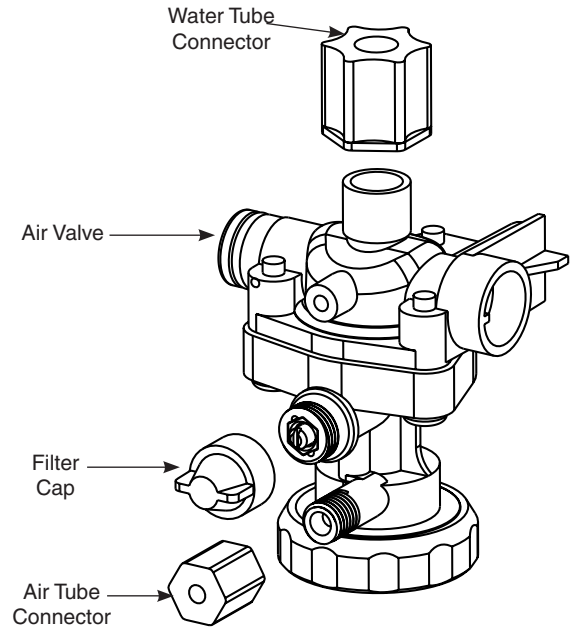

## Tube Connection Leaks

**A** Push in the orange manual release button while pulling the tube out (see illustration at right) to disconnect the tube at the connector. No tools are needed.

**B** To correct a leak, press tubing firmly into the connector and make sure it is seated.

**C** If leak persists, remove tubing from the fitting, and trim the tubing end square with a razor-sharp knife. If leak continues, replace the fitting or contact your Bradley representative for assistance.

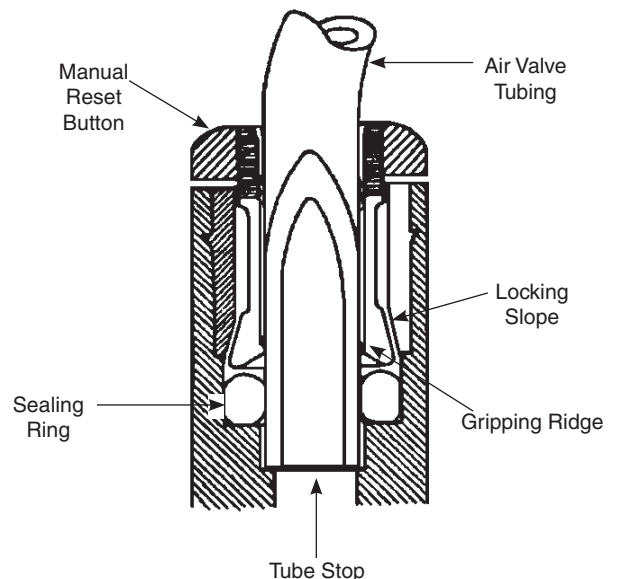



# Air Metering Activation Modules - Non-Sectional Semi-Circular Washfountains TDB3103, WF3203, TDB3104, WF3204

P.O. Box 309 • Menomonee Falls, WI 53052-0309 • 1 800 BRADLEY • 262 251 6000 • bradleycorp.com

## AST4 Valve Repair Kits

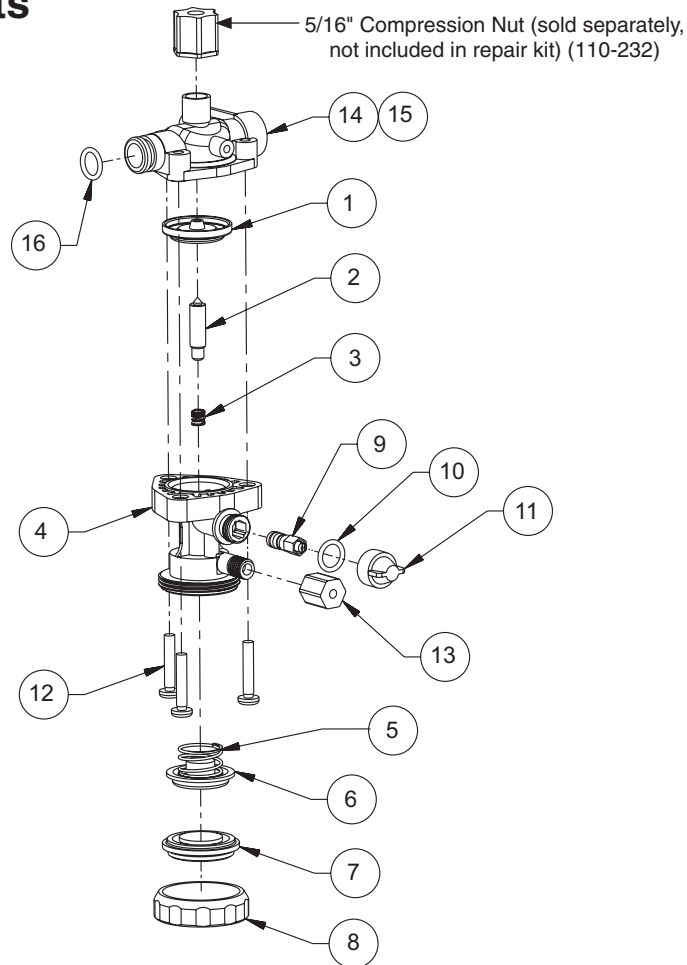

## AST4 Valve Repair Kits

Item	Description	AST 4 Valve Kit S65-260	Repair Kit (Upper) S65-261	Repair Kit (Lower) S65-262	AST4 5/16" Tube Valve S07-079S	AST4 5/16" Tube Valve S07-079AS
		Qty				
1	Diaphragm	1	—	1	1	1
2	Armature	1	—	1	1	1
3	Spring	1	—	1	1	1
4	AST 4 Valve Upper Body	1	—	—	1	1
5	Spring	1	1	—	1	1
6	Magnet / Diaphragm Assembly	1	1	—	1	1
7	AST 4 Valve Cover	1	1	—	1	1
8	AST 4 Valve Clamp Nut	1	1	—	1	1
9	AST 4 Valve Timer Assembly	1	—	—	1	1
10	O-Ring, #2-012	1	—	—	1	1
11	AST 4 Valve Timer Cover	1	—	—	1	1
12	Screw, #8 x 7/8"	3	—	—	1	1
13	Compression Nut, 1/8" Tube	1	1	—	1	1
14	Valve Body 5/16 Tube, Closed	—	—	—	1	—
15	Valve Body 5/16 Tube, Thru	—	—	—	—	1
16	O - Ring	—	—	—	1	1





# Air Metering Activation Modules - Non-Sectional Semi-Circular Washfountains TDB3103, WF3203, TDB3104, WF3204

P.O. Box 309 • Menomonee Falls, WI 53052-0309 • 1 800 BRADLEY • 262 251 6000 • bradleycorp.com

## Metering Air Valve Trouleshooting

Problem	Cause	Solution
Valve will not shut off.	Timing mechanism is clogged.	Clean and inspect timing mechanism. <ol style="list-style-type: none"> <li>1. If compressed air is available, blow water and debris from timer cover of timing mechanism.</li> <li>2. Turn adjusting screw out all the way. Clean and inspect screw and valve body.</li> <li>3. Turn adjusting screw in to desired cycle time.</li> </ol>
Valve will not turn on.	Water is not being supplied to unit.	Open all stops on mixing valve.
	Water pressure is over 80 PSI.	Install a pressure reducing valve.
	Failed diaphragm/magnet assembly.	Unscrew the valve clamp nut on valve. Remove valve cover. Gently press the diaphragm. The valve should activate. If not, replace the diaphragm/magnet assembly.
Timing can not be adjusted for more than 5 seconds.	There is an air leak.	Check the valve assembly. <ol style="list-style-type: none"> <li>1. Check all tubing and fittings for proper assembly.</li> <li>2. Tighten cap and nut on 1/8" tubing.</li> </ol>
Pushbutton does not work properly.	Air volume may not be sufficient to operate valve.	Check for leaks and lubricate U-cup. <ol style="list-style-type: none"> <li>1. Check all fittings for air leaks.</li> <li>2. Disassemble pushbutton and lubricate U-cup seal.</li> </ol>
Water is dripping from the steamformers.	Debris has accumulated on valve seat or orifices.	Clean and inspect valve seat. <ol style="list-style-type: none"> <li>1. Remove screws and disassemble metering valve.</li> <li>2. Clean valve seat and inspect for deep gouges or scratches. Replace valve body if necessary.</li> <li>3. Remove any debris clogging off-center whole in rubber diaphragm.</li> </ol>



## Troubleshooting – Metering Air Valve



Turn off water supplies to the unit before troubleshooting.

Item	Qty.	Description
1	1	Diaphragm
2	1	Armature
3	1	Spring
4	1	AST 4 Valve Upper Body
5	1	Spring
6	1	Magnet/Diaphragm Assembly
7	1	AST 4 Valve Cover
8	1	AST 4 Valve Clamp Nut
9	1	AST 4 Valve Timer Assembly
10	2	O-Ring
11	1	AST 4 Valve Timer Cover
12	3	Screw, #8 x 7/8"
13	1	Compression Nut, 1/8" Tube
14	1	Compression Nut, 5/16" Tube
15	1	O-Ring

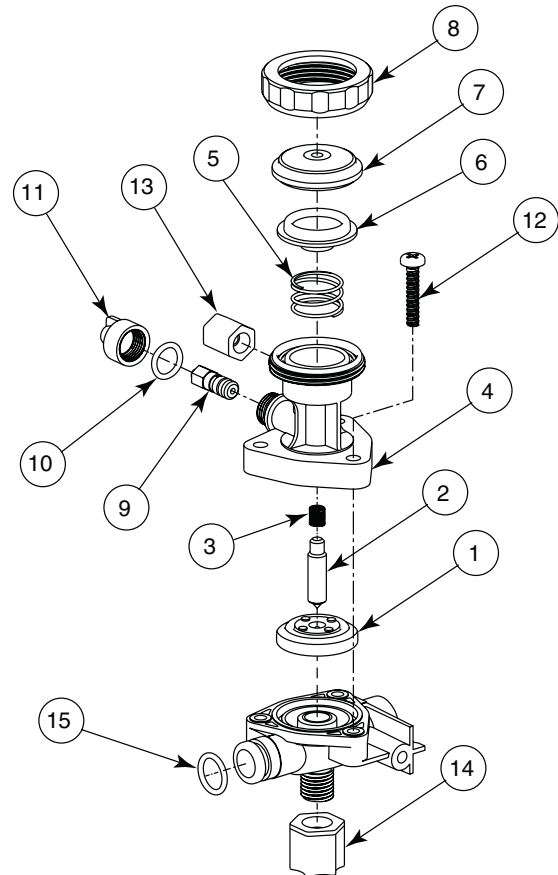

Problem	Cause	Solution
Valve will not shut off.	Timing mechanism is clogged.	Clean and inspect timing mechanism: 1. If compressed air is available, blow water and debris from timer cover of timing mechanism. 2. Turn adjusting screw out all the way. Clean and inspect screw and valve body. 3. Turn adjusting screw in to desired cycle time.
Valve will not turn on.	Water is not being supplied to unit.	Open all stops on mixing valve.
	Water pressure is over 80 PSI.	Install a pressure reducing valve.
	Failed diaphragm/magnet assembly.	Unscrew the valve clamp nut on valve. Remove valve cover. Gently press the diaphragm. The valve should activate. If not, replace the diaphragm/magnet assembly.
Timing can not be adjusted for more than 5 seconds.	There is an air leak.	Check the valve assembly: 1. Check all tubing and fittings for proper assembly. 2. Tighten cap and nut on 1/8" tubing.
Pushbutton does not work properly.	Air volume may not be sufficient to operate valve.	Check for leaks and lubricate U-cup: 1. Check all fittings for air leaks. 2. Disassemble pushbutton and lubricate U-cup seal (see pushbutton assembly diagram).
Water is dripping from the streamformers.	Debris has accumulated on valve seat or orifices.	Clean and inspect valve seat: 1. Remove screws and disassemble metering valve. 2. Clean valve seat and inspect for deep gouges or scratches. Replace valve body if necessary. 3. Remove any debris clogging off-center hole in rubber diaphragm.



## Thermostatic Mixing Valve Troubleshooting

Before attempting to troubleshoot the valve or disassemble the components, check for the following conditions:

- If stop valves are used, make sure that they are fully open.
- Make sure that the hot and cold inlet pipes are connected properly, and that there are no cross-connections or leaking stop valves.
- Check the hot water heater output to make sure that it is at least 10° F above the set temperature.



*Be sure to close the appropriate shut-off valves prior to disassembly of the valve and reopen the valves after inspection and repair is complete.*

Problem	Cause	Solution
External leaks.	Damaged cartridge or O-rings.	Replace cartridge with part number 269-1927
Improper water temperature or temperature fluctuation.	Hot water supply is not 10° above desired set point.	Increase hot water supply temperature
	Valve temperature is not properly set.	Adjust the temperature as previously shown in this installation manual.
Limited water flow.	Dirt and debris have built up in the valve or strainer.	<ol style="list-style-type: none"> <li>1. Check to make sure both hot and cold supplies are connected to the Navigator mixing valve and that they have water flow.</li> <li>2. Remove cover and U-clip. Remove the cartridge and clean the strainer. It is not required to grease cartridge, however if desired, use silicone grease only. Do not use grease on check valves.</li> </ol>

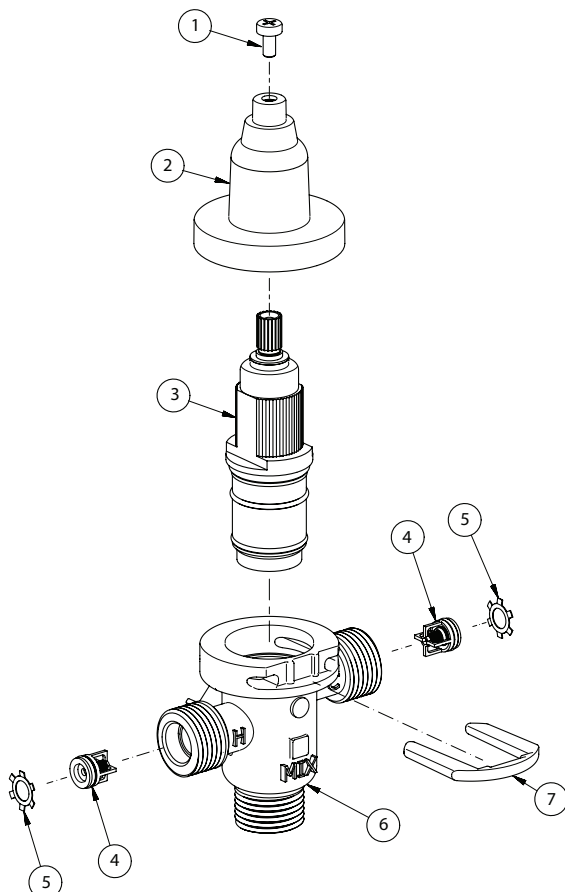

### Parts List

Item	Part No.	Description	Quantity
			S59-4000
1	160-463	Cap Screw	1
2	107-582	Cover	1
3	269-1927	Thermostatic Cartridge	1
4	198-014	Check Valve*	2
5	132-051	Retaining Ring*	2
6	118-319	Valve Body	1
7	146-079	U-Clip	1

\* Included with Prepack S65-326

**Tempered Line Adapter Option**  
**Part no. S39-804**  
 (replaces S01-526 if tempered line is used)

