

Installation

WF2605

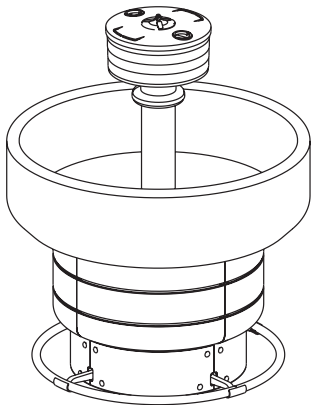

WF3203

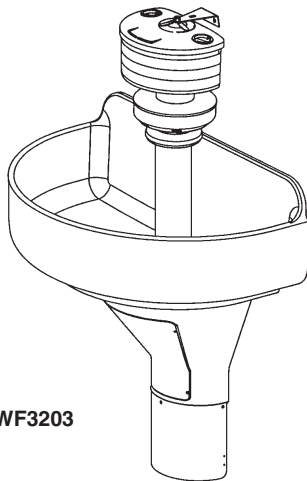

WF2500 Series Terreon Classic
WF2600 Series Terrazzo
WF2700 Series Stainless Steel
WF2800 Series Bradstone
WF3200 Series Terreon Deep Bowl
TDB3100 Series Terreon Deep Bowl

WARNING

Make sure that all water supply lines have been flushed and then completely turned off before beginning installation. Debris in the supply lines can cause valves to malfunction.

Turn OFF electrical supply to the unit before installation.

NOTICE

Main water supply to the unit should be "ON" at all times.

IMPORTANT

Read this installation manual completely to ensure proper installation, then file it with the owner or maintenance department. Compliance and conformity to drain requirements and other local codes and ordinances is the responsibility of the installer.

Separate parts from packaging and make sure all parts are accounted for before discarding any packaging material. If any parts are missing, do not begin installation until you obtain the missing parts.

Product warranties and parts information may also be found under "Products" on our web site at bradleycorp.com.





Cleaning and Maintenance for Terreon®

Material Description: Terreon is a densified solid surface material composed of bio based resin and is resistant to chemicals, stains, burns and impact. Surface can be easily repaired with everyday cleansers or fine grit abrasives. Because Terreon is a unique cast material, its aggregate flow and distribution, and shades of color can vary from product to product creating natural characteristics.

Routine Cleaning: For regular cleaning, use mild neutral base cleaners.

Stubborn Stains: Remove tough stains with Soft-Scrub® and a green Scotch-Brite® pad or lightly sand in a circular motion with 240 grit wet/dry sandpaper. The finish can then be renewed with a maroon Scotch-Brite pad.

Scratches: Remove scratches with a green Scotch-Brite pad. The finish can then be renewed with a maroon Scotch-Brite pad.

Hard Water Deposits: Remove hard water deposits with a mild solution of vinegar and water. Always rinse the unit thoroughly after cleaning.

Restoring the surface: Use Hope's® Perfect Countertop to refresh and protect the Terreon Solid Surface material. Dark Terreon colors may require additional care and maintenance. For complete instructions on this additional maintenance, visit bradleycorp.com.

Repair Kits: Terreon repair kits are available. Contact your Bradley representative or distributor for part numbers and pricing. Repair kits are made to order and have a shelf life of 30 days.

NOTICE! Do not use strong acid or alkaline chemicals and cleaners to clean Terreon. If these chemicals come in contact with the surface, wipe them off immediately and rinse with soapy water. Avoid contact with harsh chemicals such as paint remover, bleach, acetone, etc. Avoid contact with hot pans and objects.

Cleaning and Maintenance for Stainless Steel

Material Description: Stainless steel is extremely durable, and maintenance is simple and inexpensive. Proper care, particularly under corrosive conditions, is essential. Always start with the simplest solution and work your way toward the more complicated.

Routine cleaning: Daily or as often as needed use a solution of warm water and soap, detergent, or ammonia. Apply the cleaning solution per the manufacturer's instructions and always use a soft cloth or sponge to avoid damaging the finish.

Stubborn Stains: To remove stains from stainless steel use a stainless steel cleaner and polish such as Ball® stainless steel cleaner or a soft abrasive. Always follow the manufacturer's instructions and apply in the same direction as the polish lines.

NOTICE! Never use ordinary steel wool or steel brushes on stainless steel. Always use stainless steel wool or stainless steel brushes.

Fingerprints and Smears: To remove fingerprints or smears use a high quality stainless steel cleaner and polish in accordance with the manufacturer's instructions. Many of these products leave a protective coating that helps prevent future smears and fingerprints.

Grease and Oil: To remove grease and oil use a quality commercial detergent or caustic cleaner. Apply in accordance to the manufacturer's instructions and in the direction of the polish lines.

Precautions: Avoid prolonged contact with chlorides (bleaches, salts), bromides (sanitizing agents), thiocyanates (pesticides, photography chemicals, and some foods), and iodides on stainless steel equipment, especially if acid conditions exist.

NOTICE! Do not permit salty solutions to evaporate and dry on stainless steel.

The appearance of rust streaks on stainless steel leads to the belief that the stainless steel is rusting. Look for the actual source of the rust in some iron or steel particles which may be touching, but not actually a part of the stainless steel structure.

NOTICE! Strongly acidic or caustic cleaners may attack the steel causing a reddish film to appear. The use of these cleaners should be avoided.

Brand Names

Use of brand names is intended only to indicate a type of cleaner. This does not constitute an endorsement, nor does the omission of any brand name cleaner imply inadequacy. Many products named are regional in distribution, and can be found in local supermarkets, department and hardware stores, or through your cleaning service. It is emphasized that all products should be used in strict accordance with package instructions.



Cleaning and Maintenance for Terrazzo

Material Description: Terrazzo is a mosaic-looking natural stone and concrete material polished to a high gloss and sealed with clear polyurethane resin for long lasting beauty. Terrazzo is precast and composed of 85% stone and 15% binder with steel reinforcing rods cast into the bowl.

Routine Cleaning: Clean daily or as often as conditions require with any standard detergent, warm water and a soft cloth.

Stubborn Stains: If stains have permeated the surface of the terrazzo, follow instructions for restoring the surface listed below.

Restoring the surface: Use paint stripper to remove the existing polyurethane (it is important to remove all of the old polyurethane to ensure a high quality finish). Then use light grit sand paper to remove any stubborn stains that have permeated the surface. Clean and thoroughly dry the bowl. Then apply 2 to 3 coats of polyurethane to the terrazzo in accordance with the manufacturer's instructions. Allow the polyurethane to dry completely per the manufacturer's recommendations before turning on the water.

NOTICE! If the bowl is not completely dry before applying the polyurethane, the polyurethane will not adhere to the surface.

NOTICE! Make sure the surface is completely covered with polyurethane to prevent water from penetrating the surface and damaging the terrazzo.

Repair Kits: Terrazzo repair kits are available. Contact your Bradley representative or distributor for part numbers and pricing.

NOTICE! Do not place acid or alkaline solutions (floor stripper or drain cleaners) into the terrazzo bowl or use them to clean the bowl. If these solutions come into contact with the terrazzo, rinse the bowl immediately with water and inspect for damage. If damage has occurred, follow the directions for restoring the surface. If bowl begins to haze, it is usually a sign that the terrazzo has come into contact with an acid or alkaline chemical or has been exposed to UV radiation. To repair this condition, follow the instructions for restoring the surface.

Cleaning and Maintenance for Bradstone

Material Description: Bradstone is an extremely durable plastic material made of reinforced thermosetting polyester resins, finely ground inorganic fillers and fade resistant pigments. Bradstone is impervious to most chemicals and stains.

Routine Cleaning: Soap and dirt accumulations should be washed off with detergent cleaners. Abrasive and caustic cleaners are not recommended. An occasional waxing with automotive wax will make future cleaning even easier.



Bowl and Pedestal Assembly (Stainless Steel & Terrazzo) WF2605, WF2608, WF2705, WF2708

P.O. Box 309 • Menomonee Falls, WI 53052-0309 • 1 800 BRADLEY • 262 251 6000 • bradleycorp.com



This document describes installation of washfountain bowl and pedestal only. Some optional equipment and accessories are shown for clarity. For activation, optional equipment and accessory installation, see installation documents included with those parts.



Before installation of bowl and pedestal assemblies, review all included instructions. Some options may require additional steps during the bowl and pedestal installation process.

Supplies Required by Installer

- (8) 1/2" lag bolts, screws or other fasteners to anchor washfountain pedestal to floor
- 1" hot and cold water supply lines and fittings (see activation instructions)
- Reducing fittings and 1/2" nom. copper tubing supply lines for types with supplies from above (see activation instructions)
- Standard 2" P-trap (vented trap supplied by Bradley when required)
- 2" drain lines and fittings (see activation instructions)
- 1-1/2" vent pipe on types vented through washfountain column
- Pipe sealant and plumber's putty



Supply lines for one or two washfountains should be 1"; for three washfountains 1-1/4"; for more than three washfountains, pipe size should increase proportionally. Vent pipe to be 1-1/2" on models vented through washfountain.



Valving installations for Classic washfountains require rigid plumbing installation and connections to ensure proper operation and support of the valve assemblies, especially for foot control activated washfountains. Do not use flexible supply hoses unless specified in your activation instruction documentation and supplied with your washfountain.



Bowl and Pedestal Assembly (Stainless Steel & Terrazzo) WF2605, WF2608, WF2705, WF2708

P.O. Box 309 • Menomonee Falls, WI 53052-0309 • 1 800 BRADLEY • 262 251 6000 • bradleycorp.com

Circular Washfountain Dimensions

(mm)

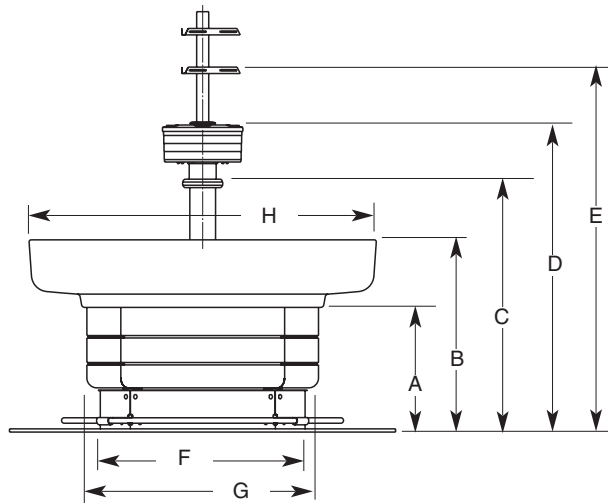

Approximate Dimensions in Inches*

| Material | Size | A | B | C | D | E | F | G | H |
|-----------|------|----|--------|--------|--------|--------|----|----|----|
| Terrazzo | 54" | 19 | 29-1/4 | 39-1/8 | 47-5/8 | 56 | 32 | 36 | 54 |
| Stainless | 54" | 19 | 28 | 37-3/8 | 45-7/8 | 54-1/4 | 32 | 36 | 54 |
| Terrazzo | 36" | 19 | 29-1/4 | 35-5/8 | 44-1/8 | 52-1/2 | 21 | 25 | 36 |
| Stainless | 36" | 19 | 28 | 33-7/8 | 42-3/8 | 50-3/4 | 21 | 25 | 36 |

*Juvenile height (terrazzo only): Subtract 4" from dimensions A through E for juvenile height.

Approximate Dimensions in Millimeters*

| Material | Size | A | B | C | D | E | F | G | H |
|-----------|--------|-----|-----|-----|------|------|-----|-----|------|
| Terrazzo | 1372mm | 483 | 743 | 994 | 1210 | 1422 | 813 | 914 | 1372 |
| Stainless | 1372mm | 483 | 711 | 949 | 1165 | 1378 | 813 | 914 | 1372 |
| Terrazzo | 914mm | 483 | 743 | 905 | 1121 | 1334 | 533 | 635 | 914 |
| Stainless | 914mm | 483 | 711 | 860 | 1076 | 1289 | 533 | 635 | 914 |

*Juvenile height (terrazzo only): Subtract 102mm from dimensions A through E for juvenile height.



Bowl and Pedestal Assembly (Stainless Steel & Terrazzo) WF2605, WF2608, WF2705, WF2708

P.O. Box 309 • Menomonee Falls, WI 53052-0309 • 1 800 BRADLEY • 262 251 6000 • bradleycorp.com

Length of Tie Pipe Required for Vent Through Washfountain Column

| Type | Pipe Length |
|--|------------------|
| 54" Less Soap Dispenser | 21-1/2" (543mm) |
| 36" Less Soap Dispenser | 18" (457mm) |
| 54" with Soap Dispenser | 30" (762mm) |
| 36" with Soap Dispenser | 26-1/2" (673) |
| 54" Less Soap Dispenser with Towel Dispenser | 55-1/2" (1410mm) |
| 36" Less Soap Dispenser with Towel Dispenser | 52" (1321mm) |
| 54" with Soap Dispenser with Towel Dispenser | 48" (1213mm) |
| 36" with Soap Dispenser with Towel Dispenser | 44-1/2" (1130mm) |
| 54" with Cube Adapter | 32" (813mm) |
| 36" with Cube Adapter | 28-1/2" (724mm) |
| 54" with Cube Adapter with Towel Dispenser | 50" (1270mm) |
| 36" with Cube Adapter with Towel Dispenser | 46-1/2" (1181mm) |
| 54" with Cube Adapter and Soap Dispenser | 40" (1016mm) |
| 36" with Cube Adapter and Soap Dispenser | 36-1/2" (927mm) |



Drain must be connected with 2" schedule 40 welded wrought iron pipe, minimum, to provide lower support for this installation. Vent or support pipe must be of the same material in 1-1/2". For detailed tie pipe information, see 215-1834-26.



Bowl and Pedestal Assembly (Stainless Steel & Terrazzo) WF2605, WF2608, WF2705, WF2708

P.O. Box 309 • Menomonee Falls, WI 53052-0309 • 1 800 BRADLEY • 262 251 6000 • bradleycorp.com

Rough-In Specifications

(mm)

Type A

Off-line vent with
supplies from below

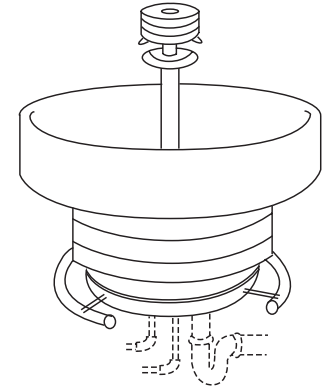
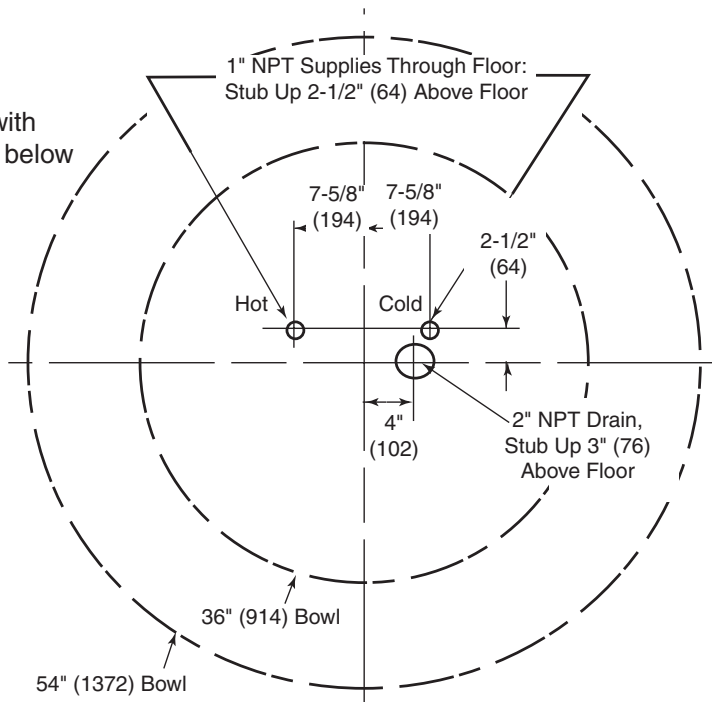

UPC and IPC restricts the vertical distance from the fixture outlet to the trap weir to not more than 24". Check state and local codes for variances.



Some optional equipment shown.

Type B

Centrally rising vent with
supplies from above

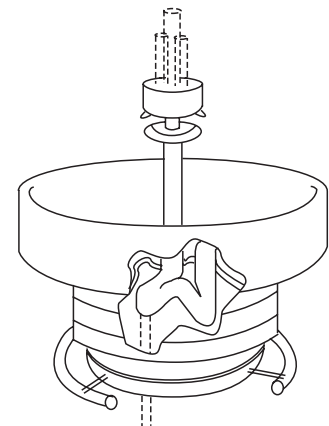
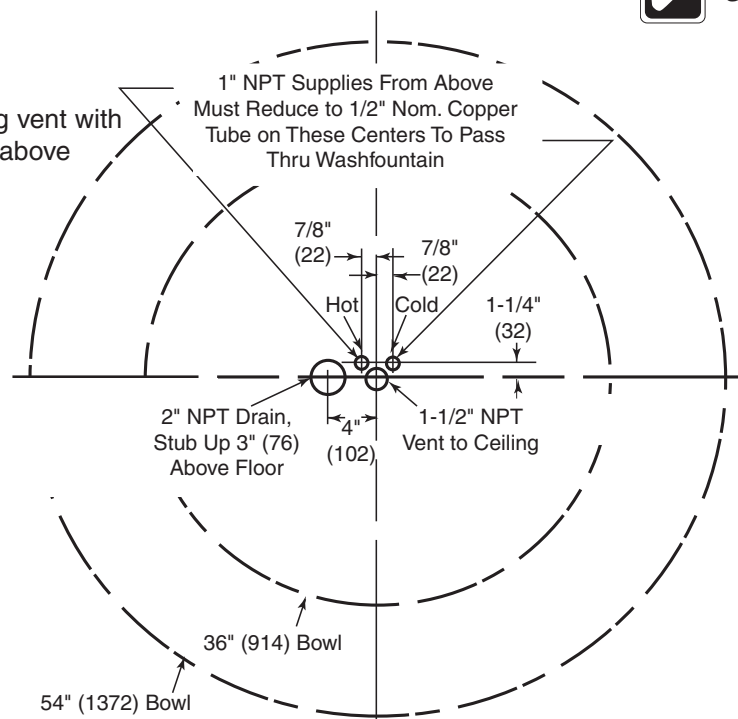

Rough-In Notes

1. All pipes and fittings not furnished by Bradley are shown in broken lines.
2. Supply lines for one to two washfountains should be 1", for three washfountains 1-1/2"; for more than three washfountains, pipe sizes should be increased proportionately.
3. Overhead supplies must be reduced to 1/2" copper tube to pass through support tube.
4. Check valve inlets are 1/2" NPT.



Bowl and Pedestal Assembly (Stainless Steel & Terrazzo) WF2605, WF2608, WF2705, WF2708

P.O. Box 309 • Menomonee Falls, WI 53052-0309 • 1 800 BRADLEY • 262 251 6000 • bradleycorp.com

Rough-In Specifications

(mm)

Type O

Off-line vent with supplies from above

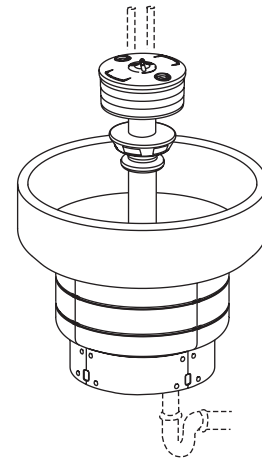
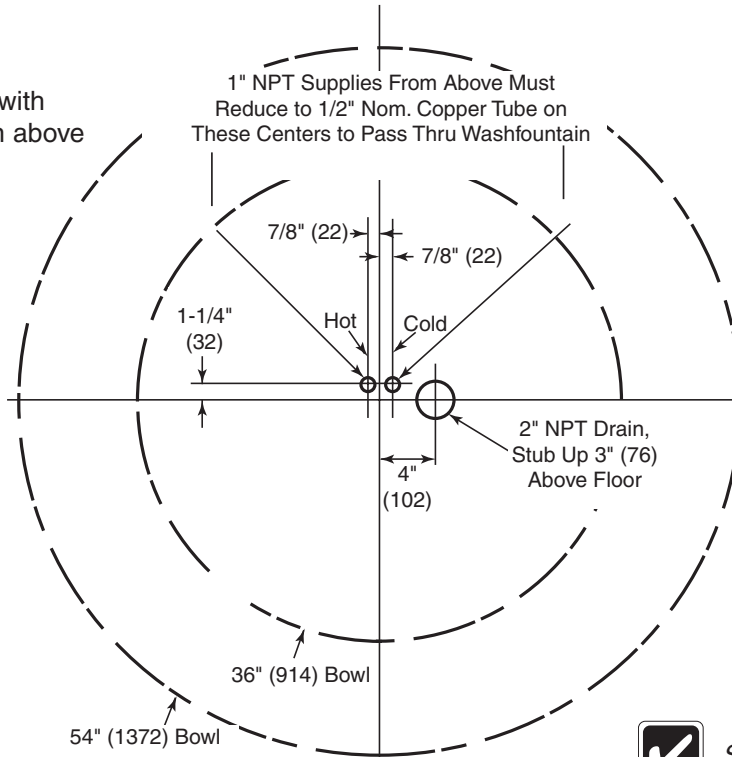

UPC and IPC restricts the vertical distance from the fixture outlet to the trap weir to not more than 24". Check state and local codes for variances.



Some optional equipment shown.

Type H

Centrally rising vent with supplies from below

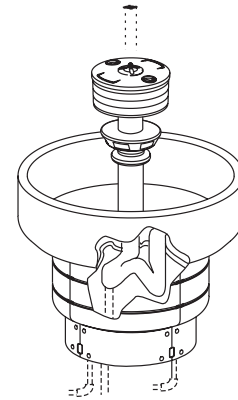
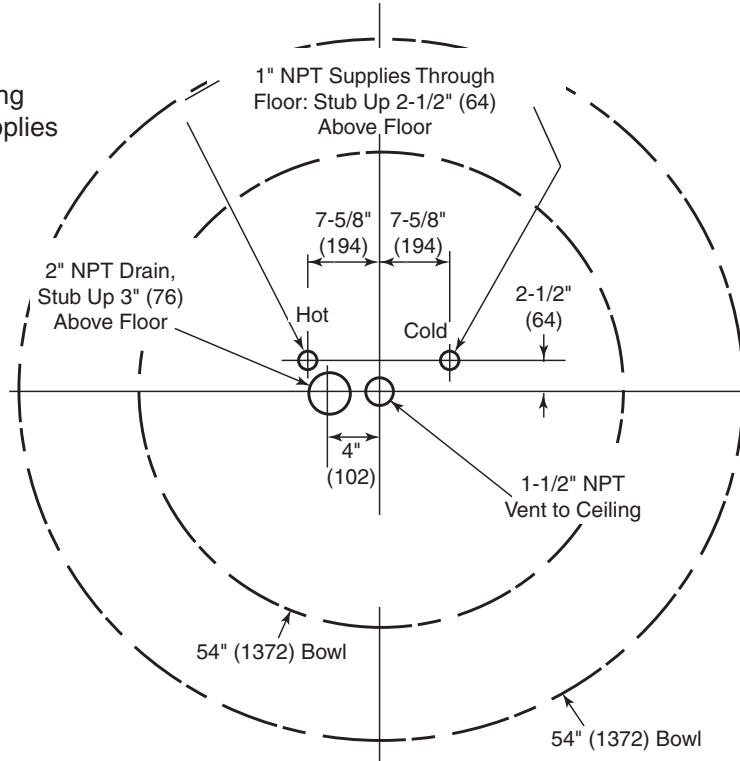

Rough-In Notes

1. All pipes and fittings not furnished by Bradley are shown in broken lines.
2. Supply lines for one to two washfountains should be 1", for three washfountains 1-1/2"; for more than three washfountains, pipe sizes should be increased proportionately.
3. Overhead supplies must be reduced to 1/2" copper tube to pass through support tube.
4. Check valve inlets are 1/2" NPT.



Bowl and Pedestal Assembly (Stainless Steel & Terrazzo) WF2605, WF2608, WF2705, WF2708

P.O. Box 309 • Menomonee Falls, WI 53052-0309 • 1 800 BRADLEY • 262 251 6000 • bradleycorp.com

1 Installing the Drain

A Rough in supply and drain piping as required for your installation.

B Assemble the drain to the dimension shown below for the bowl size you are installing.



All piping shown in dotted lines to be supplied by installer.

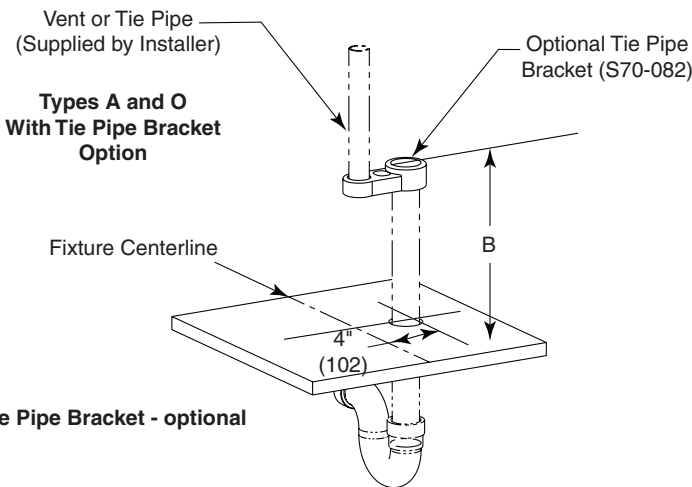
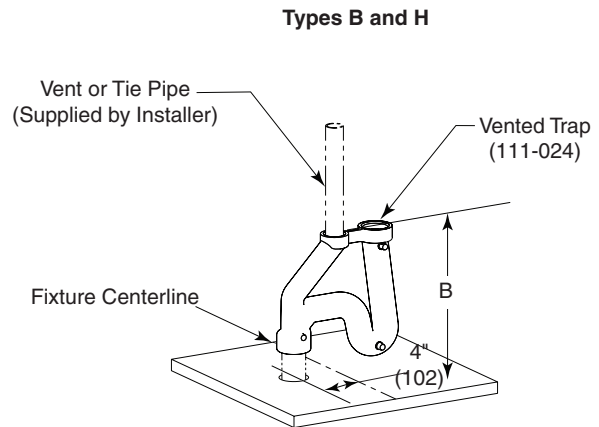
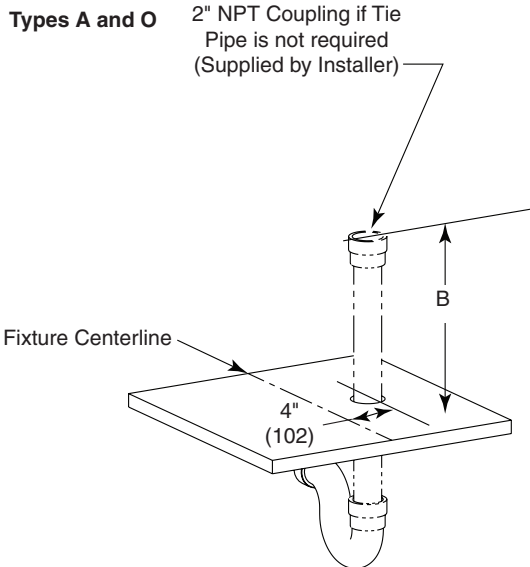

Trap Dimensions (mm)

| Bowl Material | Size | Dim | Standard Height | Juvenile Height |
|-----------------|------|-----|-----------------|-----------------|
| Terrazzo | 36" | B | 18-5/8" (473) | 14-5/8" (371) |
| Terrazzo | 54" | B | 18-5/8" (473) | 14-5/8" (371) |
| Stainless Steel | 36" | B | 17-3/8" (441) | N/A* |
| Stainless Steel | 54" | B | 17" (432) | N/A* |

* Stainless steel is not available in juvenile height.



Bowl and Pedestal Assembly (Stainless Steel & Terrazzo) WF2605, WF2608, WF2705, WF2708

P.O. Box 309 • Menomonee Falls, WI 53052-0309 • 1 800 BRADLEY • 262 251 6000 • bradleycorp.com

2a Assembling the Pedestal (with Foot Control)

A Assemble the legs and scuff base panels with the 5/16" carriage bolts and nuts provided.

B Attach the pedestal frame members with the 5/16" stove bolts and nuts provided.

C Add the foot levers and operating cross to the pedestal assembly.

D Press the foot rail into place with a rolling motion. The joint of the foot rail should be placed in the clevis of one of the foot valves.

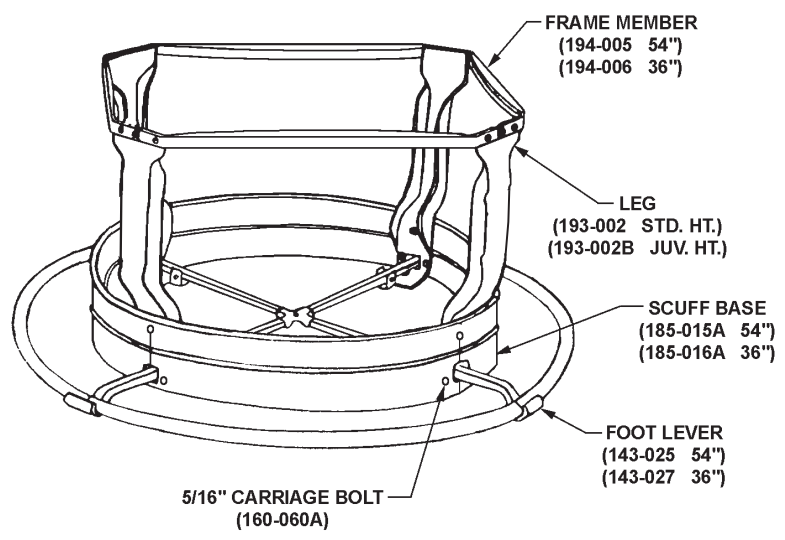
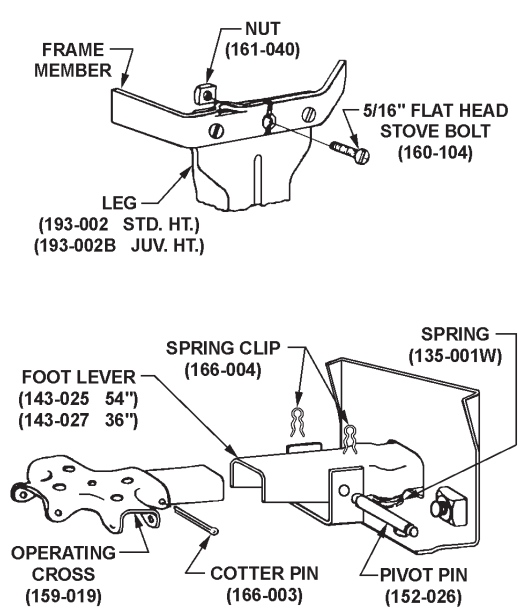

2b Assembling the Pedestal (without Foot Control)

A Assemble the leg and scuff base panels with the 5/16" carriage bolts and nuts provided.

B Attach the pedestal frame members with the 5/16" stove bolts and nuts provided.

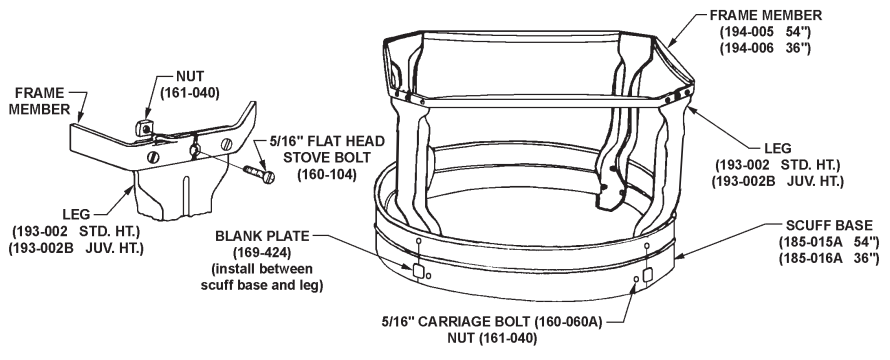



Bowl and Pedestal Assembly (Stainless Steel & Terrazzo) WF2605, WF2608, WF2705, WF2708

P.O. Box 309 • Menomonee Falls, WI 53052-0309 • 1 800 BRADLEY • 262 251 6000 • bradleycorp.com

3 Bowl Assembly and Mounting

NOTICE! The pedestal must be level when secured to floor for proper drainage.

CAUTION! Use suitable lifting equipment to position bowl and pedestal assembly. Handle with care! Failure to do so could result in serious personal injuries.

For Stainless Steel Bowl

A Place the bowl on the pedestal using suitable lifting equipment.

B Fasten the bowl to the pedestal with the four flat head stove bolts provided. Place the bowl clip inside the pedestal leg.

C Position the bowl and pedestal assembly so that the bowl drain is in line with the trap or drain line.

D Screw the drain spud part of the way into the drain to ensure correct alignment.

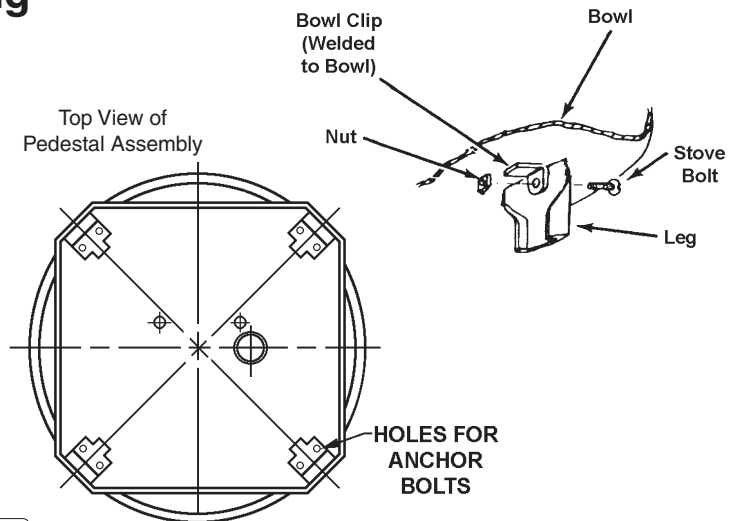

Some optional equipment shown.

E Anchor the pedestal assembly to the floor with suitable anchors/fasteners (supplied by installer).

For Terrazzo Bowl

CAUTION! Bowl surface is smooth. Use suitable lifting equipment to position bowl and pedestal assembly. Handle with care!

A Position the pedestal as shown in pedestal assembly drawing.

B Place the bowl on the pedestal using suitable lifting equipment, making sure that the bowl drain is in line with the trap or drain line.

C Screw the drain spud part of the way into the drain to ensure correct alignment.

D Anchor the pedestal assembly to the floor with suitable anchors/fasteners (supplied by installer).

4 Installing Drain Spud in Bowl

A Secure drain spud with lock nut and washers as shown.

Seal between drain spud and drain hole with plumber's putty (supplied by installer).

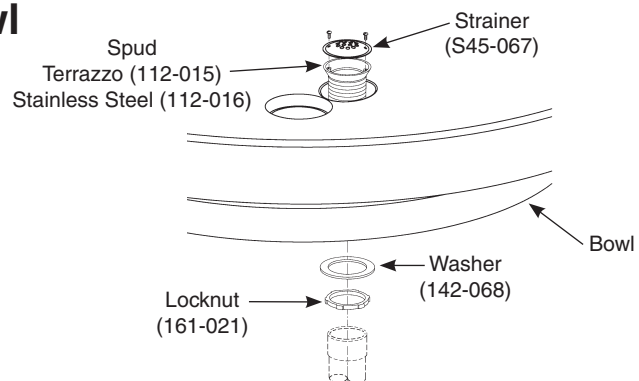



Sprayheads WF2500, WF2600, WF2700, WF2800, WF3200, TDB3100 Series

P.O. Box 309 • Menomonee Falls, WI 53052-0309 • 1 800 BRADLEY • 262 251 6000 • bradleycorp.com

Sectional Sprayhead

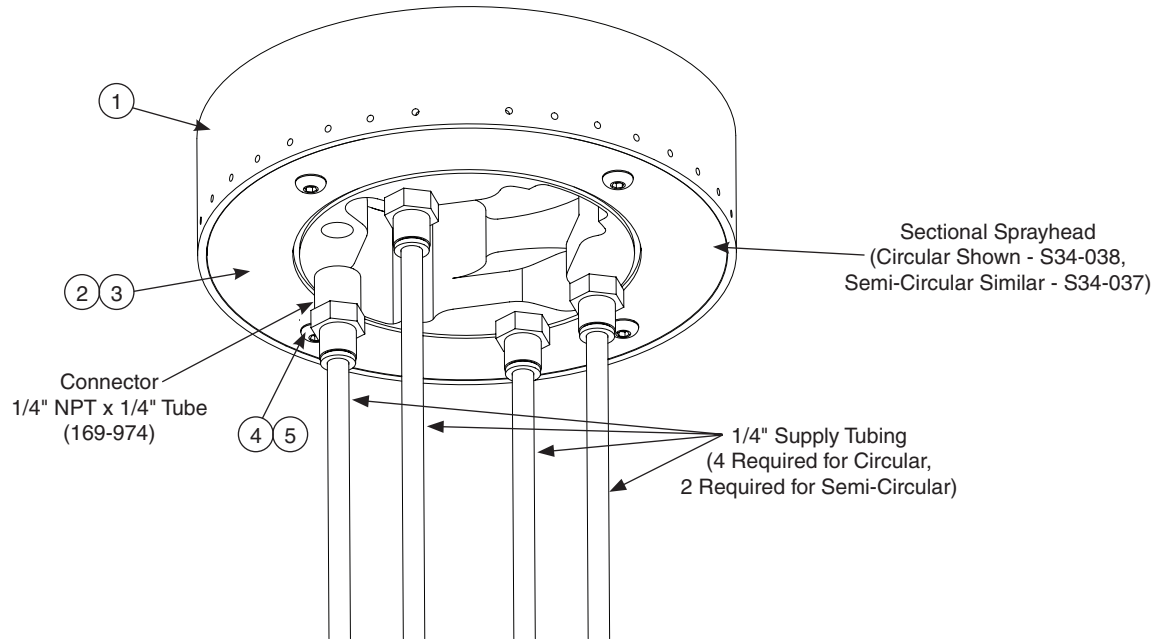

Parts List

| Item | Part No. | Description | Circular | Semi-Circular |
|------|-----------|--|----------|---------------|
| | | | Qty | |
| 1 | 115-080 | Sectional Sprayhead - Plated (Circular) | 1 | |
| 1 | 115-079 | Sectional Sprayhead - Plated (Semi-Circular) | | 1 |
| 2 | 159-115 | Bottom Plate | 1 | 1 |
| 3 | 124-032 | Gasket | 1 | 1 |
| 4 | 160-138 | Screw, 10-24 x 1/2" Button Head | 4 | 4 |
| 5 | 142-002BT | Washer, #10, Split Lock | 4 | 4 |



Non-Sectional Sprayhead



Repair kit does not include sprayhead grommet. Order as a separate item.

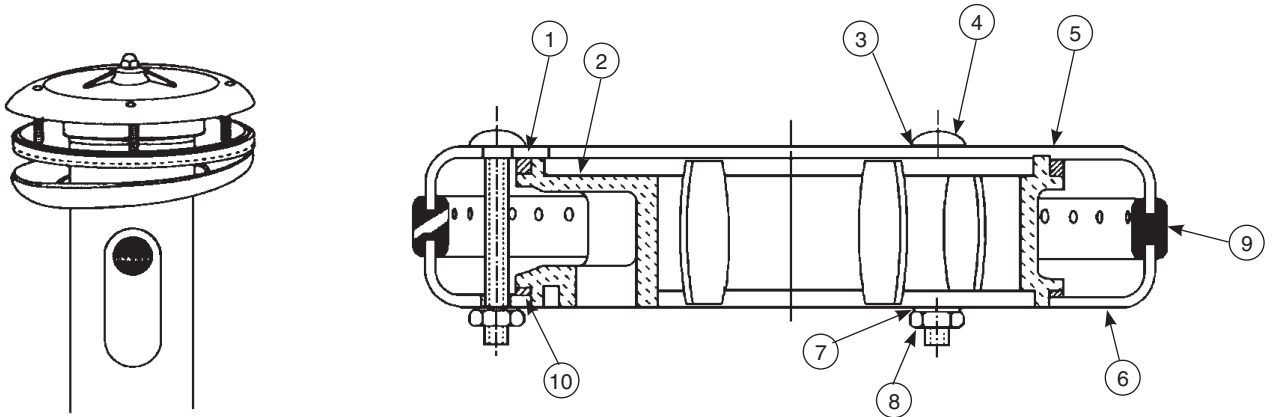

Parts List

| Item | Part No. | Description | Sprayhead Assembly | Repair Kit S45-051 |
|------|-----------|---------------------------------|--------------------|--------------------|
| | | | Qty | |
| 1 | 125-001DE | Neoprene Washer - Top | 1 | 1 |
| 2 | 139-031 | Sprayhead Manifold | 1 | - |
| 3 | 124-001AL | Washer | 3 | 4 |
| 4 | 160-211 | Carriage Bolt | 3 | 4 |
| 5 | 115-061 | Sprayhead Top | 1 | - |
| 6 | 116-008 | Sprayhead Bottom | 1 | - |
| 7 | 124-001AT | Washer | 3 | 4 |
| 8 | 161-025 | Nut | 3 | 4 |
| 9 | 124-020C | Sprayhead Grommet - Circle | 1 | - |
| 9 | 120-020D | Sprayhead Grommet - Semi-Circle | 1 | - |
| 9 | 120-020E | Sprayhead Grommet - Corner | 1 | - |
| 10 | 125-001DF | Neoprene Washer - Bottom | 1 | 1 |



Sprayhead Troubleshooting

| Problem | Cause | Solution |
|---|---|--|
| Water splashes over the rim of the bowl. | Foreign matter has reduced the size of the sprayhead slots, causing greater pressure at the open slots. | Clean the sprayhead: <ol style="list-style-type: none"> 1. Disassemble the sprayhead and dislodge any dirt, lime build-up and foreign debris with a wire brush. 2. Sprayheads with rubber grommet spray rings may be cleaned by rubbing a coin over the grommet. |
| | | Throttle down the volume control (water spray should strike the bowl without splashing outside of the bowl). |
| Water flow diminishes from the sprayhead. | Strainer portion of the stop-strainer-check valve is plugged. | Remove and clean the strainer screen from the stop-strainer-check valve.  <i>The non-sectional sprayhead includes a perforated neoprene spray ring grommet that is self-cleaning. The water pressure flexes the spray holes which slows accumulation of foreign matter and tends to "break loose" any such deposits that may have accumulated.</i> |

Sprayhead Tubing Connections

⚠ WARNING Flush supply lines before making connections.

A Using a sharp razor, cut tubing squarely and remove any burrs. DO NOT pinch or crush end of tubing.

B Loosen nut on fitting. Moisten end of tube and push into fitting until it is firmly seated. Tighten nut to secure tube to fitting (make sure nut is securely tightened).

C If connector leaks, reseal tubing according to above procedure. If leaking persists, replace male connector, or call a Bradley representative for assistance.

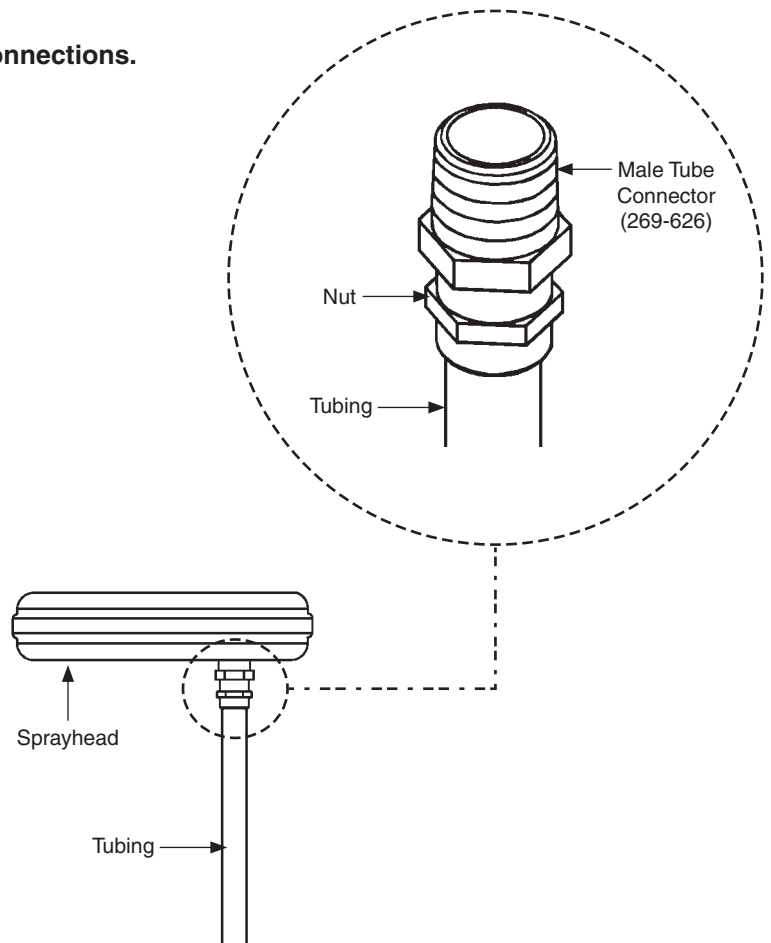



Foot Activation - Non-Sectional Circular Washfountains WF2505, WF2508, WF2605, WF2608, WF2705, WF2708, WF2805, WF2808

P.O. Box 309 • Menomonee Falls, WI 53052-0309 • 1 800 BRADLEY • 262 251 6000 • bradleycorp.com

Supplies Required by Installer

- 1-1/2" vent pipe on types vented through washfountain column
- Pipe sealant and plumber's putty



Supply lines for one or two washfountains should be 1"; for three washfountains 1-1/4"; for more than three washfountains, pipe size should increase proportionally. Vent pipe to be 1-1/2" on models vented through washfountain.

1a Installing Supplies – A and O Units WITH Soap Option

A Install hemmed end (not sharp end) of support tube with gasket onto bowl.

B Using pipe sealant, connect the supply pipe to the sprayhead and place on top of the support tube.

C Place the upper tie bar on top of the sprayhead and join the upper and lower tie rod (the longer threaded rod) with the coupling nut and set screws.

D Insert the tie rod assembly through the hole in the upper tie bar and secure with the lower tie bar, tie rod nut and set screw from below.

E Install the spacer, soap dispenser, dispenser cover and secure with the acorn nut and socket set screw.

1b Installing Supplies – A and O Units WITHOUT Soap Option

A Install hemmed end (not sharp end) of support tube with gasket onto bowl.

B Using pipe sealant, connect the supply pipe to the sprayhead and place on top of the support tube.

C Place the dispenser cover on the sprayhead. Thread the acorn nut onto the lower tie rod, run the tie rod through the dispenser cover and secure from below with the lower tie bar, tie rod nut and socket set screw.



Foot Activation - Non-Sectional Circular Washfountains WF2505, WF2508, WF2605, WF2608, WF2705, WF2708, WF2805, WF2808

P.O. Box 309 • Menomonee Falls, WI 53052-0309 • 1 800 BRADLEY • 262 251 6000 • bradleycorp.com



Some optional equipment shown.

Type "O" Drain Supplies from Above

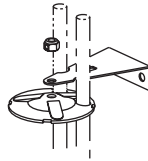

Type "A" Drain

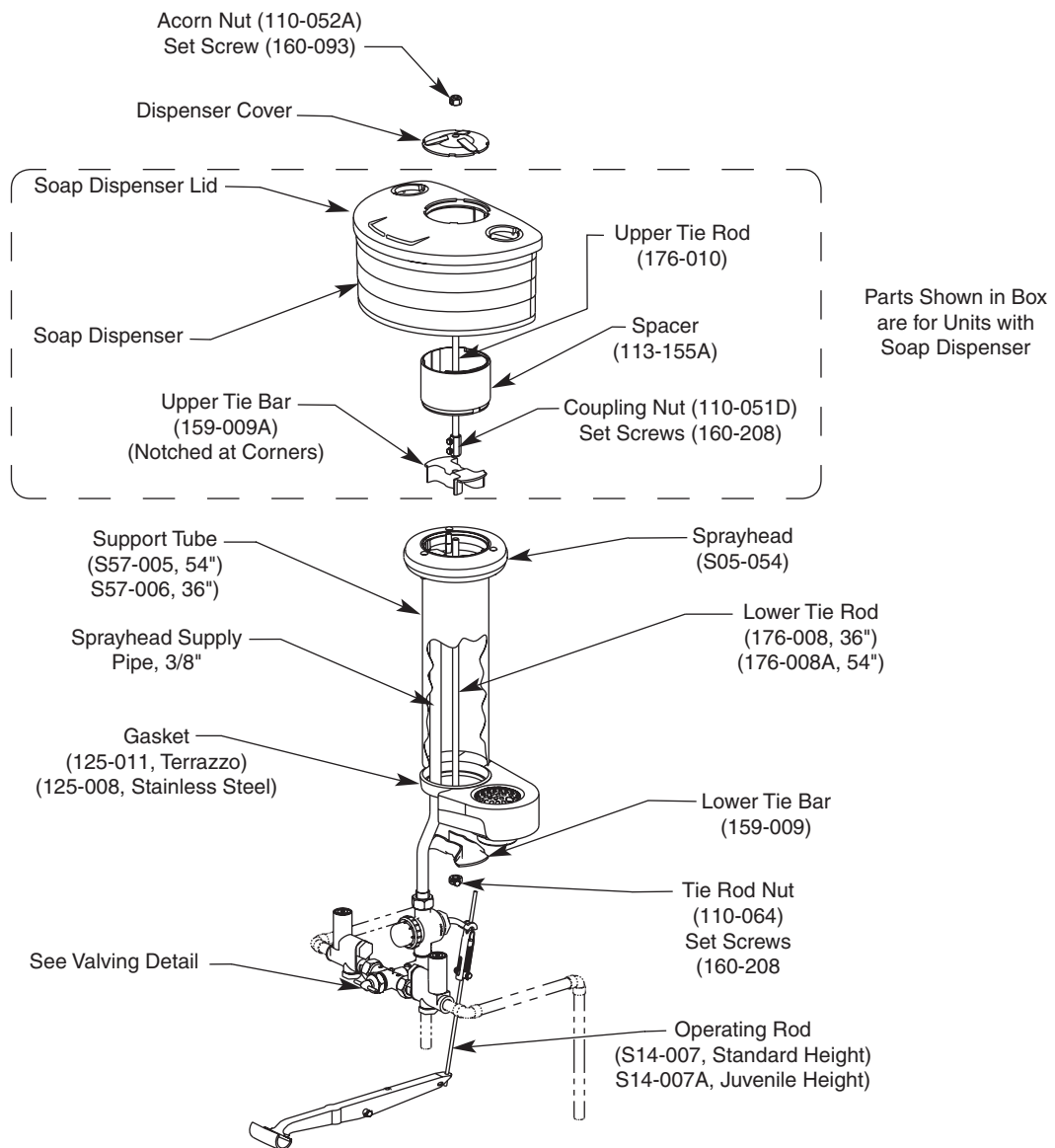



Foot Activation - Non-Sectional Circular Washfountains WF2505, WF2508, WF2605, WF2608, WF2705, WF2708, WF2805, WF2808

P.O. Box 309 • Menomonee Falls, WI 53052-0309 • 1 800 BRADLEY • 262 251 6000 • bradleycorp.com

1c Installing Supplies – B and H Units WITH Soap Option

A Install hemmed end (not sharp end) of support tube with gasket onto bowl.

B Using pipe sealant, connect the supply pipe to the sprayhead and place on top of the support tube.

C Insert the 1-1/2" vent pipe (supplied by installer) through the soap dispenser with the spacer (if provided), sprayhead and support tube. Connect to vented trap (provided).

D Slide the tie bar over the 1-1/2" vent pipe 1/2" below the top of the soap dispenser and secure with the set screws.

E Slide the dispenser cover over the 1-1/2" vent pipe and secure with the two screws (included) to the tie bar.

F Connect the vent pipe to the vent through the ceiling with the pipe union.

1d Installing Supplies – B and H Units WITHOUT Soap Option

A Install hemmed end (not sharp end) of support tube with gasket onto bowl.

B Using pipe sealant, connect the supply pipe to the sprayhead and place on top of the support tube.

C Insert the 1-1/2" vent pipe (supplied by installer) through the sprayhead and support tube. Connect to vented trap (provided).

D Slide the tie bar over the 1-1/2" vent pipe, 1/2" below the top of the sprayhead and secure with the set screws.

E Secure the dispenser cover over the 1-1/2" vent pipe and secure with the two screws included with the tie bar.

F Connect the vent pipe to the vent through the ceiling with the pipe union.



Foot Activation - Non-Sectional Circular Washfountains WF2505, WF2508, WF2605, WF2608, WF2705, WF2708, WF2805, WF2808

P.O. Box 309 • Menomonee Falls, WI 53052-0309 • 1 800 BRADLEY • 262 251 6000 • bradleycorp.com



Some optional equipment shown.

Type "H" Drain Supplies from Below

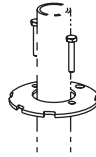

Type "B" Drain

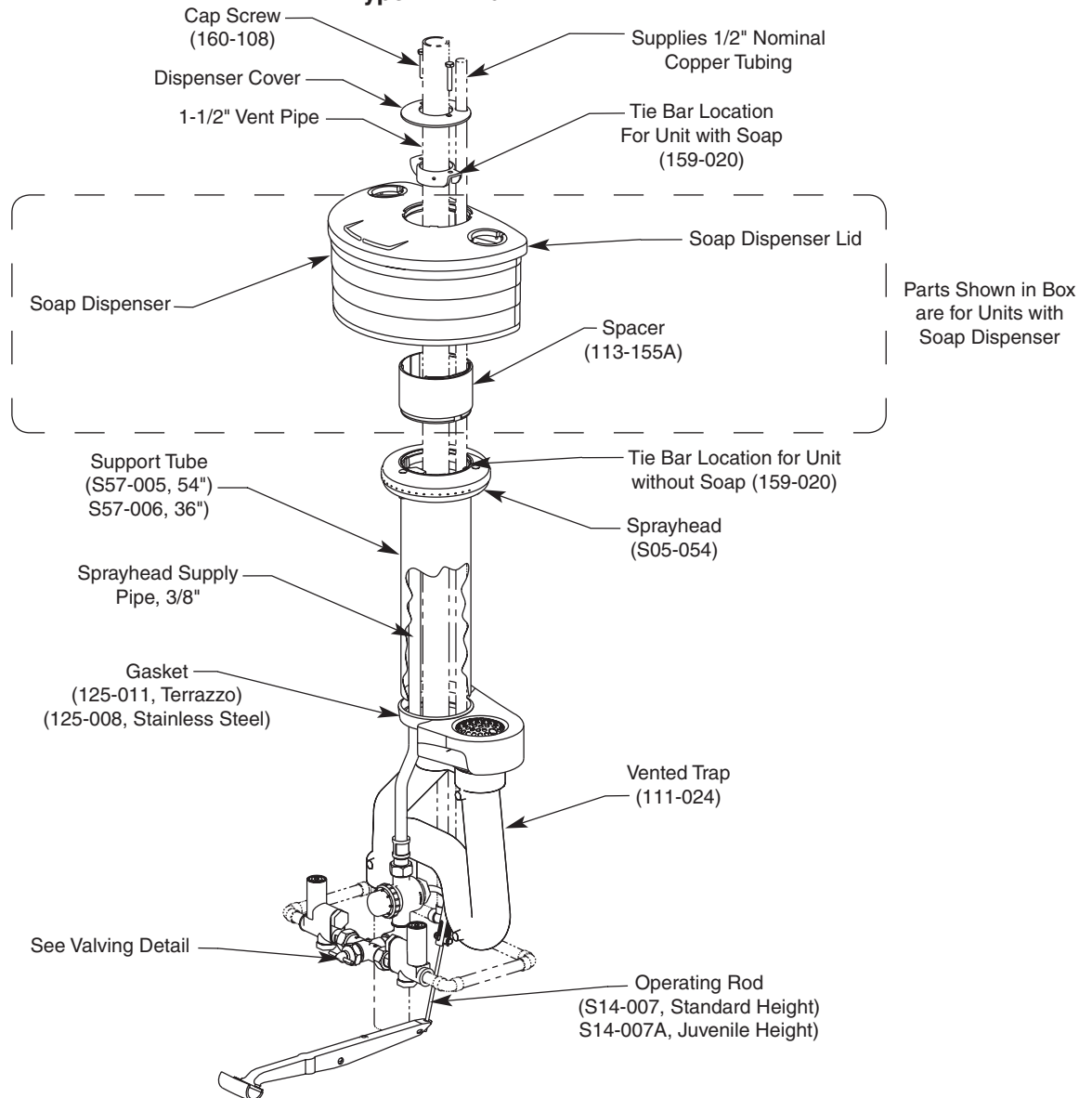



Foot Activation - Non-Sectional Circular Washfountains WF2505, WF2508, WF2605, WF2608, WF2705, WF2708, WF2805, WF2808

P.O. Box 309 • Menomonee Falls, WI 53052-0309 • 1 800 BRADLEY • 262 251 6000 • bradleycorp.com

2 Installing the Valve Assembly



Flush supply lines before making connections.

A

Connect the stop-strainer-check valves, mixing valve, volume control valve and foot valve as shown.

B

For overhead supply lines, install 1/2" nominal copper supply tubing by passing the lines through the holes in the dispenser cover and then down through the support tube.

C

Install the valving assembly using suitable fittings to the supplies as shown at the approximate height indicated in table below.

D

Slide the tailpiece nut over the tailpiece and connect the tailpiece to the supply pipe (or to the nipple/coupling for B or H drain).



See 215-1834-22 for further details on valving components.

Distance to Finished Floor

| Model | Type A | Type B | Type H | Type O |
|-----------------|----------------|-----------------|-----------------|----------------|
| Standard Height | 9" (229mm) | 6-3/16" (157mm) | 6-3/16" (157mm) | 9" (229mm) |
| Juvenile Height | 5-1/4" (133mm) | 3-7/16" (87mm) | 3-7/16" (87mm) | 5-1/4" (133mm) |

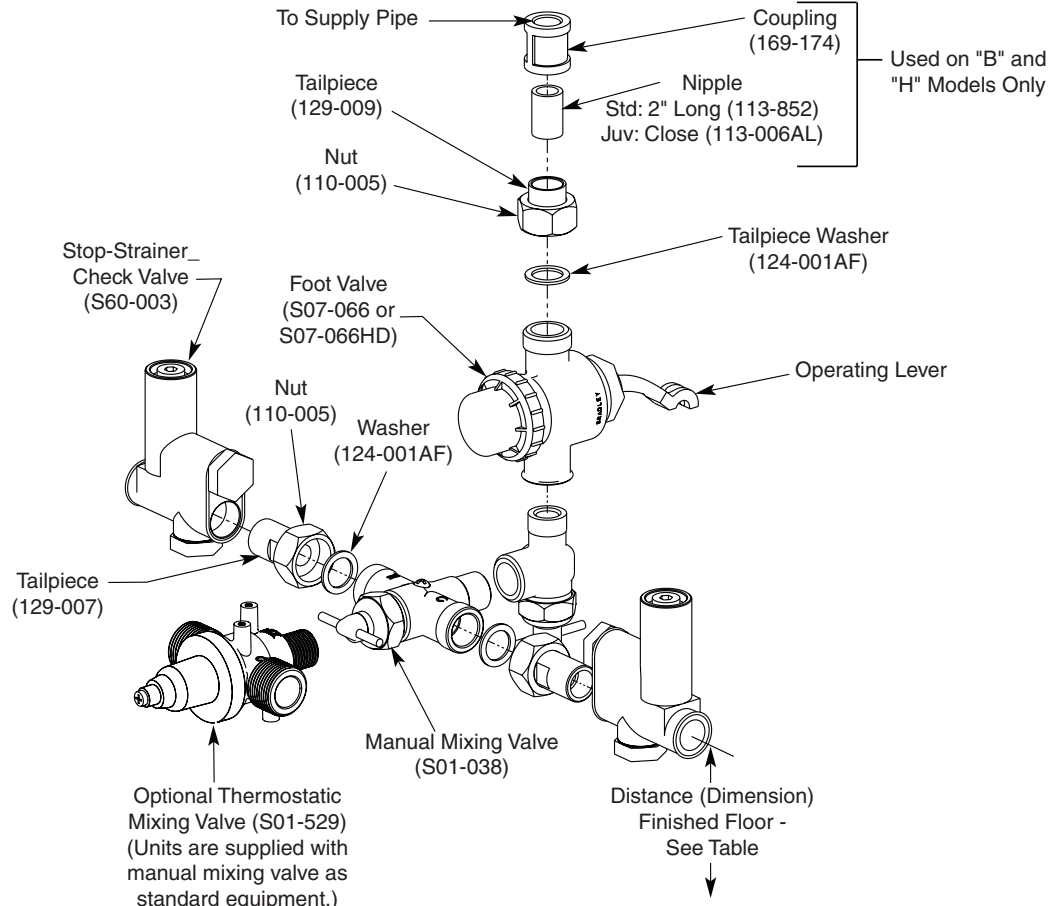



Foot Activation - Non-Sectional Circular Washfountains WF2505, WF2508, WF2605, WF2608, WF2705, WF2708, WF2805, WF2808

P.O. Box 309 • Menomonee Falls, WI 53052-0309 • 1 800 BRADLEY • 262 251 6000 • bradleycorp.com

3 Installing the Operating Rod

A Insert the operating rod in the operating rod lever and then into the foot lever or operating cross (if equipped).



For normal operation, use the operating rod as shipped. The spring loaded cartridge should be adjusted so there is no play in the operating lever. Care must be taken to ensure that a snug fit is achieved without activating the foot valve or water will leak from the sprayhead.

B

When movement of the operating rod is insufficient to open the foot valve, disassemble the rod and remove the spacer and override spring. Reassembly the operating rod as shown. Reinstall and adjust so that the foot valve is completely open when the foot lever is fully depressed. This prevents damage to the foot valve due to the absence of the override spring.

C

Turn supplies on and activate the sprayhead. Check piping installation for leaks.

D

Clean the sprayhead if necessary. Adjust the volume control valve, if necessary, to control the flow of water.

E

Install pedestal panels to complete installation.

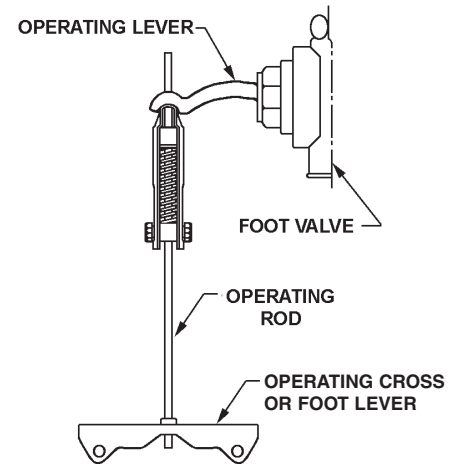

STANDARD OPERATING ROD WITH
SPRING-LOADED CARTRIDGE
(S14-007 STD. HT.)
(S14-007A JUV. HT.)

