Adjustment Instructions & Parts Breakdown for the HFP Valve S90-321, S90-322, S90-323, S90-324, & S90-325

HFP Valve Adjustment Instructions

Steps

Refer to the figure and parts breakdown list on page 2.

1. Turn of the water supply to the HFP valve.
2. Insert a 3/16" hex wrench into the broached/hex end of the lifting stem (Item 8).
3. Holding the lifting stem (Item 8) in place, back off the stop nut (Item 21).
4. Then back off the bar nut (Item 19) by turning the handle assembly (Item 1).
5. Tighten the bonnet nut (Item 3).
6. Run the bar nut (Item 19) down by turning the handle assembly (Item 1) until the bar nut sits on the stainless steel washer (Item 2). Then back off the bar nut approximately 1/4" turn until the handle assembly returns to its original position.
7. Tighten the stop nut (Item 21) down on the bar nut (Item 19).
8. Open water supply line to the unit.

Trouble-Shooting Instructions for Valve Leakage

Through normal, daily usage the valve may begin to leak. If this leaking occurs do the following:
(Refer to the figure and parts breakdown list on page 2.)

1. Turn off the water supply to the HFP valve.
2. Loosen the bonnet nut (Item 3) only. DO NOT loosen the stop nut (Item 21) or the bar nut (Item 19).
3. Remove the bonnet nut (Item 3) and handle assembly (Item 1) to expose the lifting stem (Item 8).
4. Check the condition of the faucet washer (Item 14) at the end of the lifting stem (Item 8). If the faucet washer is scored or worn replace it with a new one.
5. If the faucet washer (Item 14) is undamaged, or after replacing the faucet washer, re-insert the lifting stem (Item 8) into the casing pipe (Item 7). Care must be taken to make sure the guide (Item 10) does not get hung-up as the lifting stem is lowered.
6. Hand tighten the bonnet nut (Item 3).
7. Repeat Steps 2 - 8 of the adjustment procedure given in the HFP Valve Adjustment Instructions above.

HFP Valve Parts Breakdown

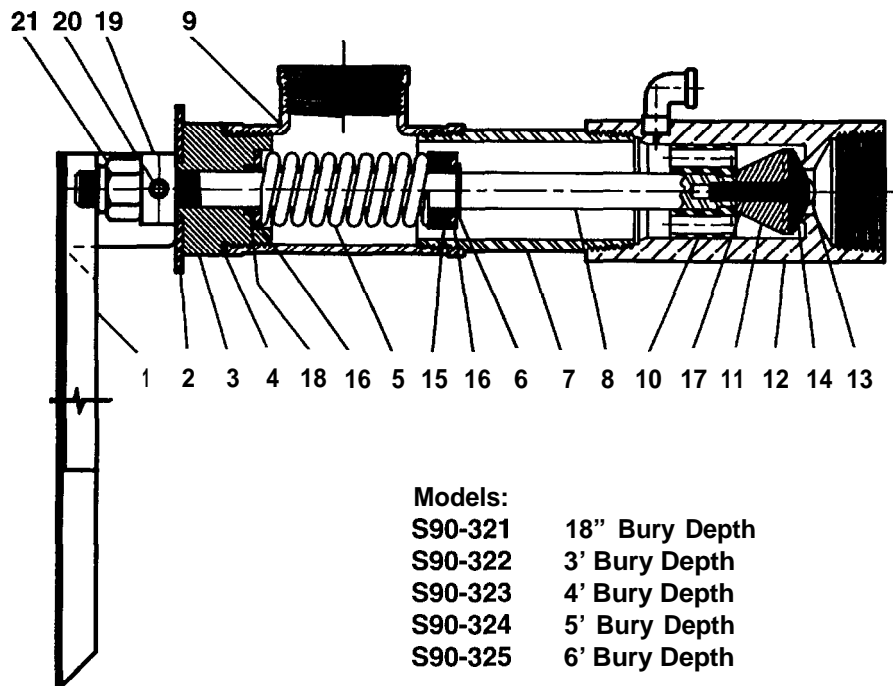

Models:
S90-321 18" Bury Depth
S90-322 3' Bury Depth
S90-323 4' Bury Depth
S90-324 5' Bury Depth
S90-325 6' Bury Depth

ITEM	PART NO.	QTY.	DESCRIPTION	ITEM	PART NO.	QTY.	DESCRIPTION
1	S08-040	1	HANDLE ASSY.	8	120-128E	1	LIFTING STEM (6' BURY DEPTH)
2	142-002BB	1	STN. STL. WASHER	9	269-237B	1	TEE
3	110-218	1	BONNET NUT	10	145-072	1	GUIDE
4	124-001BS	1	GASKET	11	132-041	1	RETAINER
5	135-001AP	1	SPRING	12	S73-057	1	VALVE BODY ASSY.
6	132-012	1	RETAINING RING	13	160-138	1	MACHINE SCREW
7	113-868	1	CASING PIPE (18" BURY DEPTH)	14	169-920	1	FAUCET WASHER
7	113-869	1	CASING PIPE (3' BURY DEPTH)	15	182-061	1	SPACER
7	113-870	1	CASING PIPE (4' BURY DEPTH)	16	142-002CC	3	WASHER
7	113-871	1	CASING PIPE (5' BURY DEPTH)	17	160-251	1	SCREW STUD
7	113-872	1	CASING PIPE (6' BURY DEPTH)	18	125-001CD	1	O-RING
8	120-128A	1	LIFTING STEM (18" BURY DEPTH)	19	110-219	1	BAR NUT
8	120-128B	1	LIFTING STEM (3' BURY DEPTH)	20	165-038	2	ROLL PIN
8	120-128C	1	LIFTING STEM (4' BURY DEPTH)	21	161-073	1	STOP NUT
8	120-128D	1	LIFTING STEM (5' BURY DEPTH)				