

Installation

S19-270HC (Eyewash)

S19-270JC (Eye/Face Wash)

Cabinet-Mounted Swing-Down Eyewash and Eye/Face Wash

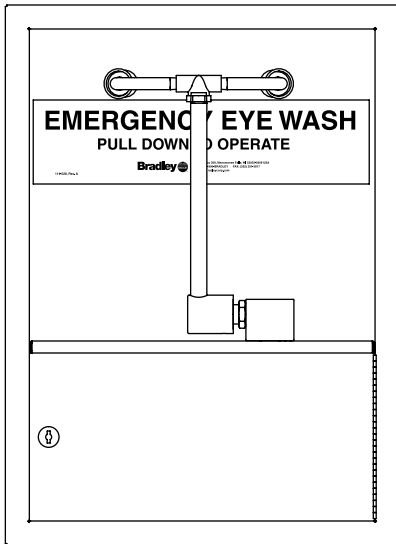

S19-270HC

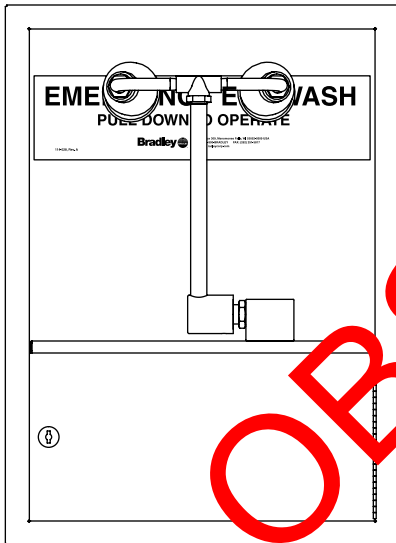

S19-270JC

Table of Contents

Pre-Installation Information	2
Installation	2
S19-270HC Dimensions	3
S19-270JC Dimensions	3
S19-270HC Assembly of Components and Parts List	4
S19-270JC Assembly of Components and Parts List	5

IMPORTANT



Read this installation manual completely to ensure proper installation, then file it with the owner or maintenance department. Compliance and conformity to drain requirements and other local codes and ordinances is the responsibility of the installer.



Separate parts from packaging and make sure all parts are accounted for before discarding any packaging material. If any parts are missing, do not begin installation until you obtain the missing parts.

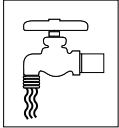

Flush the water supply lines before beginning installation and after installation is complete. Test the unit for leaks and adequate water flow. Main water supply to the eyewash should be "ON" at all times. Provisions shall be made to prevent unauthorized shutoff.

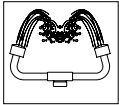

The ANSI Z358.1 standard requires an uninterrupted supply of flushing fluid. Bradley plumbed emergency fixtures require a minimum of 30 PSI (0.21 MPa) flowing pressure. Flushing fluid should be tepid per ANSI Z358.1.

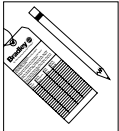

The inspection and testing results of this equipment should be recorded weekly to verify proper operation. This equipment should be inspected annually to ensure compliance with ANSI Z358.1.



Workers who may come in contact with potentially hazardous materials should be trained regarding the placement and proper operation of emergency equipment per ANSI Z358.1.



For questions regarding the operation or installation of this product, visit bradleycorp.com or call 800.BRADLEY (800.272.3539).

Product warranties may also be found under "Products" at bradleycorp.com.

Installation

NOTICE! Avoid cleaners containing organic solvents, alcohols, and hydrocarbons. Rinse with water after cleaning.

Supplies Required:

- ½" NPT water supply inlet on unit
- Bolts for cabinet mounting
- Pipe sealant
- Sign-mounting hardware



Local codes may require the installation of a backflow prevention valve to complete proper installation. Compliance with local codes is the responsibility of the installer. Valve must be tested annually to verify that it is functioning properly. Backflow prevention valves are not included with the fixture and may be supplied by the contractor or purchased from Bradley Corporation.

Step 1: Rough-In

1. Rough in the wall opening.
2. Rough in the ½" NPT water supply (refer to page 3).
3. Position the unit in the wall opening. Mount the unit to the wall with four bolts (supplied by installer).
4. With the cabinet door open, connect the water supply using the coupling nut and combination tailpiece (refer to page 4).
5. Mount the safety sign to the wall with appropriate hardware supplied by the installer.

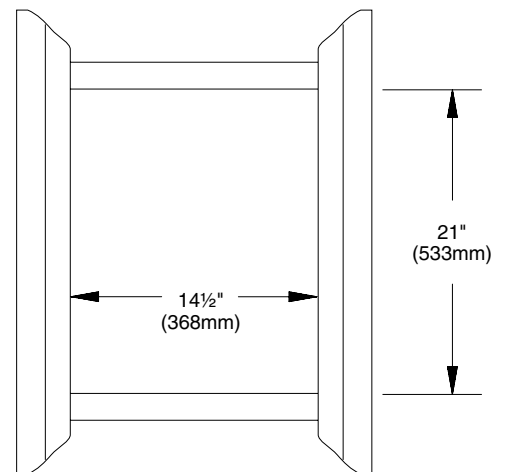

S19-270HC Dimensions

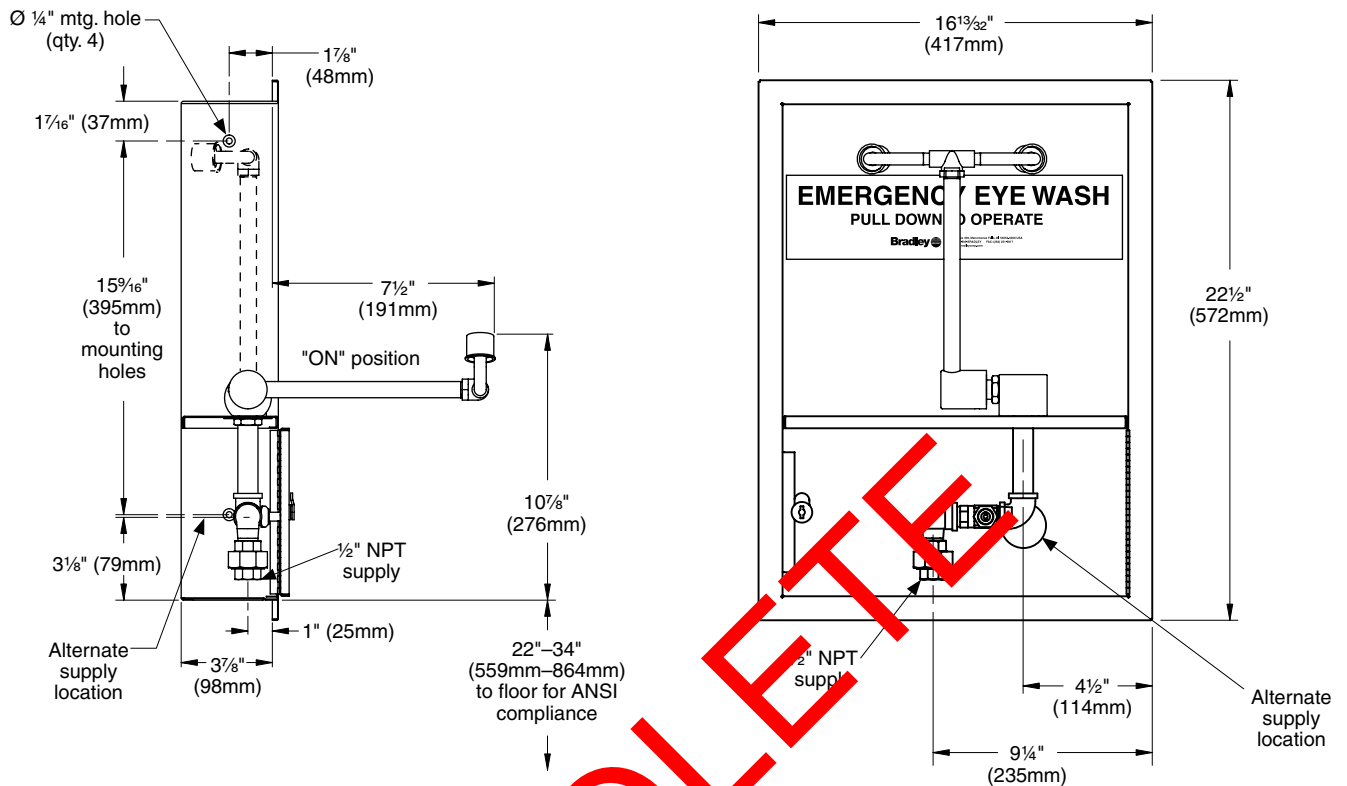

S19-270JC Dimensions

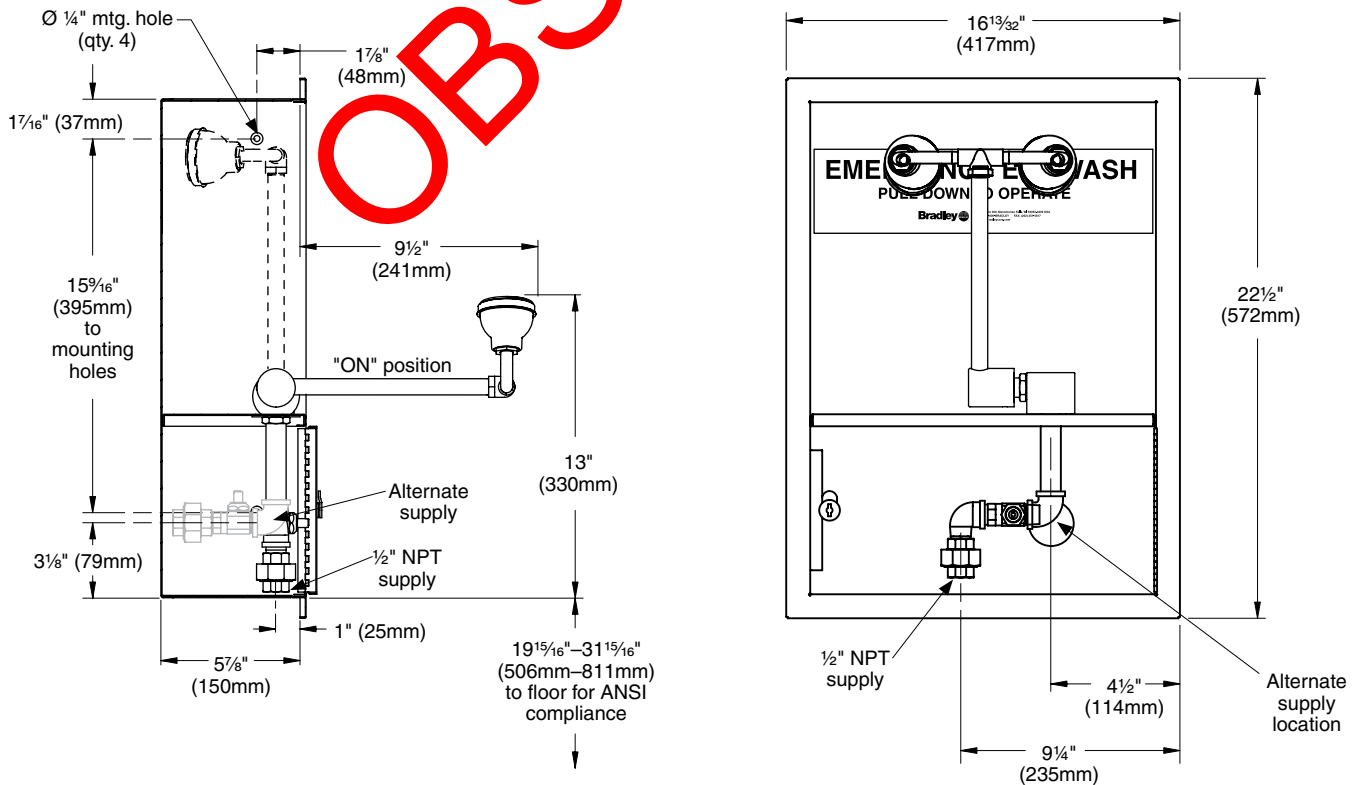

Assembly of Components and Parts List — S19-270HC

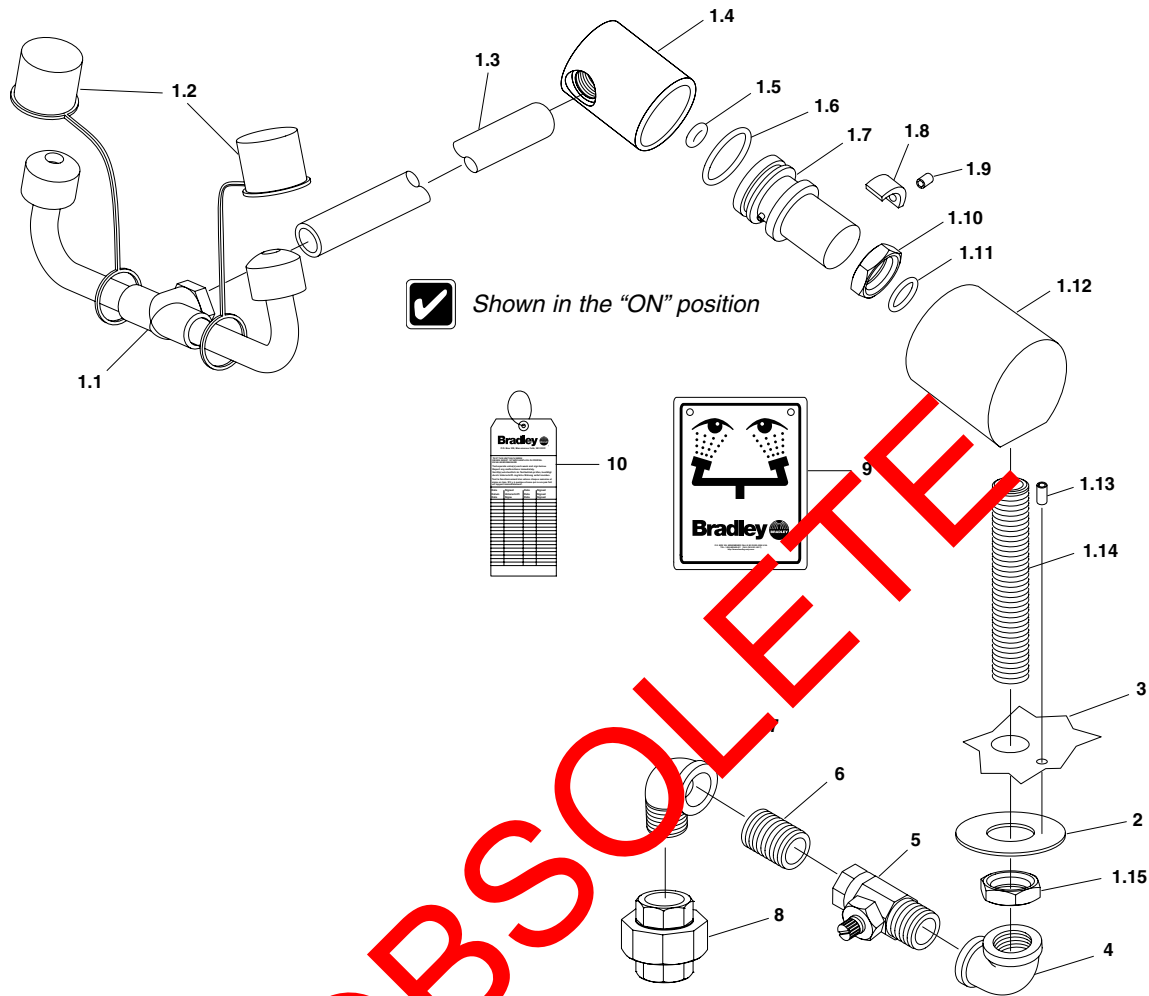

Item	Part No.	Qty.	Description	Item	Part No.	Qty.	Description
1	S39-679A	1	Swing-Down Sub-Assembly	1.13	160-428	1	Screw, Set
1.1	S05-092	1	Eyewash Assembly	1.14	113-1058	1	Shank
1.2	107-371	2	Tethered Dust Cover	1.15	110-115	1	Nut, Hex
1.3	113-1075	1	Pipe, 9½" (Plated)	2	142-045A	1	Spacer
1.4	118-288	1	Valve Body (Plated)	3	S39-160	1	Cabinet Assembly
1.5	125-135	1	O-Ring	4	169-364	1	90° Elbow
1.6	125-120	1	O-Ring	5	S27-110	1	Stop Valve
1.7	S39-598	1	Actuator Sub-Assembly, Valve	6	113-006DH	1	Nipple, Close
1.8	192-016	1	Insert, Direction (Plated)	7	169-639	1	90° Street Elbow
1.9	160-413	1	Screw, Set	8	169-348	1	Union
1.10	110-115A	1	Nut, Hex (Plated)	9	114-051	1	Safety Sign
1.11	125-001DA	1	O-Ring	10	204-421	1	Emergency Inspection Tag
1.12	131-082	1	Base				

Assembly of Components and Parts List — S19-270JC

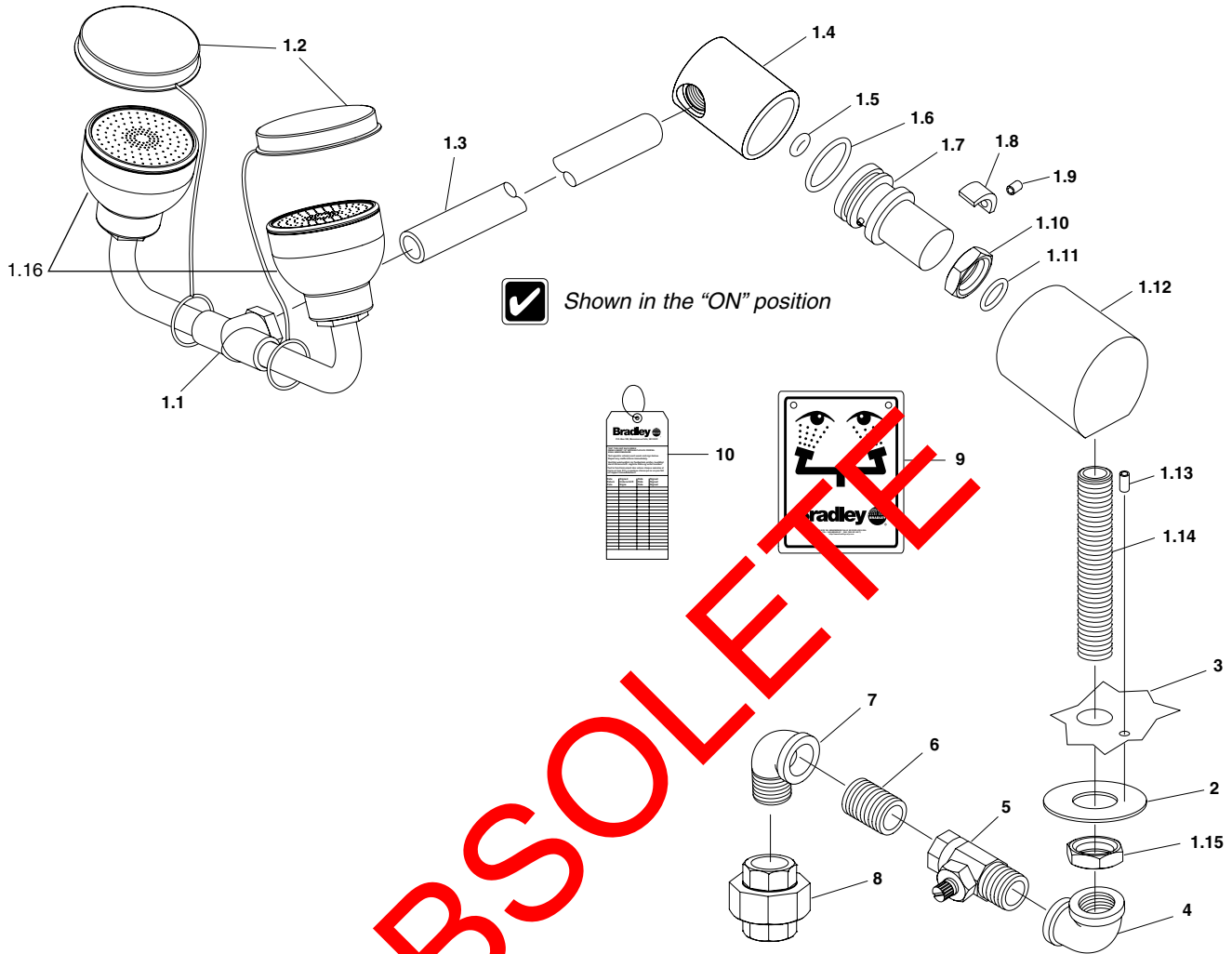

Shown in the "ON" position

OBSOLETE

Item	Part No.	Qty.	Description
1	S39-680A	1	Swing-Down Sub-Assembly
1.1	S05-162	1	Eye/Face Wash Yoke Sub-Assembly
1.2	S53-063	2	Tethered Dust Cover
1.3	113-1075	1	Pipe, 9½" (Plated)
1.4	118-288	1	Valve Body (Plated)
1.5	125-135	1	O-Ring
1.6	125-120	1	O-Ring
1.7	S39-598	1	Actuator Sub-Assembly, Valve
1.8	192-016	1	Insert, Direction (Plated)
1.9	160-413	1	Screw, Set
1.10	110-115A	1	Nut, Hex (Plated)
1.11	125-001DA	1	O-Ring
1.12	131-082	1	Base

Item	Part No.	Qty.	Description
1.13	160-428	1	Screw, Set
1.14	113-1058	1	Shank
1.15	110-115	1	Nut, Hex
1.16	S05-158	1	Eye/Face Wash Assembly
2	142-045A	1	Spacer
3	S39-160	1	Cabinet Assembly
4	169-364	1	90° Elbow
5	S27-110	1	Stop Valve
6	113-006DH	1	Nipple, Close
7	169-639	1	90° Street Elbow
8	169-348	1	Union
9	114-051	1	Safety Sign
10	204-421	1	Emergency Inspection Tag